



JOINT HIGHWAY RESEARCH PROJECT

JHRP-76-2

A COMPREHENSIVE PAVEMENT
EVALUATION SYSTEM: APPLICATION
TO CRCP

E. J. Yoder
A. Faiz
D. G. Shurig

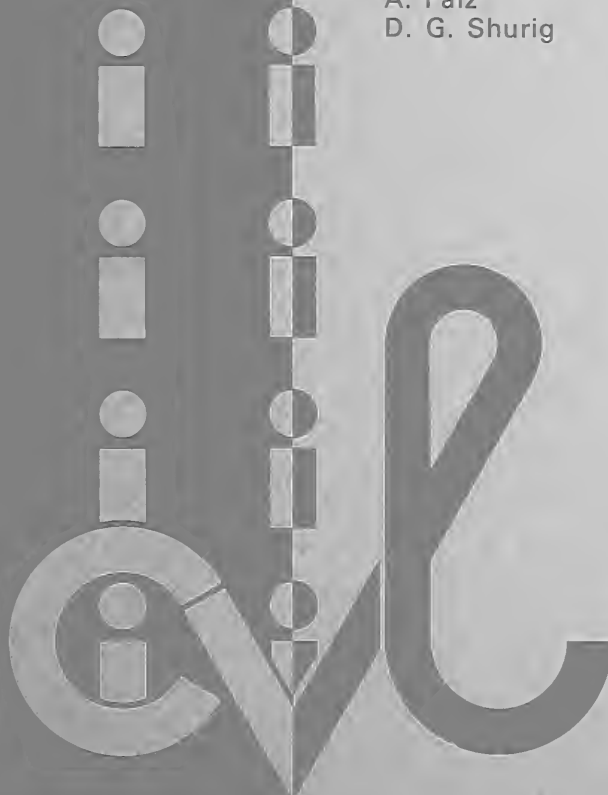

PURDUE UNIVERSITY

INDIANA STATE

HIGHWAY COMMISSION

Technical Paper

A COMPREHENSIVE PAVEMENT EVALUATION SYSTEM:
APPLICATION TO CRCP

TO: J. F. McLaughlin, Director
Joint Highway Research Project

January 13, 1976

FROM: H. L. Michael, Associate Director
Joint Highway Research Project

Project: C-36-52J
File: 6-20-6

Attached is a Technical Paper titled "A Comprehensive Pavement Evaluation System: Application to CRCP", which will be presented at the January, 1976 meeting of the Transportation Research Board. It has been authored by Messrs. E. J. Yoder, Asif Faiz and D. G. Shurig. The paper is a summary of some of the developments resulting from the JHRP research study titled "Evaluation of CRC Pavements in Indiana" in which the three authors were investigators. The material has been previously presented to the Board in Interim and Final Reports on this study.

The paper may be published by the TRB. It is requested that approval to offer the paper for such publication be granted.

Respectfully submitted,



Harold L. Michael
Associate Director

HLM:bjp

cc: W. L. Dolch	G. A. Leonards	M. B. Scott
R. L. Eskew	C. W. Lovell	K. C. Sinha
G. D. Gibson	R. F. Marsh	L. E. Wood
W. H. Goetz	R. D. Miles	E. J. Yoder
M. J. Gutzwiller	P. L. Owens	S. R. Yoder
G. K. Hallock	G. T. Satterly	
D. E. Hancher	C. F. Scholer	
M. L. Hayes		

NOT FOR PUBLICATION

Technical Paper

A COMPREHENSIVE PAVEMENT EVALUATION SYSTEM:
APPLICATION TO CRCP

by

Eldon J. Yoder

Professor of Highway Engineering

Asif Faiz

International Bank for Reconstruction and Development

Donald G. Shurig

Associate Professor of Civil Engineering

Joint Highway Research Project

Purdue University

and the

Indiana State Highway Commission

Presented at the

55th Annual Meeting

of the Transportation Research Board

January, 1976

NOT FOR PUBLICATION

ABSTRACT

Since 1972, a continuing study of the performance of CRC pavements has been in progress at the Joint Highway Research Project, Purdue University. The objective of the research program is to evaluate and recommend design and construction techniques that would help to improve the performance of CRCP.

The evaluation study consisted of the following sequential steps:

1. Reconnaissance survey
2. Pavement condition survey
3. Detailed field evaluation survey

This approach permitted considerable flexibility in the conduct of the research. Each sequential step in the research was designed on the basis of the results of the previous step. As a result, considerable economy in the research effort was obtained.

The CRC pavement condition survey was conducted on a state-wide basis wherein every CRCP construction contract in Indiana was included in the survey. A total of 89 survey sections, each 5000 ft in length, were used. These were obtained by random sampling, stratified over the following factors: construction contract, method of paving, method of steel placement, method of steel fabrication (type of reinforcement), subbase type and subgrade parent material.

The results of the CRC pavement condition surveys indicated that subbase type, methods of steel placement and steel fabrica-

Digitized by the Internet Archive
in 2011 with funding from
LYRASIS members and Sloan Foundation; Indiana Department of Transportation

tion, concrete slump, and age of the pavement since opened to traffic were significant contributors to pavement performance.

Based on these results, a field investigation of CRC pavements was conducted. The purpose of this phase of the research was to evaluate the parameters that were found to contribute significantly to CRCP performance in the condition survey. This was accomplished by conducting a field testing program on in-service CRC pavement sections.

For this part of the study, the length of test sections was taken as 1000 ft. Normally these test sections were required to lie within the condition survey sections so that a wide inference space, in terms of the independent explanatory variables, could be maintained.

All the test sections were located on Interstate Highways in order to obtain a homogeneous set of test sections in terms of thickness, 9-inches (22.9 cm) and traffic intensity. Where possible, a good location was compared with a failed location within each test section.

This paper describes:

1. Concepts underlying the comprehensive evaluation system.
2. Method of setting up the condition survey.
3. Method of making the evaluation survey.
4. Use of the results of the surveys for establishing a maintenance research project for CRCP.

Some of the significant findings of the study are included. The results of the study show that failures in CRCP are a function

of a number of interacting variables. Generally higher pavement deflection, wider crack widths and nonuniform crack patterns were associated with failed pavement condition. The support conditions under CRCP are of particular significance relative to performance. Granular subbases with high stability and good internal drainage have shown good performance.

A COMPREHENSIVE PAVEMENT EVALUATION SYSTEM:

APPLICATION TO EVALUATION OF CRCP.

by

Eldon J. Yoder
Professor of Highway Engineering

Asif Faiz*
International Bank for Reconstruction and Development

Donald G. Shurig
Associate Professor of Civil Engineering

During the past several years a great amount of research has been concentrated on methods of making condition surveys and on techniques for pavement rehabilitation. This is particularly important from the standpoint of the Interstate system in the United States since, because of its age, there is a need to plan for its maintenance. Further, the states and counties have large investments in highways which are in the need of maintenance. The primary concern of most highway departments at the present time deals with the need for funding a maintenance management program to keep the existing highways operative.

The need for developing maintenance strategies has focused on development of methods for surveying and analyzing the condition of an existing pavement. These techniques have, by and large, centered on rapid methods of measuring pavement condition and have attempted to relate the condition of the pavement to the Present Serviceability Index (PSI). Along parallel lines,

*Formerly Graduate Instructor, Purdue University.

but often not coordinated with condition survey methods, has been the development of techniques for optimizing design and maintenance of pavement systems.

The purpose of this paper is to present a comprehensive pavement evaluation system that was developed at the Joint Highway Research Project, Purdue University. Another purpose is to demonstrate the use of the method as it was used to evaluate continuously reinforced concrete pavements (CRCP) in the state of Indiana.

The application of the method to CRCP is incidental to the central theme of the paper; the primary purpose is to present concepts of evaluation and how these concepts can be integrated to form a comprehensive evaluation system.

SURVEY STRATEGIES

At the outset it is necessary to define various surveys that might be made. Each of the surveys has its use, and likewise, each has its limitation depending upon many factors. The selection of the survey to use is dependent upon the judgement of the engineer and many times any given step in the evaluation process can be eliminated depending upon the actual factors under consideration. For purposes of this discussion use will be made of terms relating to three basic types of surveys: (1) reconnaissance surveys, (2) condition surveys and (3) evaluation surveys.

Reconnaissance Surveys

These surveys are generally carried out on a routine basis by most highway departments. They consist of visual inspection and a qualitative judgement of the condition of pavements made by a qualified field engineer. Often, this type of survey is the only one required and conclusions can be derived from it.

Condition Surveys

Condition surveys, at a given time, were made for the purpose of determining the condition of a pavement generally by use of roughometers, profilometers, etc. This type of survey is not intended to evaluate the structural strength of the pavement and generally no attempt is made to determine the reason for the pavement's condition.

Information from this type of survey can lead to the establishment of priorities and cost estimates for pavement rehabilitation.

Evaluation Surveys

The purpose of evaluation surveys is to determine the structural adequacy of the pavement and to determine causes for pavement defects that might be observed. These surveys are more inclusive and include both laboratory and field tests and accumulation of data which can lead to evaluation of the pavement structure.

The results of evaluation surveys can also lead to the establishment of priorities and cost estimates, but in addition, they permit recommendations relative to new designs and main-

tenance alternates that might be considered.

SEQUENCE OF THE COMPREHENSIVE EVALUATION SYSTEM

The complete system encompasses all of the steps defined above and permits an evaluation of maintenance priorities concurrently with the determination of the reasons for pavement defects. Figure 1 shows the sequence that is followed in the comprehensive pavement evaluation system. This is a six-step process as outlined on the flow diagram.

The evaluation process can be stopped during any one of the phases depending upon the needs of the highway department. For completeness, however, it is necessary to follow all of the phases sequentially.

Each of the phases of the survey are self-explanatory but each, in turn, has one or two important parts that must be observed if maximum information is to be obtained with minimum effort.

The condition survey, as envisioned in Figure 1, has at its heart two principle steps. First, it is necessary to stratify the data on the basis of known conditions at the site. Second, each of the strata are statistically sampled and only parts of the road sections are actually surveyed. Hence, stratification of the data along with a statistical sampling procedure immediately dictates that a statistical analysis be made of the data.

In the condition survey analysis, it is necessary to determine the factors which significantly affect the condition of the pavement which is observed. Many of the factors which are listed in the stratification process can be shown to be statis-

tically nonsignificant and hence they may be dropped from the analysis. It is necessary to make significance tests before proceeding to the evaluation survey.

As indicated on the flow diagram, however, the significance tests can be bypassed if it is desired simply to obtain data which indicate the extent of pavement distress.

After the significant factors influencing performance are determined, it is possible to make an evaluation survey in which test sections are statistically laid out and field tests made and samples of pavement components are obtained on a statistical basis. Appropriate field and laboratory tests can be made with these samples and an evaluation made of the pavement as shown in Phase V of the diagram. The primary feature of the evaluation survey is, again, stratification and sampling of portions of pavements.

It is possible to complete the process during any one of the phases listed on the flow diagram. The details of any given step depend on the results of the preceding phase. The decision whether or not to proceed through the comprehensive evaluation system is dependent upon the needs of the particular situation.

ILLUSTRATION OF THE METHOD

For illustrative purposes, the evaluation system will be demonstrated by means of a study made of continuously reinforced concrete pavement in the state of Indiana. The techniques, however, are applicable to any pavement and the sequential set of events would be followed in any case.

The use of continuously reinforced concrete pavements in Indiana dates back to 1938 when an experimental project was first built on U.S. 40 near Stilesville, Indiana. Since that time the mileage of continuously reinforced concrete pavement increased until the end of 1971 when 696 miles (1114 km) of equivalent two-lane CRC pavements were in service in the state.

In 1972, a continuing study of the performance of CRC pavements was initiated by the Joint Highway Research Project at Purdue University. The objective of the study was to evaluate and to recommend design and construction techniques that would result in better performance of continuously reinforced concrete pavements.

The evaluation of CRCP in Indiana followed the sequential steps as outlined in Figure 1.

PHASE I RECONNAISSANCE SURVEY*

Distress was noted on some sections of continuously reinforced concrete pavement in Indiana as early as 1970. The development of distress reached alarming proportions at certain locations by 1972. It was at this time that the evaluation process was started.

A reconnaissance survey was conducted on a section of one road, I-65, and encompassed only the northbound lanes of the four-

*The use of the terms PHASE I, PHASE II, etc. refers to the steps of the evaluation sequence as outlined in Figure 1.

lane divided facility. The road at the location surveyed traverses glacial drift of Wisconsin Age and the subgrade is highly variable ranging from sands and gravels to plastic clays. Subbase materials were largely non-stabilized gravels with some crushed stone and bituminous-stabilized gravel. A variety of construction and design variables were incorporated in the road with the result that several design and construction features which affect performance became immediately noticeable.

The initial survey consisted of: crack counts, tabulations of failed areas, observations of pumping, poor drainage conditions and other factors. No attempt was made at this time to sample the pavement on a statistical basis but rather the entire length was surveyed visually.

The performance of the pavement then was correlated in general with the factors listed below:

1. Subgrade type (granular versus clay)
2. Subbase type (gravel, crushed stone, bituminous stabilized)
3. Steel fabrication (bar mats, wire fabric, loose bars)
4. Steel placement (depressed, preset on chairs)
5. Method of paving (slipformed, sideformed)
6. Slump of the concrete - as obtained from construction records

The results of this survey indicated, although not conclusively, that the following factors were probable contributors to poor performance.

1. Gravel subbases
2. Use of bar mats
3. Clay type subgrades
4. Slipform paving

Since no definitive conclusions could be reached on the basis of the first survey, a statewide condition survey was subsequently planned. Note that these were tentative conclusions and that they were changed after further study.

PHASE II STATEWIDE CONDITION SURVEY

In order to arrive at definitive conclusions and to include a large range of construction and design variables the scope of the condition survey was setup to include all the CRC pavements in Indiana. A sampling procedure was used to design the field survey and statistical methods were used to analyze the resulting data.

Study Design

The intent of the study design was to ensure the inclusion in the study of every CRCP contract that had been completed up to the time of the survey. A further purpose was to provide an inference space for the proposed analysis that would encompass all the factors under investigation.

Sampling Procedure

A stratified random sample of CRC pavements was used in the field survey. Stratified random sampling is a plan by which the population under consideration (in this case, all the CRCP contracts in Indiana) is divided into strata or classes according

to some principle significant to the projected analysis. This is followed by sampling within each class as if it were a separate universe. The aim in stratification is to break up the population into classes that are fundamentally different in respect to the average or level of some quality characteristics (6).

Only one simple random sample was obtained from each stratum or class. Such a sample or unit of evaluation was designated as a field survey section. Each field survey section was a 5,000-ft length of pavement. The location, relative to the direction of lanes, and beginning of each section were selected from the total length of CRC pavement in each stratum by the use of random number tables. Care was taken that a randomly selected pavement length was located approximately 200 to 300 ft. away from the exact end or beginning of a construction contract.

The survey sections were stratified on the basis of the following factors: contract, method of paving, method of steel placement, method of steel fabrication, type of subbase, and type of subgrade. These factors are described in detail in the section on statistical design. Data relative to these factors were obtained from construction survey records.

Statistical Design

A $2 \times 2 \times 3 \times 4 \times 2$ factorial design with unequal subclass frequencies was used to study the factors influencing the performance of CRC pavements. A number of covariates or concomitant variables were superimposed on the factorial. The layout of the statistical design is shown in Figure 2, which also indicates the independent

factors and their corresponding levels selected for this investigation. Though a completely randomized factorial design was assumed for the analysis, this assumption may be questioned on the grounds that a restriction on randomization could have been caused by the use of five different survey teams.

Data Collection

The survey sections were assigned at random to the five survey parties. Owing to limitations of time and scheduling, it was not possible to assign an equal number of sections to each of the survey parties. The primary distress variables included close parallel cracks, random bifurcated and intersecting cracks, spalled cracks, edge pumping, and defects as noted by breakups, punchouts, and patches.

Regarding parallel cracks, only those having a spacing closer than 30 in. (76.2 cm) were considered. Parallel cracks and random bifurcated and intersecting cracks were logged on the basis of linear feet of longitudinal pavement containing the particular type of crack under consideration. In addition, cracks that showed spalling were counted in three categories, depending upon the degree of spall. Defects were noted as breakups (obvious structural failures) or those areas that had been previously patched with asphalt or portland cement concrete. The defects were logged on the basis of total number observed per section. An estimate of the area of the defect was also made.

Information relating to grade, curvature, pumping and general data on the physical features of the highway were also cataloged. The exact location of patches and breakups was noted

on the log sheet. In addition, these locations were either sketched or photographed.

PHASE III CONDITION ANALYSIS

The data obtained from the statewide CRCP condition survey were statistically analyzed by using a weighted least squares analysis of covariance procedure. This procedure was necessitated because of unequal subclass cell frequencies in the data. In this situation, the different comparisons with which the sums of squares are associated become nonorthogonal and usual analysis of covariance leads to biased test procedures.

The covariance analysis results reported in this study were obtained by using LSMLGP (Least Squares Maximum Likelihood General Purpose Program), a program at the Purdue University Computer Center. This program uses a general weighted least squares procedure (6) which can be applied to missing value problems where cell frequencies are unequal and also where data are not available for certain subclasses. The program can only handle main effects and two-factor interactions, but has provisions for incorporating covariates (concomitant variables) in the analysis. The method of analysis is given in reference 7.

Results from Statewide Condition Survey

The analysis of data collected during a statewide survey of continuously reinforced concrete pavements in Indiana, revealed a number of significant results and correlations. The survey was statistically designed whereby each construction contract was required to be in the study. At least one survey sec-

tion, 5000 ft in length, was sampled from each contract. In some cases, more than one 5,000-ft section was evaluated within a construction contract because of the stratification of factors used in the statistical study. The results of the statewide survey provided some definite indications relative to causes of distress in CRC pavements.

Regarding first the extent of distress in the state, the following data were indicated:

1. 69.7 percent of CRCP sections surveyed did not show any defects.
2. 26.9 percent of CRCP sections had from one to five defects per section.
3. 3.4 percent of CRCP sections had more than five defects per section.

This information was based on 89 sections, each 5,000 ft long, of equivalent two-lane or three-lane CRC pavement.

The following summary of results pertains to the effect of various factor influencing the performance of CRC pavements in Indiana.

1. Subbase type was found to be a significant contributor to the performance of CRC pavements; gravel subbases showed the poorest performance. Crushed stone and slag subbases, in general, showed good performance, and at the time of the survey the bituminous-stabilized subbases showed little or no distress (since the condition survey, breakup has been encountered on some of the bituminous-stabilized subbase sections).

2. For most combinations of methods of paving and steel fabrication, depressed steel performed better than pre-set steel on chairs.
3. All other factors being constant, loose bars showed good performance compared to the use of bar mats and wire fabric.
4. Concrete slump had a significant effect on pavement performance; the optimum slump range was between 2.0 and 2.5 in. Slump values of 1.5 in. and greater showed generally good results.
5. Pavements that were sideformed, performed the same as those that were slipformed.
6. Distress of CRC pavements is associated with traffic.
7. The primary mode of pumping of CRC pavements is edge pumping. The results of the condition survey indicated that pavements with gravel subbases were more susceptible to pumping. Pavements with crushed-stone and bituminous-stabilized subbases showed some indication of pumping, while pavements with slag subbases did not pump.
8. Subgrade parent material type (granular or fine-grained) was not a significant contributor to performance of CRC pavements. This refers to type of subgrade and not to other factors such as degree of compaction.

Summary Statement - Condition Survey

The conclusions reached from the results of the condition

survey were valid from the standpoint of identifying significant factors which influenced performance of CRCP. The conclusions differed in some respects to those reached in the first survey. The data also showed the extent of distress of the pavements on a statewide basis. It was possible to infer reasons for performance (for example gravel subbases vs stone subbases or use of chairs vs depressed steel), but these reasons could not be determined with certainty. Hence, an evaluation survey was set up to delineate possible causes and effects for the relative performance.

PHASE IV DETAILED EVALUATION SURVEY

With respect to the broad framework of the study, the detailed field investigation constituted the primary element of the fourth phase of the research. A laboratory testing program was included in the fourth phase. These two steps (field and laboratory tests) of the research are presented together because the results obtained from the two parts must be analyzed together. A primary purpose of Phase IV was to determine the effect of pavement materials in performance.

Design Study

The field investigation was designed to include only the CRC pavements that are part of the Interstate Highway System in Indiana. As a result only 9-in. thick pavements were evaluated. This measure was taken for the purpose of obtaining a homogeneous set of pavement sections with respect to pavement thicknesses and percentage of steel reinforcement.

The design of the detailed evaluation study was based on the results of the statewide condition survey. The factors that were found to be statistically significant in the condition survey were used as the stratification criterion for sampling the test sections for the field study. The stratification scheme consisted of the following factors:

1. method of paving (slipformed; sideformed)
2. method of steel placement (depressed steel, steel preset on chairs)
3. type of steel reinforcement (wire fabric, bar mats, loose bars)
4. type of subbase (gravel, slag, crushed stone, bituminous stabilized)

A total of 31 test sections were included in the field investigation.

Delineation of Test Sections

The test sections used in the field investigation were delineated according to the following criteria:

1. The test section, 1000 ft in length, was a tangent section with flat gradients (less than ± 1 percent) under uniform grade conditions, i.e., completely under fill, cut or at grade conditions.
2. It was required that the test section lie within the internal portion of the continuous slab, substantially removed from construction or expansion joints.
3. The test section was located wholly within one physiographic unit, e.g., ground moraine, glacial terrace,

flood plain, etc.

4. Wherever possible, a test section was located to include at least one location where significant distress as indicated by a breakup or a patch was observed.
5. The structural components of the pavement section were required to conform to a combination of levels of factors comprising the stratification scheme.
6. The 1000-ft test section was located within one of the randomly selected 5000-ft survey sections used in the statewide condition survey.

Collection of Field Data

The typical layout and the data collected at each test section are outlined in Figure 3. The first step in the data collection procedure was to divide the test section into ten segments of 100-ft length each. Where possible two test locations, corresponding to failed and good pavement conditions respectively, were selected within each test section. A failed-test location was defined as one showing distress, indicated by a patch or a breakup. Conversely, a good-test location was defined as one showing no apparent distress. Two test locations were also used in test sections, which did not show any indication of a failure. One location corresponded to an area with a uniform and evenly spaced crack pattern while the other was representative of an area with a relatively more dispersed and nonuniform transverse cracking. These crack patterns were evaluated subjectively by visual examination. In certain sections without failures,

tests were conducted only at one location because of limitations of time.

At a test location, tests on the subbase and the subgrade were made at two points. One test point, located at the pavement-shoulder interface, was designated as the shoulder position. The other test point was the hole through the pavement from which a concrete core had been extracted. This was designated as the core-hole position.

A series of tests performed at a test section consisted of the following:

Deflection Measurements: Pavement deflections were evaluated with the Dynaflect (11,12). At the center of each 100-ft segment two deflection measurements were taken, one at a crack position, and the other at the mid-span position between two transverse cracks. These measurements were taken along the center line of the traffic lane, by using only the sensor between the steel wheels.

A second set of deflection measurements were obtained by using all the sensors and were taken: across the traffic lane, at 1.0 ft, 3.5 ft, and 6.0 ft from the outside pavement edge, approximately corresponding to the outside edge, the right wheel path and the lane centerline positions, respectively. The transverse deflections were determined at both a crack position and an adjacent mid-span position between two transverse cracks.

Crack Width Measurements: Crack widths were measured by means of a 50X, direct measuring pocket microscope. The points, where

crack width measurements were made, corresponded to the positions along a crack where deflections were evaluated.

Crack Interval Measurements: Pavement segments 50 ft in length were first measured on either side of a test location. This was followed by crack interval measurements along the pavement edge over the 100-ft section centered on a test location. In addition, the number of crack intersections were counted over the 100-ft section at each test location.

Subgrade and Subbase Evaluation: In-place penetration tests were made on subbase and subgrade by means of the High Load Penetrometer (2) and the Dynamic Cone Penetrometer(13), respectively. These tests were performed at both core-hole and shoulder positions at each of the two test locations. In all, eight penetrometer tests, four each on subbase and subgrade were performed at each test location. The penetration test values were converted to in-place California Bearing Ratio (CBR) by the use of calibration charts. Before conducting the penetration tests, in-place nuclear density and water content determinations were made on the subbase and the subgrade. As a check on nuclear moisture content and density measurements, moisture content of the subbase and subgrade materials was determined by the standard procedure and subgrade density was measured by means of a thin-walled tube sampler. These tests were made at the shoulder position after the penetration tests. At the completion of a series of tests on the subbase or subgrade, material was sampled from under the pavement at the pavement-shoulder interface for

laboratory testing. In case of failed locations, care was taken to sample the material some distance away (about 5 ft.) from the failed area. In most cases the subbase material directly under the failed area had densified to a degree that it could not be extracted by a pick.

The two methods of penetration tests are shown in Figure 4. These penetration tests permit rapid determination of the relative stability of insitu materials. The penetrometer shown in Figure 4a was used on fine-grained soils, whereas the instrument shown in Figure 4b was used on granular materials (bases and subbases). The test values were converted to CBR values (see references 2 and 13 for correlations) although this would not have been necessary from the standpoint of the evaluation process.

Concrete Cores: Concrete cores were obtained from the two test locations within each test section. These cores were taken from the traffic lane, close to the point from where the subgrade and subbase materials were sampled.

Laboratory Testing Program: Concrete cores obtained from the field were subjected to the following tests:

- a. Specific gravity and absorption tests
- b. Pulse velocity measurements
- c. Bulk density measurements

Next the cores were cut and segments without any steel from above and below the level of reinforcement were tested

for: specific gravity, water absorption, pulse velocity, bulk density, and splitting tensile strength.

The series of tests on subgrade soils and granular subbase materials included standard classification and compaction tests. Permeability tests, utilizing a constant head permeameter, were made on selected samples of slag, crushed stone, and gravel subbases.

For bituminous-stabilized subbase materials, the grain-size distribution and asphalt content were determined.

All laboratory tests were conducted in a random order, in order to distribute any random variation in test procedures or among testing personnel over all the measurements.

PHASE V EVALUATION

Approach to Data Analysis

The characteristics of the design of the field study offered two dichotomies that could be profitably used in data analysis. These were:

1. Comparison of failed-test locations with good-test locations, within test sections showing significant distress.
2. Comparison of test sections showing distress (as indicated by a breakup or a patch) with test sections in good condition and showing no apparent distress.

The following paragraphs present a portion of the analysis of just the second item given above. These data are presented to illustrate techniques for designing a maintenance research program on the basis of the results.

The primary aim of this comparative analysis was to identify material properties and performance characteristics that are indicators of potential distress in CRCP. Only data from structurally sound locations were included in the study. The objective of using such data was to isolate inherent deficiencies in the pavement structure even where no superficial evidence of distress was present.

For failed-test sections, the data were obtained from structurally sound (good -test) locations within test sections showing significant distress. Where two test locations were sampled within a test section without distress, data from only one randomly selected test location were used.

This comparison also includes test properties representative of the whole test section such as: concrete slump, temperature variables, load repetitions, and deflection measurements taken at 100-ft intervals along the length of the test section.

Analysis of Data

The number of test sections in each of the "without" and "with" failure categories were 15 and 16 respectively. Differences between the two categories with respect to material properties and performance characteristics were tested by the t-test. Sample variances were pooled where homogeneity of variance was indicated by the F-test; otherwise, the t-test was based on estimates of separate variances for the two categories. The hypotheses for the statistical tests were developed on basis of comparisons between good and failed-test locations.

In other cases, where a factorial arrangement was used,

data were analyzed within the framework of a nested factorial design (1). An equal number of randomly selected test sections were nested within each of the pavement condition categories.

All data were analyzed by appropriate computer programs.

Space limitations will not permit a detailed discussion of the ANOV models used in the analysis. However, it is pertinent to note that of the factors studied in the evaluation survey, the subbase was found to be prime suspect for cause of much of the distress. The ANOV results showed no significant effect of subgrade CBR. The results of t-test indicated no difference between percent compaction of the subgrade and subbase in failed vs no-failed sections. In every case, however, percent compaction was low.

Properties of Granular Subbases

In view of the earlier analyses that brought to light significant differences among the properties and behavior of crushed stone, slag, and gravel subbases, the subbase data was first segregated by subbase type. The properties of the gravel subbases were comparatively analyzed relative to poor and adequate pavement condition. Such an analysis could not be done on the other subbase types owing to paucity of data. Finally the variation of important subbase characteristics with subbase type was tabulated.

The CBR data for gravel subbases was analyzed using ANOV. Only ten test sections were used for each condition type. Results derived from this analysis indicated little difference in subbase

CBR relative to pavement condition. On the other hand, the CBR values obtained at the core-hole (an average CBR of 44 percent) were significantly larger than those measured at the shoulder (an average CBR of 35 percent). In any case, the CBR values were invariably low.

The grain-size distribution, percent compaction, and permeability of gravel subbases were essentially the same at both the sections with and without failures - as was shown by the results of t-tests on these properties. Even so, the degree of compaction achieved for the gravel subbases was uniformly low (about 93 percent of standard AASHTO on the average).

Comparison of Subbase Types. Table 1 describes the variation of subbase CBR, permeability, and degree of compaction with subbase type. Though no clear differences in the properties of the gravel subbases were evident between sections with failures and sections showing no apparent distress, the gravel subbases were not sufficiently compacted and had relatively low permeability and strength.

The results bring to light important differences among the properties of the different subbase types. Crushed stone subbases were the most permeable while slag subbases had the lowest permeability. The relatively poor water transmission characteristics of the slag subbase was more than balanced by its high strength, as indicated by CBR.

Interaction Between Permeability and Strength: It is worthwhile

Table 1. Effect of Subbase Type on Pavement Condition

Type of Subbase	Condition of Test Sections	No. of Test Sections	Subbase CBR		Permeability, k	Compaction
			Shoulder	Core		
Gravel	With Failures	13	33.5%	38.0%	978.9 ft/day*	91.5%*
	Without Failures	10	35.9	45.2	702.6**	93.2**
Slag	With Failures	1	95.0	100.0	30.0	117.2
	Without Failures	3	81.0	96.6	142.9	100.6
Crushed Stone	With Failures	1	32.0	41.0	1369.7	89.9
	Without Failures	1	90.0	59.0	2497.1	85.3

* Average of values from nine test sections.

**Average of values from ten test sections.

Note: Data from structurally sound test locations.

to note that concrete pavement performance is also a function of the interaction between subbase permeability and strength (CBR). In Figure 5, the estimated field permeability values are plotted against field subbase CBR values measured at the shoulder-slab interface. These values pertain to 46 test locations of the detailed field study. Test data for crushed stone and slag subbases are shown with separate indicators. In addition, values obtained at failed-test locations are differentiated from the values at good-test locations. The data were grouped in nine categories corresponding to three levels each of subbase CBR and permeability. For low subbase strength (CBR < 40 percent), mainly gravel subbases, the percentage of failed test locations decreased from 53 percent in the low permeability group ($k < 100$ ft/day) to 25 percent in the high permeability group ($k > 1000$ ft/day). For medium subbase strength (40 percent < CBR < 80 percent), no failures were observed where permeability was greater than 1000 ft/day. Where subbase strength (CBR > 80 percent) was high (applies only to slag and crushed stone subbases) no failures were indicated irrespective of permeability.

Deflection as a Predictor of Performance

As would be evident, the experimental design associated with section-wide deflection measurements was somewhat inadequate, as most effects cannot be tested due to restriction errors.

The major interest in the analysis of deflection measurements, taken over the total extent of each test section at 100-ft intervals, was to determine if pavement condition, as indicated

by the presence or absence of failures, could be differentiated by such section-wide measurements.

Figure 6 shows the deflection profiles developed from deflection measurements made at 100-ft intervals on three test sections with gravel subbases. The values shown are the average of crack and midspan deflections, measured 6.0 ft from the pavement edge. Profiles No. 1 and No. 2 apply to two test sections, separated by the median strip, on Construction Contract R-7677, Interstate Highway I-65. At the time of the field study, the test section with deflection profile No. 2, had four concrete patches and four breakups and substantial edge pumping was indicated over the section. The test section on the opposite lanes, illustrated by deflection Profile No. 1, had no breakups, patches or any other indication of significant distress, although extensive edge pumping was observed. Yet the deflection Profile No. 1 exhibits higher overall deflections than the Profile No. 2. This is explained with reference to the Profile No. 3, obtained at a test section on Contract R-7913 (I-65). This latter contract has been completely free of distress in spite of having been under traffic since 1970. Deflection Profile No. 3 represents excellent pavement condition as indicated by deflections of a relatively small magnitude (less than 0.50 milli-in.). This should be the deflection pattern of a pavement giving good performance. The deflection pattern given by Profile No. 1 signified potential trouble, although no physical distress was indicated at the time of the field study. The high deflections

reflect loss of support caused by the erosive action of pavement pumping and/or consolidation. Under the action of repeated loads, it becomes a matter of time before distress will be manifested in the form of breakups. After extensive pavement distress, the discrete segments of the broken continuous slab attempt to conform to the shape of the pumped subbase that had developed voids earlier. This settlement of the pavement slab can be observed by visual inspection of a failed location. The deflections observed at this stage are smaller than those before the breakup because now the slab is again in contact with the subbase and has regained some of the lost support. This is the condition shown in Profile No. 2.

As a rule, sections of pavement showing signs of potential distress had higher deflections than those that had already failed (Profile No. 1 vs Profile No. 2 in Figure 6). Hence, it was concluded that pavement deflection is a good indicator of potential distress. The pavement represented by Profile No. 1 has recently shown extensive distress.

Summary of Results

The comparison of test sections with failures as opposed to sections without failures, relative to material properties and performance characteristics evaluated at structurally sound

test locations, resulted in a number of significant results. Similarly the evaluation of section-wide pavement characteristics also established some significant trends. These findings bring to light inherent deficiencies in the pavement structure that eventually lead to distress.

The following is a summary of the significant results:

1. Subgrade Properties: The only significant result in the analysis of subgrade properties showed that subgrade soils at sections without failures were relatively more coarse grained and sandy than sections where failures had occurred.
2. Subbase Properties: This analysis clarified the reasons for the better performance of certain subbase types. Crushed stone subbase, at the section without failures was found to possess a high strength (CBR of 90 percent) and excellent internal drainage (over 2000 ft/day). The failure on another section with a crushed stone subbase was a function of poor stability (very low CBR), resulting from inadequate compaction. The good condition of pavements on slag subbases was due to the very high stability (CBR of over 100 percent) of this subbase. At structurally sound locations, gravel subbases were found to have a moderately high permeability but showed poor stability characteristics, probably a function of insufficient compaction.
3. Concrete Properties: It was shown that sections showing no failures were paved with a higher slump concrete.

The results of data analysis further indicated that the modulus of elasticity of concrete had a significant bearing on pavement condition. Concrete cores obtained from sections without any distress were tested to have an average dynamic modulus of elasticity of 6.15 million psi whereas cores, obtained from good locations on sections that had failures, had an average dynamic modulus of 4.97 million psi.

4. Dynamic Pavement Deflection: Dynamic pavement deflections were shown to be a good indicator of pavement condition if used judiciously. Once the continuous slab breaks up into discrete segments, the usefulness of deflections measurements is impaired. As expected at good test locations, no difference in dynamic deflections was observed between sections with failures and sections without failures.

An evaluation of section-wide deflection measurements taken at 6.0 ft from the pavement edge showed that for 9-in. CRCP, dynamic deflections less than 0.5 milli-in., as measured by Dynaflect, are indicators of good pavement condition. Deflections in the range of 0.6-0.9 milli-in spell a potential distress condition while values above 1.0 milli-in. are indicators of severe distress with a high probability of pavement breakups.

5. Crack Width: It was noted that crack widths observed at test sections with failures were significantly wider than those measured at good test sections, even though

crack widths at only structurally intact locations were measured. The average crack width at good sections was 0.0087 in.

6. Crack Spacing: No difference in either the mean crack spacing or the variance of crack intervals was observed between sections falling in the two categories. The variance of crack spacing at failed test locations was significantly higher than the variance at good locations. Frequent incidence of bifurcated cracks, as well as closely spaced cracks which may intersect at a later date, was observed to be associated with failures. Also, high incidence of very closely spaced cracks is indicative of incipient failure.

PHASE VI DESIGN OF MAINTENANCE TYPES

The evaluation of significant factors relating to performance of CRCP led to recommendations for altering the designs of the future. These recommendations are not included herein. As a part of these recommendations, however, it became obvious that there was a need to recommend maintenance strategies that might be adopted.

Data relative to the most economical maintenance were meager, and as a result, a field experiment was established to evaluate this factor. This field experiment was evolved on the basis of known factors which have significantly influenced performance of CRCP in Indiana, and was established for a specific section of Interstate highway to combat known contributors to performance,

i.e., poor drainage condition, high deflections, etc.

The endpoint of the research could only be accomplished by dividing a section of highway into smaller units with similar characteristics. A section of Interstate pavement 4.6 mi (7.4 km) in each direction, or a total of 9.2 mi (14.8 km) was selected as the test pavement.

This particular section was selected for study since it contains all of the significant features identified as major contributors to performance of CRCP. It has a gravel subbase and bar mats on chairs. These are three important factors identified earlier as contributors to potential failure. This pavement has shown, as predicted, very poor performance.

Objective of Research

The maintenance types considered were determined on the basis of results of the evaluation. Hence, the types of maintenance considered were directed to three principle factors:

1. Improvement of drainage of subbase.
2. Methods of reducing pavement deflection.
3. Methods of patching failed areas.

Initial Tests

Deflection readings were taken in the Fall of 1974 with the Dynaflect at 25-ft (7.6 m) intervals over the study area. At the same time, a condition survey of the pavement was made noting the locations of breakups, patches, intersecting cracks and combination cracks.

Method of Selecting Study Sections

Using the data derived from the above tests, three factors were chosen as indicative of the overall condition of the pavement. These were: (1) lineal feet of cracks spaced less than 30 in. (76.2 cm) plus lineal feet of intersecting cracks per 100-ft (30.5 m) station, (2) total area of patching or breakups per station and (3) maximum deflection per 100-ft (30 m) section.

Using this technique, the sections of pavement were then stratified and assigned rating numbers of 1 to 12 as shown in Figure 7.

Selection of Maintenance Methods

An attempt was made to apply as many types of appropriate maintenance as possible to the various ratings. Table 2 shows the types of maintenance that were considered to be appropriate for the given rating numbers. Input into this selection was given by FHWA, ISHC and Purdue personnel.

Layout of Study Sections

The layout of study sections of a given maintenance type was governed by four criteria:

1. It was desirable to make a section of one type of maintenance as long as possible;
2. Retain at least one "no-maintenance control section" for each rating number 1-12;
3. Use as many different types of maintenance methods as possible for each rating number;

Table 2 Possible Maintenance*

Rating No.	Type of Maintenance
1 (7)	No Maintenance (7)
2 (10)	No Maintenance (5); Patch (5)
3 (2)	No Maintenance (1); Patch (1)
4 (5)	No Maintenance (1); Underseal & Overlay (2); Underseal (0); Overlay (1); Concrete Shoulders (1); Drain (0)
5 (11)	No Maintenance (1); Patch, Underseal & Overlay (4); Patch & Underseal (1); Patch & Overlay (1); Patch & Concrete Shoulders (0); Patch & Drain (3); Patch, Drain & Concrete Shoulders (1)
6 (3)	No Maintenance (1/2); Patch, Underseal & Overlay (1/2); Patch & Underseal (1); Patch & Overlay (0); Patch & Concrete Shoulders (0); Patch & Drain (1)
7 (3)	No Maintenance (1); Drain (1); Overlay (1)
8 (5)	No Maintenance (1); Patch & Overlay (1); Patch & Concrete Shoulders (1); Patch & Drain (2); Patch (0)
9 (7)	No Maintenance (2); Patch & Overlay (2); Patch & Concrete Shoulders (2); Patch & Drain (1); Patch (0)
10 (2)	No Maintenance (1/2); Underseal & Overlay (1/2); Concrete Shoulders (1); Drain (0)
11 (0)	No Maintenance (0); Patch, Underseal & Overlay (0); Patch & Drain (0); Patch & Concrete Shoulders (0); Full Depth Bituminous (0)
12 (5)	No Maintenance (1); Patch, Underseal & Overlay (0); Patch & Drain (1); Patch & Concrete Shoulders (1/2); Full Depth Bituminous (1); Patch, Underseal, Overlay, Drain & Concrete Shoulders (1); Patch, Drain & Concrete Shoulders (1/2)

() indicates the number of sections of each type.

*This list of possible maintenance is considered to be a "shopping list" of various procedures. These were greatly reduced in number based on length of section, etc.

4. Allocate the maintenance to be used to the rating numbers with the fewest actual sections of that rating first. (Note that this criterion is a means for attaining the first three criteria.)

SUMMARY

In this paper the authors have outlined a comprehensive system for pavement condition evaluation. It has been the primary purpose to outline principles that can be used for a variety of pavements. The method has been illustrated using an evaluation of continuously reinforced concrete pavements. The techniques, however, are not unique to this type of pavement but have application to all types of pavements under a variety of traffic and environmental conditions.

The heart of the method lies in stratification of the known factors surrounding the pavement, and along with this a statistical analysis of the data. It is necessary to follow a sequential series of events, although the process can be concluded at several locations depending on the needs of the engineer.

REFERENCES

1. Anderson, V. L., McLean, R. A., Design of Experiments - A Realistic Approach, Marcel Dekker Inc., New York, 1974, 418 pp.
2. The Boeing Company, "High Load Penetrometer Soil Strength Tester", Document No. D6-24555, The Boeing Company, Commercial Airplane Division, Renton, Washington, 1971, pp. 1-16.
3. Burr, I. W. and Foster, L. A., "A Test for Equality of Variances", Department of Statistics, Purdue University, Mimeo Series 282, April 1972.
4. Cashell, H. D. and Teske, W. E., "Continuous Reinforcement in Concrete Pavements", Proceedings, Highway Research Board, Vol. 34, 1955, pp. 34-56.
5. Cedergren, H. R., et. al., "Guidelines for the Design of Subsurface Drainage Systems for Highway Structural Sections", Offices of Research and Development, Federal Highway Administration (FHWA), Washington, D. C., 1972, 25 pp.
6. Deming, W. E., Some Theory of Sampling, Dover Publications, Inc., New York, 1950, pp. 213-214.
7. Faiz, A. and Yoder, E. J., "Factors Influencing the Performance of Continuously Reinforced Concrete Pavements", Record 485, Transportation Research Board, Washington, D.C., 1974, pp. 1-13.
8. Faiz, A. and Yoder, E. J., "Evaluation of Parameters Significantly Influencing the Performance of CRC Pavements", presented at the 1974 Annual Convention of American Concrete Institute, San Francisco, April 1974 (to be published).
9. Harvey, W. R., "Least Squares Analysis of Data with Unequal Subclass Frequencies", Agriculture Research Service, U.S. Department of Agriculture, ARS 20-8, 1960.
10. Highway Research Board, "Continuously Reinforced Concrete Pavement", NCHRP Synthesis of Highway Practice, No. 16, 1973, pp. 1-18.
11. Scrivner, F. H., et. al., "Detecting Seasonal Changes in Load-Carrying Capabilities of Flexible Pavements", NCHRP Report 76, Highway Research Board, 1969, 37 pp.
12. Scrivner, F. H., et. al., "A New Research Tool for Measuring Pavement Deflection", Record 129, Highway Research Board, 1966, pp. 1-11.

13. Van Vuuren, D. J., "Rapid Determination of CBR with the Portable Dynamic Cone Penetrometer, The Rhodesian Engineer, Paper No. 105, Salisbury, 1969.
14. Williamson, T. G., and Yoder, E. J., "An Investigation of Compaction Variability for Selected Highway Projects in Indiana," Record 235, Highway Research Board, 1968, pp. 1-12.
15. Yoder, E. J., "Pumping of Highway and Airfield Pavements", Proceedings, Highway Research Board, Vol. 36, 1957, p. 388.
16. Yoder, E. J., and Gadallah, A. A., "Design of Low Volume Roads," paper presented at the Kuwait Conference on Low Cost Roads, November, 1974.

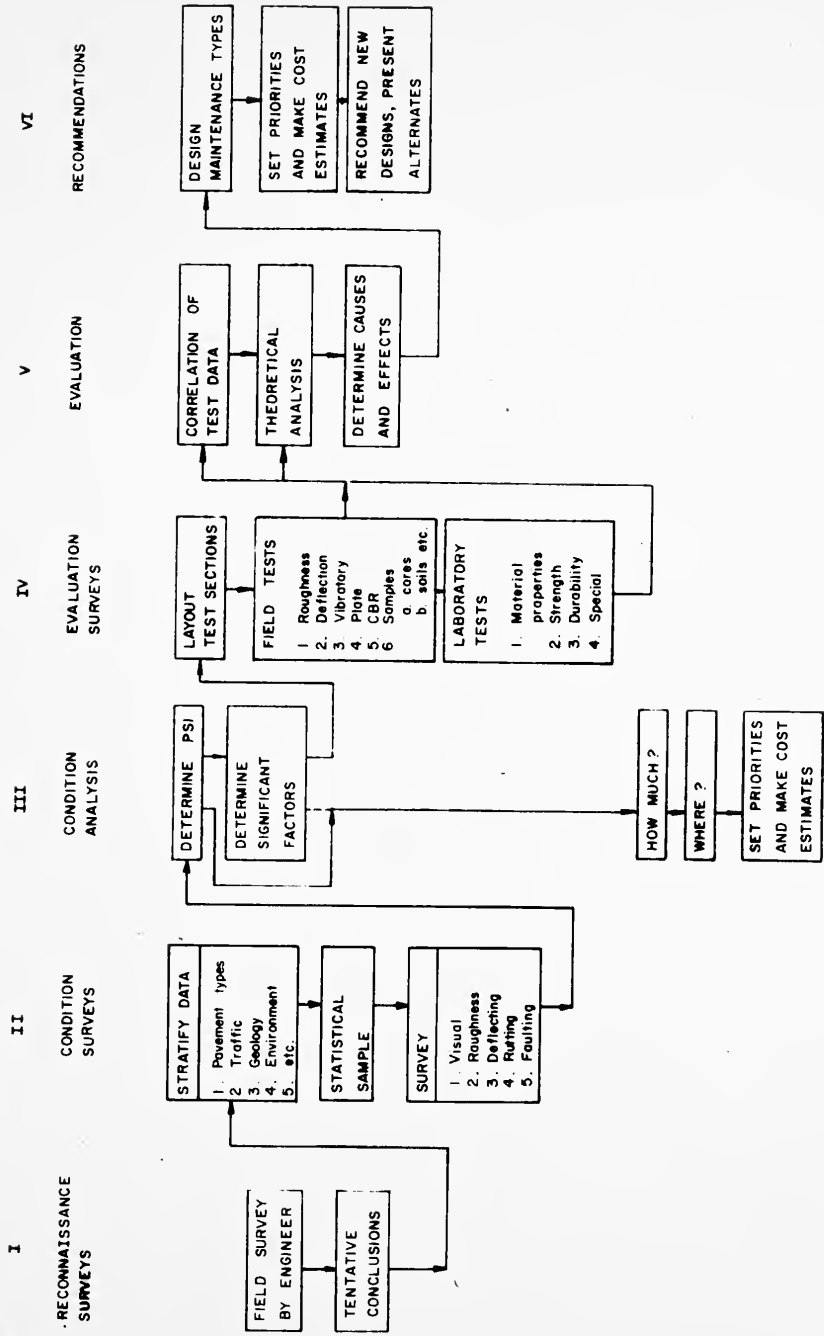
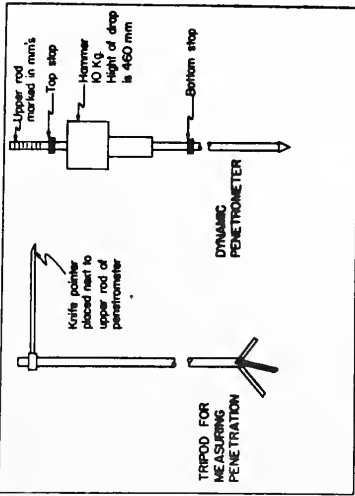
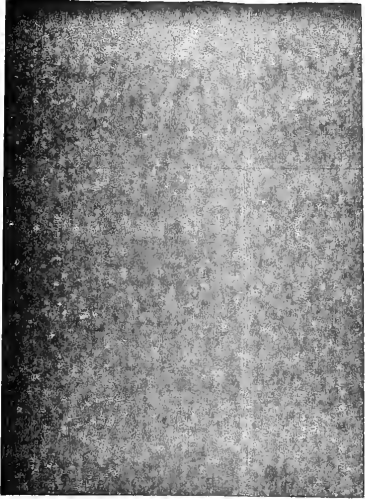
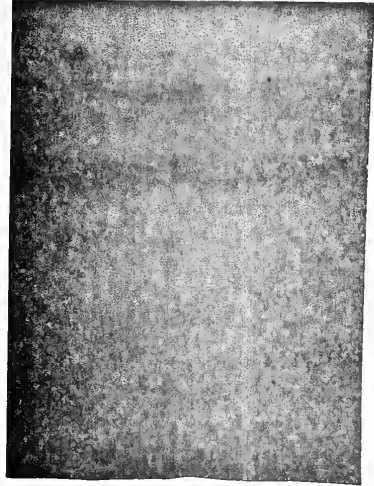

FIG. 1 SEQUENTIAL PROCESS OF PAVEMENT EVALUATION

FIG. 2 FACTORIAL DESIGN FOR STUDY OF FACTORS INFLUENCING CRCP PERFORMANCE

Method of Paying Method of Steel Placement Method of Subbase or Type of Fabrication		Slipformed						Side Formed					
		Chairs			Depressor			Chairs			Depressor		
		Loose Bars	Bar Mats	Wire Fabric	Loose Bars	Bar Mats	Wire Fabric	Loose Bars	Bar Mats	Wire Fabric	Loose Bars	Bar Mats	Wire Fabric
		Fine Grained	Bituminous Stabilized	9,8	8		9,8	8,8	8,8,8				
Gravel	9,9,9,8		9,9,9,9,8,8,7,7	9,9,9,8,8,8		9	9,9,9,8			9,8,8,8		8	9,9,9,9,9,8
Crushed Stone	9,7,7,7,7,7			9,9,8			9,8,8,7		9				9
Slag						9,8,8,8	9						9
Granular	Bituminous Stabilized	8			8,8	8,8							
	Gravel		9	8		8	9			9		8	9,9
	Crushed Stone			9			9		9				9
	Slag					8,8							

Numbers in cells denote thickness of CRC pavement in inches.



(g) DYNAMIC CONE (FINE GRAINED SOILS)

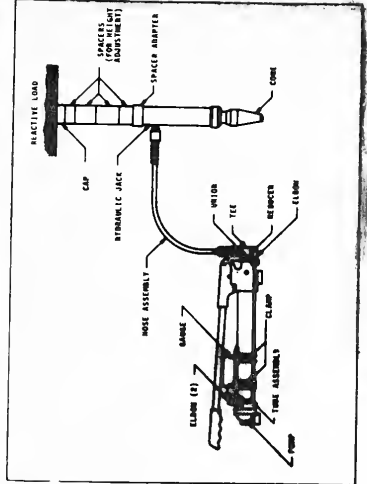

(h) HIGH LOAD CONE (GRANULAR SOIL)

FIG. 4 TWO METHODS OF RAPID CBR TESTS (FROM YODER AND GADALLAH)

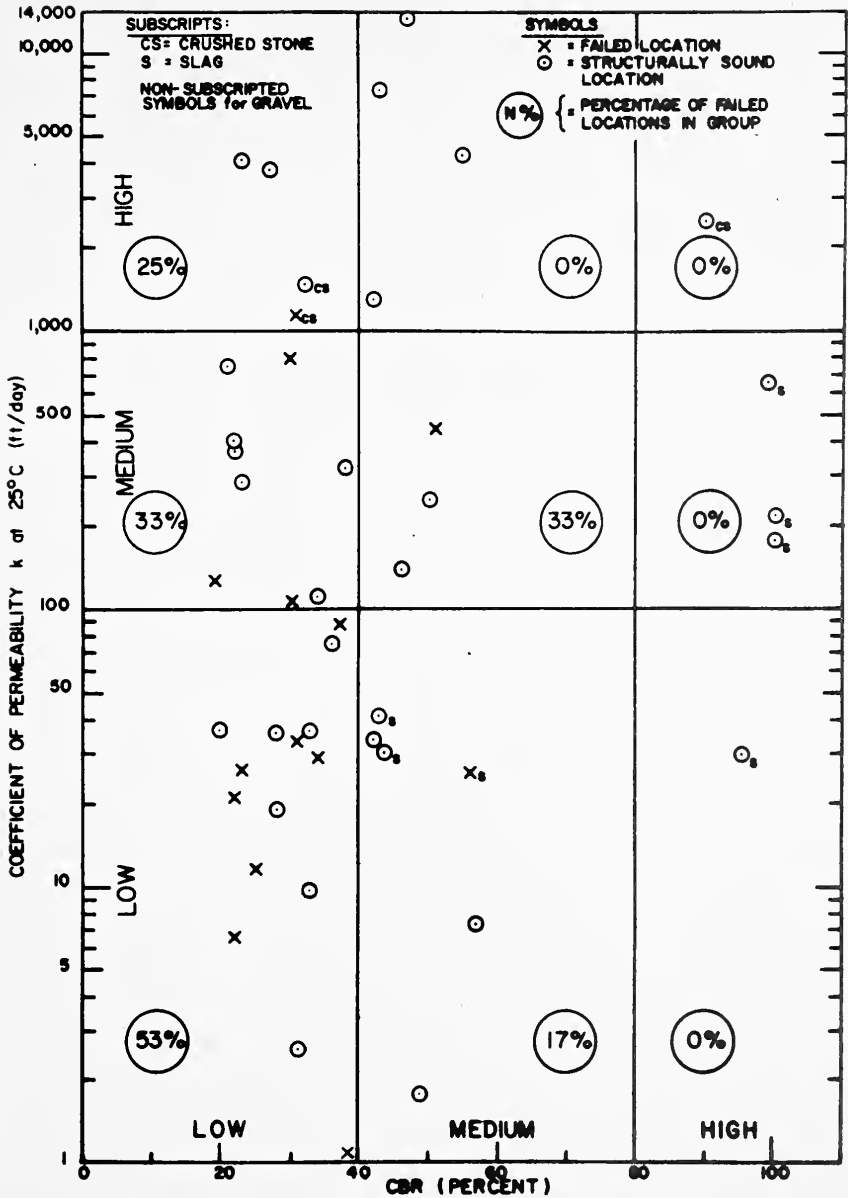

FIG.5 EFFECT OF SUBBASE STRENGTH AND PERMEABILITY ON CRCP PERFORMANCE

NOTES

CURVE NO.	HWY.	CONTRACT	STATIONS
①	I-65	R-7677	976+00 - 985+00 EBL
②	I-65	R-7677	976+00 - 985+00-NBL
③	I-65	R-7913	731+00 - 760+00 SBL

- ...-○ TEST SECTION WITHOUT FAILURES
- X---X TEST SECTION WITH FAILURES
- NO FAILURES ON ENTIRE CONTRACT

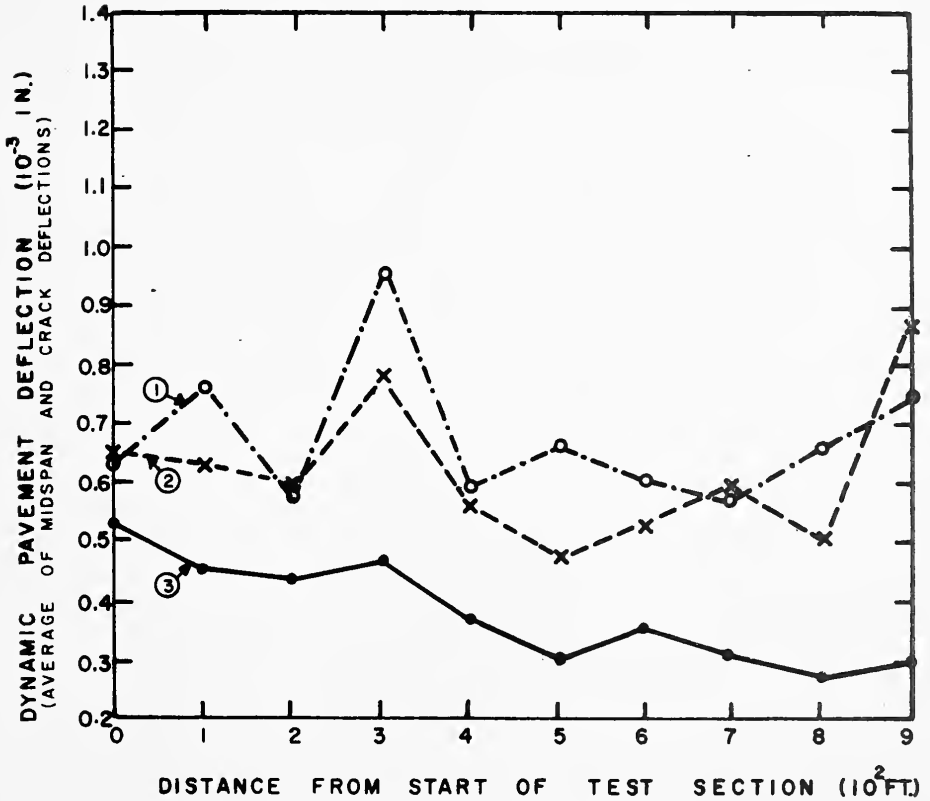

FIG. 6 DEFLECTION PROFILES OF TEST SECTIONS WITH GRAVEL SUBBASE.

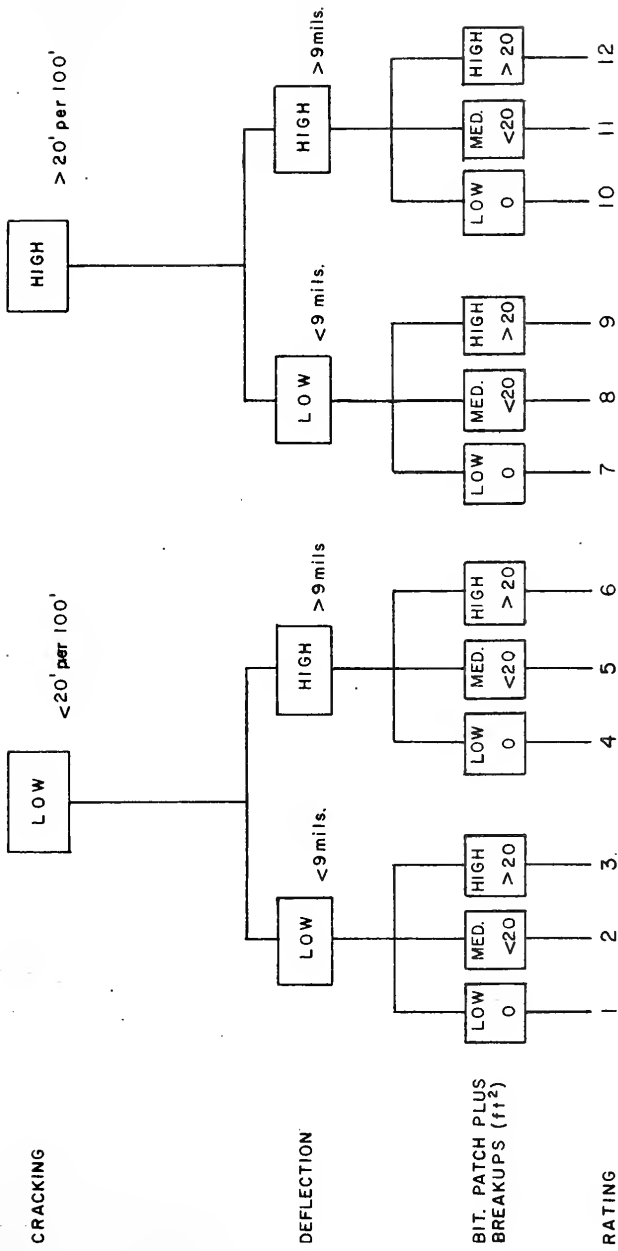

FIG. 7 RATING OF TEST SECTIONS

COVER DESIGN BY ALDO GIORGINI