



HAROLD B. LEE LIBRARY  
BRIGHAM YOUNG UNIVERSITY  
PROVO, UTAH





Digitized by the Internet Archive  
in 2011 with funding from  
Brigham Young University



Z  
250  
.A85x



Handy  
Specimen  
Book

**S**pecimens of Type  
Borders & Ornaments  
Brass Rules and Cuts, etc.



Catalogue of Printing Machinery  
and Materials, Wood Goods, etc.



... American ...  
**Type Founders Company**

Everything for the Printer  
1897

# FIVE AWARDS



COLUMBIAN EXPOSITION

CHICAGO, 1893

**HAROLD B. LEE LIBRARY**  
BRIGHAM YOUNG UNIVERSITY  
PROVO UTAH





## PREFACE



THE Type and Borders shown in this specimen book excel in design—the chief merit of type—and their durability is assured by the use of the celebrated Copper Alloy Type Metal.

A printing office completely supplied with the products of this Company is worth far more for either use or sale than one made up from the productions of incomplete type foundries.

It is conceded that the Type made by this Company is the standard for excellence throughout the world. Every endeavor is made to advance that standard.

As the largest purchaser of Printing Machinery and Materials in the world, this Company commands the best of everything for the printer, and has unsurpassed facilities for meeting the requirements of printing offices.

AMERICAN TYPE  
FOUNDERS COMPANY

A. D. 1897.

# AMERICAN TYPE FOUNDERS COMPANY

## BRANCHES \_\_\_\_\_

CHICAGO, 139-141 Monroe Street  
MINNEAPOLIS, 24-26 First Street, South  
DENVER, 1616-1622 Blake Street  
CLEVELAND, St. Clair and Ontario Streets  
CINCINNATI, 7-13 Longworth Street  
ST. LOUIS, Fourth and Elm Streets  
KANSAS CITY, 533-535 Delaware Street  
PORTLAND, Second and Stark Streets  
SAN FRANCISCO, 405-407 Sansome Street  
BOSTON, 150 Congress Street  
NEW YORK, Rose and Duane Streets  
PHILADELPHIA, 606-614 Sansom Street  
BALTIMORE, Frederick and Water Streets  
BUFFALO, 83-85 Ellicott Street  
PITTSBURGH, 323 Third Avenue



# INDEX TO TYPE SPECIMENS

	PAGE
ADVERTISING RULES . . . . .	41
Alaskan . . . . .	424, 425
Algebraic Signs . . . . .	640
Alpine . . . . .	494
American Old Style . . . . .	384, 385
American Point System . . . . .	22
Anglo Saxon No. 20 . . . . .	589
Angular Quads . . . . .	45
Antique No. 124 . . . . .	210, 211
Antique No. 125 . . . . .	212, 213
Antique No. 126 . . . . .	214, 215
Antique No. 127 . . . . .	205
Antique Condensed . . . . .	217-219
Antique Condensed No. 123 . . . . .	222, 223
Antique Condensed No. 124 . . . . .	224, 225
Antique Extra Cond. No. 150 . . . . .	220, 221
Antique Extended No. 120 . . . . .	234
Antique Extended No. 122 . . . . .	232
Antique Extended No. 123 . . . . .	232
Antique Extended No. 124 . . . . .	235
Antique Extended No. 152 . . . . .	233
Antique Extended No. 153 . . . . .	233
Antique Pointed No. 120 . . . . .	245
Apollo . . . . .	535
Arboret No. 2 . . . . .	463
Archaic . . . . .	445
Argent . . . . .	463
Arithmetical Signs . . . . .	642
Armenian . . . . .	57
Art Gothic . . . . .	442
Astronomical Signs . . . . .	638, 639
Atlanta . . . . .	420, 421
Augustan Text . . . . .	590
Auxiliaries . . . . .	662, 663
<b>BALLET DANCERS . . . . .</b>	<b>707</b>
Base Ball Cuts . . . . .	707
Billhead Logotypes . . . . .	715
Black Fists . . . . .	646
Boldface . . . . .	178
Boldface Celtic . . . . .	270
Boldface No. 120 . . . . .	179
Boldface Italic No. 120 . . . . .	180
Boston Black . . . . .	590
Bowlers . . . . .	709
Braces . . . . .	391, 651
Bradley . . . . .	522, 523
Bradley Initials . . . . .	523
Brass Braces . . . . .	39
Brass Circles and Ovals . . . . .	36, 37
Brass Column Rules . . . . .	40
Brass Curves and Clamps . . . . .	41
Brass Dashes . . . . .	38, 39
Brass Dash Rules . . . . .	41
Brass Head Rules . . . . .	40

	PAGE
Brass Leaders . . . . .	42
Brass Leads and Slugs . . . . .	42
Brass Rules, Strips . . . . .	25-31
Brass Scoring Rules . . . . .	42
Brass Space Rules . . . . .	42
Brass Type . . . . .	24
Breton . . . . .	226, 227
Broadgauge . . . . .	256

## Borders :—

Art . . . . .	684-688
Barta . . . . .	698, 699
Caxton . . . . .	668
Collins . . . . .	675
Combination . . . . .	690, 691
Daisy . . . . .	683
Darling . . . . .	683
Eighteen Point . . . . .	689
Elzevir . . . . .	668
Empire . . . . .	678, 679
Flame . . . . .	681
Florentine . . . . .	676, 677
Half Nonpareil . . . . .	700
Laurel . . . . .	680
Newspaper . . . . .	692-697
Nonpareil . . . . .	701
Pica . . . . .	702
Pointer . . . . .	683
Polka Dot . . . . .	682
Rococo . . . . .	667
Rustic Band . . . . .	682
Twelve Point . . . . .	689
Twenty-four Point . . . . .	689
Twinkler . . . . .	658
Wood . . . . .	768

<b>CALENDARS . . . . .</b>	<b>652-655</b>
Campaigners . . . . .	710
Cancelled Figures . . . . .	635
Card Pips and Indicators . . . . .	649
Caslon Old Style . . . . .	123-127
Caslon Old Style Italic . . . . .	128
Caslon Condensed . . . . .	386
Caxton Black . . . . .	585
Caxton Bold . . . . .	158, 159
Caxton Old Style . . . . .	113, 136, 137
Caxton Old Style Italic . . . . .	138
Central Antique . . . . .	206, 207
Chamfer Condensed . . . . .	286, 287
Check and Bill Blanks . . . . .	716, 717
Chelsea Circular . . . . .	536
Chessmen and Checkers . . . . .	648
Chinese . . . . .	494
Circular Gothic No. 120 . . . . .	543
Circular Italic No. 120 . . . . .	579

## INDEX TO TYPE SPECIMENS

	PAGE		PAGE
Circular Quads . . . . .	45	Egyptian Extended . . . . .	238
Clarendon No. 120 . . . . .	228, 229	Egyptian Extra Cond. No. 120 . . . . .	242, 243
Clarendon Condensed . . . . .	231	Elandkay . . . . .	486
Clarendon Condensed No. 122 . . . . .	230	Elberon No. 2 . . . . .	440
Collins Bands . . . . .	672-674	Election Signs . . . . .	643
Collins Florets . . . . .	670, 671	Electrotyped Date Lines . . . . .	712, 713
Columbian . . . . .	447	Electrotyped Outline Figures . . . . .	752
Columbian Medals . . . . .	751	Electrotyped Take Slugs . . . . .	43
Columbus No. 2 . . . . .	376-378	Elzevir Bands . . . . .	668
Columbus Initials . . . . .	376, 377	Elzevir Florets . . . . .	669
Columbus Outline . . . . .	374, 375	Elzevir Gothic . . . . .	453
Columbus Outline Initials . . . . .	374, 375	End-Wood Borders . . . . .	768
Combination Condensed Gothic . . . . .	274	Engraving Blanks . . . . .	644
Combination Gothic . . . . .	275, 280	Epitaph and Epitaph Open . . . . .	398, 399
Combination Italic Gothic . . . . .	341	Erebus . . . . .	456
Commercial Logotypes . . . . .	714	Erratick and Erratick Outline . . . . .	392, 393
Commercial Signs . . . . .	640	Euclid . . . . .	492, 493
Concave No. 120 . . . . .	258, 259	Extra Condensed . . . . .	182-184
Concave Condensed No. 120 . . . . .	260, 261		
Concave Extended No. 120 . . . . .	257	FACADE . . . . .	476, 477
Condensed . . . . .	170, 171	Facade Condensed . . . . .	478, 479
Condensed Aldine No. 150 . . . . .	190, 191	Facade Condensed No. 2 . . . . .	480, 481
Condensed Title . . . . .	186	Fancy Grotesque . . . . .	541
Condensed Title No. 104 . . . . .	192	Ferdinand . . . . .	430
Condensed Title No. 123 . . . . .	188, 189	Fillet . . . . .	458
Condensed Title No. 124 . . . . .	185	Fine-Dot Leaders . . . . .	580, 650
Condensed Title No. 125 . . . . .	187	Fists . . . . .	646
Contour No. 1 . . . . .	402, 403	Five-Pointed Stars . . . . .	647
Contour No. 2 . . . . .	400	Florentine Old Style No. 2 . . . . .	504-506
Contour No. 3 . . . . .	409	Foster Gothic . . . . .	450
Contour No. 4 . . . . .	406, 407	Foster Gothic Extended . . . . .	451
Contour No. 5 . . . . .	401	Foster Gothic Extended No. 2 . . . . .	452
Contour No. 6 . . . . .	404, 405	French Antique No. 110 . . . . .	239
Contour No. 7 . . . . .	408	French Clarendon No. 120 . . . . .	240, 241
Copper Alloy Fine-Dot Leaders . . . . .	580, 650	French Clarendon Ex. No. 120 . . . . .	236, 237
Copper Alloy Imprints . . . . .	273, 650	French Elzevir No. 1 . . . . .	120
Copper Alloy Take Slugs . . . . .	43	French Old Style No. 1 . . . . .	142, 143
Coppers . . . . .	705	French Old Style No. 2 . . . . .	130-134
Corner Quads . . . . .	45	French Old Style No. 2 Italic . . . . .	135
Crayon . . . . .	464	French Old Style Extended . . . . .	168, 169
Cushing . . . . .	112, 532	Full Face No. 123 . . . . .	194, 195
Cushing Italic . . . . .	533	Full Face Italic No. 123 . . . . .	193
Cushing Old Style . . . . .	160, 161		
		<b>Fractions:—</b>	
DASHES . . . . .	38, 39, 651	Caledonian . . . . .	636
Date Lines . . . . .	712, 713	DeVine . . . . .	637
De Vinne . . . . .	354-356	Doric . . . . .	637
De Vinne Condensed . . . . .	357-359	Gothic . . . . .	637
De Vinne Extra Condensed . . . . .	360-362	Gothic Condensed . . . . .	637
De Vinne Extended . . . . .	352, 353	Piece . . . . .	77, 634, 635
De Vinne Italic . . . . .	363-365	Poster Roman . . . . .	636, 637
De Vinne Italic Outline . . . . .	366, 367	Self Spacing Piece . . . . .	77, 634
De Vinne Shaded . . . . .	368, 369	Special . . . . .	636
Delmonicos . . . . .	708		
Domestics . . . . .	708	GOTH . . . . .	487
Doric No. 120 . . . . .	246, 247	Gothic No. 122 . . . . .	304, 305
Doric Italic . . . . .	346, 347	Gothic No. 124 . . . . .	300, 301
Douglas . . . . .	426	Gothic No. 127 . . . . .	276, 277
Duerer . . . . .	416, 417	Gothic No. 1510 . . . . .	281
Dynamo . . . . .	444	Gothic Condensed No. 112 . . . . .	274
		Gothic Condensed No. 122 . . . . .	288, 289
EASTMAN . . . . .	380, 381	Gothic Condensed No. 123 . . . . .	292, 293
Eccentric . . . . .	449	Gothic Condensed No. 124 . . . . .	294, 295
Edinburgh Title . . . . .	146	Gothic Condensed No. 127 . . . . .	282, 283

# INDEX TO TYPE SPECIMENS

	PAGE
Gothic Condensed No. 128 . . . . .	284, 285
Gothic Condensed No. 129 . . . . .	290, 291
Gothic Extra Cond. No. 122 . . . . .	296, 297
Gothic Extra Cond. No. 150 . . . . .	298
Gothic Italic . . . . .	344, 345
Gothic Italic No. 124 . . . . .	340
Gothic Italic Extra Cond. . . . .	342, 343
Gothic No. 125 . . . . .	302, 303
Gothic Slope No. 20 . . . . .	339
Gothic Wide . . . . .	337
Gothic Wide No. 2 . . . . .	338
Greek . . . . .	51-53
Grimaldi . . . . .	488
Grolier . . . . .	545
Grotesque No. 12c . . . . .	540
Gutenberg . . . . .	489

## German:—

Composite No. 150 . . . . .	627
Cond. German Black No. 150 . . . . .	623
Full Face . . . . .	622
Germania No. 150 . . . . .	628
German Self Spacing . . . . .	78, 79
Heintzemann . . . . .	629
Ihlenburg . . . . .	626
Plain Faces . . . . .	610-617
Poster German No. 121 . . . . .	613
Schwabacher . . . . .	624
Schwabacher No. 2 . . . . .	625
Teutonic No. 150 . . . . .	623
Title No. 122 . . . . .	620, 621
Title Condensed No. 150 . . . . .	618, 619

HADES . . . . .	457
Half Title . . . . .	174
Half-tone . . . . .	467
Happy Thoughts . . . . .	666
Hardware . . . . .	255
Harvard Italic . . . . .	530, 531
Heavyface Greek . . . . .	53
Hebrew . . . . .	54-56
Hermes . . . . .	469
Houghton . . . . .	431
Howland . . . . .	370, 371
Howland Open . . . . .	372, 373

IMPRINTS—COPPER ALLOY . . . . .	273, 650
Imprint Gothic . . . . .	273
Inclined Gothic . . . . .	348
Inclined Program . . . . .	542
Index Corners . . . . .	750
Index Cuts . . . . .	646
Inferior Letters and Figures . . . . .	635
Ink Spots . . . . .	711
Inscription Greek . . . . .	53
Insects . . . . .	711
Interchangeable Gothic . . . . .	278, 279
Ionic . . . . .	200, 201, 204
Ionic No. 150 . . . . .	202, 203
Iroquois . . . . .	434
Iroquois Condensed . . . . .	435
Isabella . . . . .	537
Ivanhoe . . . . .	500, 501
Ivy . . . . .	538

## Initials:—

	PAGE
Acorn . . . . .	632
Art . . . . .	631
Bradley . . . . .	523
Columbus . . . . .	376, 377
Columbus Outline . . . . .	374, 375
Electrotyped . . . . .	632, 633
Index . . . . .	633
Jenson . . . . .	517
Morris . . . . .	517
Mortised No. 2 . . . . .	631
Ornamental Cast . . . . .	630, 631
Renate . . . . .	633
Sphinx . . . . .	633
Waverley . . . . .	632

JAGGED . . . . .	484
Jefferson . . . . .	412, 413
Jenson Embellishments . . . . .	507-509, 518
Jenson Initials . . . . .	517
Jenson Italic . . . . .	519-521
Jenson Old Style . . . . .	507-516
Johnson . . . . .	443
Johnson Gothic . . . . .	299

KOSTER . . . . .	441
------------------	-----

LABOR-SAVING BRASS LEADERS . . . . .	42
Labor-Saving Brass Rule . . . . .	32-35
Labor-Saving Leads and Slugs . . . . .	43
Labor-Saving Quotation Furniture . . . . .	44
Lafayette . . . . .	414, 415
Latin No. 20 . . . . .	267
Latin Antique No. 120 . . . . .	162, 163
Latin Condensed No. 150 . . . . .	248, 249
Latin Extended . . . . .	254
Law Italic . . . . .	580, 581
Leads and Slugs . . . . .	42, 43
Lightface No. 158 . . . . .	176
Lightface Celtic No. 150 . . . . .	268, 269
Lightface Celtic Cond. No. 120 . . . . .	272
Light Runic . . . . .	266
Lincoln . . . . .	427
Lining Antique . . . . .	208, 209
Lining Gothic No. 43 . . . . .	312, 313
Lining Gothic No. 44 . . . . .	314, 315
Lining Gothic No. 45 . . . . .	316, 317
Lining Gothic Extended No. 40 . . . . .	336
Lippincott . . . . .	382, 383
Listeners . . . . .	704
Litho . . . . .	560
Lithotint . . . . .	466
Livermore . . . . .	528, 529
Livermore Outline . . . . .	527
Locus Sigilli . . . . .	644
Logotypes . . . . .	636
Longfellow . . . . .	496, 497
Luray . . . . .	462

MAIL LIST LOGOTYPES . . . . .	63
Mail List Type . . . . .	62, 63
Maltese Crosses . . . . .	647
Mansfield . . . . .	429
McCullagh . . . . .	432, 433

## INDEX TO TYPE SPECIMENS

	PAGE		PAGE
Medical Signs . . . . .	640	Philadelphia Lining Gothic . . . . .	318-335
Metal Braces . . . . .	651	Pick-Ups . . . . .	709
Metal Furniture . . . . .	44	Piece Accents . . . . .	639
Mid Gothic . . . . .	308-310	Piece Fractions . . . . .	77, 634, 635
Miscellaneous Cast Cuts . . . . .	718, 719	Piece Root Signs . . . . .	642
Miscellaneous Cuts . . . . .	741-751	Pin, Nail and Screw Heads . . . . .	651
Miscellaneous Signs . . . . .	641, 642	Pluto . . . . .	439
Modern Antique . . . . .	250-252	Pointers . . . . .	656
Modern Antique Wide No. 110 . . . . .	253	Porson Greek . . . . .	51, 52
Morning Glory . . . . .	488	Poster Antique No. 125 . . . . .	604, 605
Morris Initials . . . . .	517	Poster Commercial . . . . .	498, 499
Mortised . . . . .	390, 391	Poster De Vinne . . . . .	596-598
Multiform . . . . .	454, 455	Poster De Vinne Condensed . . . . .	599-601
Mural . . . . .	474, 475	Poster Ionic . . . . .	606, 607
Music Type . . . . .	46-50	Poster Latin Antique No. 120 . . . . .	602, 603
NEWFANGLE . . . . .	448	Poster Lightface No. 158 . . . . .	608, 609
Newspaper Headings . . . . .	721-725	Poster Old Style Ant. No. 120 . . . . .	594, 595
Newspaper Subheadings . . . . .	720	Poster Roman No. 4 . . . . .	99
New Tuscan No. 120 . . . . .	244	Poster Roman No. 120 . . . . .	98, 99
Norman Condensed . . . . .	487	Poster Roman No. 123 . . . . .	100, 101
OLD STYLE No. 43 . . . . .	144	Priory Text . . . . .	588
Old Style No. 83 . . . . .	139	Program . . . . .	539
Old Style Italic No. 83 . . . . .	140, 141	QUAINT AND QUAINT OPEN . . . . .	396, 397
Old Style Antique . . . . .	164, 165	Quaint Gothic . . . . .	389
Old Style Antique No. 112 . . . . .	166	Quaint Roman No. 2 . . . . .	388
Old Style Bold . . . . .	167	Quentell . . . . .	349-351
Old Style Condensed No. 4 . . . . .	152	RABBINIC . . . . .	57
Old Style Condensed No. 40 . . . . .	147	Ramona . . . . .	490
Old Style Condensed No. 120 . . . . .	148, 149	Raphael . . . . .	465
Old Style Condensed No. 122 . . . . .	150, 151	Recipe Marks . . . . .	644
Old Style Extended . . . . .	154, 155	Rembrandt . . . . .	468
Old Style Latin Cond. No. 30 . . . . .	153	Reversible Metal Furniture . . . . .	44
Old Style Two-Line . . . . .	145	Rigs and Traps . . . . .	705
Open Title No. 120 . . . . .	181	Rimpled . . . . .	379
Outing . . . . .	485	Rivet . . . . .	449
Outline Figures . . . . .	752	Romanesque . . . . .	271
Oxford No. 2 . . . . .	495	Roman Extended No. 120 . . . . .	196, 197
<b>Ornaments:—</b>		<b>Roman and Italic, Modern:—</b>	
Apple Blossom . . . . .	664	American Press Association . . . . .	88
Auxiliaries . . . . .	662, 663	Century Roman . . . . .	102
Central . . . . .	659-661	Plain Faces . . . . .	80-102
Christmas . . . . .	703	Poster Roman No. 120 . . . . .	98, 99
Combination . . . . .	667	Poster Roman No. 123 . . . . .	100, 101
Margin . . . . .	665	Self Spacing . . . . .	68-71
Mural . . . . .	703	<b>Roman and Italic, Old Style:—</b>	
Nick Nacks . . . . .	658	Caslon Old Style . . . . .	123-127
Palmetto . . . . .	657	Caslon Old Style Italic . . . . .	128
Rule . . . . .	659	Caxton Old Style . . . . .	113
Scroll Corner . . . . .	665	Caxton Old Style Italic . . . . .	138
Stellar . . . . .	661	Cushing . . . . .	112
Turner . . . . .	661	French Elzevir No. 1 . . . . .	129
Twinklers . . . . .	658	French Old Style No. 1 . . . . .	142, 143
Word . . . . .	667	French Old Style No. 2 . . . . .	130-134
French Old Style No. 2 Italic . . . . .	135	Old Style Plain Faces . . . . .	103-111
PALO ALTO . . . . .	491	Ronaldson . . . . .	114-117
Parisian Black No. 120 . . . . .	592	Self Spacing . . . . .	72-74
Parthenian . . . . .	156, 157	Self Spacing Italic . . . . .	75
Pencilings . . . . .	490	Ronaldson Clarendon . . . . .	120
Pen Text . . . . .	552, 553	Ronaldson Condensed . . . . .	118
Perforating Rules . . . . .	42		
Perpetual Logotype Calendars. . . . .	652, 653		

# INDEX TO TYPE SPECIMENS

	PAGE		PAGE
Ronaldson Extended . . . . .	119	Special Logotypes . . . . .	636
Ronaldson Gothic . . . . .	122	Star Rule . . . . .	767
Ronaldson Old Style . . . . .	114, 117	Stars . . . . .	647
Ronaldson Title Slope . . . . .	121	State Seals . . . . .	726, 727
Royal Gothic . . . . .	306, 307	Steel Cutting Rules . . . . .	42
Rubens . . . . .	418, 419	Steelplate Gothic . . . . .	460
Runic Condensed No. 120 . . . . .	262, 263	Stipple . . . . .	459
Runic Condensed No. 122 . . . . .	264, 265	Stylus . . . . .	554, 555
Russian No. 10 . . . . .	57	Superior Letters and Figures . . . . .	635
		Synopsis of Roman Faces . . . . .	58-61
SAMOA . . . . .	387	TABLE FIGURES . . . . .	64, 65
Santa Cruz . . . . .	491	Take Slugs . . . . .	43
Satanick . . . . .	524-526	Taylor Gothic . . . . .	311
<b>Scripts:—</b>		Telescopic Gothic . . . . .	273
Alfereta . . . . .	558	Time-Saving Mail List Type . . . . .	62, 63
Autograph . . . . .	560	Time-Table Figures . . . . .	64, 65
Boston . . . . .	572, 573	Title Black . . . . .	591
Carpenter . . . . .	561	Title Expanded No. 120 . . . . .	198, 199
Chicago . . . . .	556	Trinal . . . . .	436-438
Circular . . . . .	550	Tristan Italic . . . . .	544
Cleveland . . . . .	561	Tudor Black . . . . .	586, 587
French . . . . .	546, 547	Two-Line Letter . . . . .	172, 173
Hoyt . . . . .	561	Two-Line No. 151 . . . . .	175
Ladies' Hand . . . . .	574, 575	Type Standards . . . . .	22
Magnolia . . . . .	560	Typo . . . . .	428
Manuscript . . . . .	551	 <b>Type-Writer:—</b>	
Master . . . . .	549	Caligraph . . . . .	582
Novelty . . . . .	577	Earle . . . . .	584
Old Style . . . . .	562, 563	Fourteen Point No. 2 . . . . .	584
Quincy . . . . .	559	Remington Standard . . . . .	582
Royal . . . . .	564-566	Smith-Premier . . . . .	583
Shepard . . . . .	548	Ten Point No. 2 . . . . .	584
Skinner . . . . .	559	Twelve Point . . . . .	583
Spencerian . . . . .	568, 569	Yost . . . . .	582
Spencerian No. 2 . . . . .	567	 	
Spinner . . . . .	557	UNIQUE CELTIC . . . . .	472
Steelplate . . . . .	570, 571	Unique Celtic Condensed . . . . .	470, 471
Title . . . . .	576	United States Emblems . . . . .	728
Scorchers . . . . .	706	United States Signal Flags . . . . .	645
Sectional Logotype Calendars . . . . .	654, 655	University . . . . .	177
Self Spacing Type—Description of . . . . .	66, 67	 	
Self Spacing German . . . . .	78, 79	VENUS . . . . .	465
Self Spacing Modern Roman . . . . .	68-71	Venetian . . . . .	578
Self Spacing Old Style . . . . .	72-74	Victoria . . . . .	422, 423
Self Spacing Old Style Bold . . . . .	76	Victoria Italic . . . . .	482, 483
Self Spacing Old Style Italic . . . . .	75	Virile and Virile Open . . . . .	394, 395
Self Spacing Piece Fractions . . . . .	77, 634	 	
Shadow . . . . .	461	WALTON . . . . .	446
Shaved Leads and Slugs . . . . .	43	Washington . . . . .	410, 411
Signet . . . . .	489	Waverly Circular . . . . .	534
Signet Shade . . . . .	468	Weather Indicators . . . . .	645
Silhouettes . . . . .	710	Webster . . . . .	473
Skeleton Antique No. 122 . . . . .	216	Whist Markers . . . . .	649
Skjald . . . . .	502, 503	Whiteface Figures . . . . .	64, 65
Slocum Seals . . . . .	711	Wood Rule . . . . .	767
Society Emblems . . . . .	730-741	Wood Type . . . . .	753-766
Speakers . . . . .	704	 	
Special Figures . . . . .	636	YONKERS . . . . .	593
Special Fractions . . . . .	636		

# INDEX TO CUTS

	PAGE			PAGE
Bill Blanks . . . . .	716, 717	Ice Wagons . . . . .	744, 745	
Billhead Logotypes . . . . .	715	Index Corners . . . . .	750	
Bill of Fare . . . . .	749	Locomotives . . . . .	743	
Blank Books . . . . .	718, 744	Maltese Crosses . . . . .	647	
Buffalo . . . . .	742, 746	Masquerade . . . . .	719	
Carriages . . . . .	718, 719, 745	Menu . . . . .	749	
Cattle, Sheep, etc. . . . .	718, 719, 742, 746	Newspaper . . . . .	718, 719	
Check Blanks . . . . .	716, 717	Opticians' . . . . .	718	
Coal Carts . . . . .	744, 745	Outline News Cuts . . . . .	748	
Columbian Medals . . . . .	751	Political . . . . .	746, 747	
Commercial Logotypes . . . . .	714	Portraits . . . . .	729	
Dentists' . . . . .	718, 744	Poultry . . . . .	718, 719, 746, 747	
Druggists' . . . . .	718, 744, 746	Society Emblems . . . . .	718, 730, 741	
Eagles . . . . .	728, 747	Stars . . . . .	647	
Fists . . . . .	646	State Seals . . . . .	726-728	
Flags . . . . .	718, 728	Steamboats . . . . .	718, 719, 742, 743	
Funeral . . . . .	744	Telephone . . . . .	745	
Horse Racing . . . . .	719, 742, 746	Trolley Car . . . . .	743	
Horses . . . . .	719, 742, 746	Wine List . . . . .	749	

NO.	PAGE	PRICE	NO.	PAGE	PRICE	NO.	PAGE	PRICE
234A . . . . .	740	\$.40	3147A . . . . .	736	\$.50	190B . . . . .	736	\$1.25
987A . . . . .	740	.60	3149A . . . . .	739	.75	191B . . . . .	735	.50
1850A . . . . .	732	.40	3152A . . . . .	735	1.00	193B . . . . .	741	.45
2079A . . . . .	733	.50	3154A . . . . .	738	1.00	195B . . . . .	741	.75
2319 1/2 A . . . . .	737	.75	3161A . . . . .	740	.75	197B . . . . .	741	.60
2601A . . . . .	736	.65	3167A . . . . .	738	1.00	198B . . . . .	741	.60
2820A . . . . .	737	.50	3168A . . . . .	737	.60	202B . . . . .	741	.75
3024A . . . . .	735	.30	3171A . . . . .	737	1.00	203B . . . . .	738	1.00
3027A . . . . .	732	.30	3172A . . . . .	740	.50	204B . . . . .	739	.90
3044A . . . . .	733	.75	3174A . . . . .	741	.60	205B . . . . .	739	.75
3059A . . . . .	732	.75	3185A . . . . .	735	1.00	206B . . . . .	739	.60
3066A . . . . .	732	.75	3186A . . . . .	737	1.00	207B . . . . .	738	.90
3077A . . . . .	732	.40	3189A . . . . .	738	.50	208B . . . . .	740	.40
3078A . . . . .	732	.75	3191A . . . . .	735	.75	209B . . . . .	740	.50
3079A . . . . .	732	1.00	3196A . . . . .	740	1.25	211B . . . . .	739	.75
3083A . . . . .	732	1.00	3198A . . . . .	740	1.00	214B . . . . .	730	.60
3089A . . . . .	737	.75	3323A . . . . .	733	.60	215B . . . . .	731	.75
3099A . . . . .	734	.30	3327A . . . . .	732	.75	216B . . . . .	730	.90
3109A . . . . .	733	.35	162B . . . . .	729	1.25	217B . . . . .	730	.35
3110A . . . . .	735	.40	165B . . . . .	733	.30	220B . . . . .	731	.35
3118A . . . . .	735	.75	166B . . . . .	733	.30	221B . . . . .	731	.40
3119A . . . . .	734	.75	168B . . . . .	732	.75	222B . . . . .	730	.40
3121A . . . . .	734	1.00	170B . . . . .	733	.40	223B . . . . .	731	.50
3122A . . . . .	734	1.00	172B . . . . .	733	.25	224B . . . . .	731	.60
3123A . . . . .	734	1.00	173B . . . . .	735	.25	225B . . . . .	731	.60
3126A . . . . .	736	.60	174B . . . . .	734	1.00	227B . . . . .	730	.50
3129A . . . . .	737	.60	175B . . . . .	734	1.00	228B . . . . .	731	.75
3133A . . . . .	737	.60	176B . . . . .	734	1.00	229B . . . . .	730	.50
3136A . . . . .	737	.60	177B . . . . .	735	.35	232B . . . . .	731	.60
3141A . . . . .	739	.50	180B . . . . .	733	.30	233B . . . . .	731	.50
3142A . . . . .	739	.50	181B . . . . .	735	.60	234B . . . . .	731	.75
3143A . . . . .	739	.60	184B . . . . .	736	.90	235B . . . . .	730	.40
3144A . . . . .	739	.60	185B . . . . .	735	1.00	237B . . . . .	730	.70
3146A . . . . .	738	.60				238B . . . . .	731	.75



# INDEX TO CUTS

NO.	PAGE	PRICE	NO.	PAGE	PRICE	NO.	PAGE	PRICE
239B	730	\$.90	2356C	744	\$.50	3993C	750	\$.25
240B	731	.40	2389C	728	1.00	3995C	746	.60
241B	730	.40	2425C	744	.40	3996C	736	.75
242B	730	.40	2431C	733	1.00	4043C	750	.35
243B	730	.40	2432C	733	.50	4044C	750	.35
245B	730	.35	2443C	728	.30	4047C	750	.50
247B	737	.50	2450C	729	.37	4048C	750	.50
250B	739	.50	2466C	746	.50	4049C	750	.50
251B	738	.50	2470C	745	.75	4050C	750	.50
252B	738	.50	2471C	728	.50	4051C	750	.50
254B	736	1.00	2678C	744	.75	4052C	750	.50
256B	740	.75	2695C	744	.75	4053C	750	.50
257B	738	.60	2708C	729	1.50	4055C	749	.50
260B	738	.75	2726C	747	.25	4058C	749	.75
262B	739	.75	2752C	728	.75	4065C	749	.75
267B	736	.75	2781C	726	.75	4067C	749	.60
268B	739	1.15	2791C	726	.75	4068C	749	.75
272B	745	.35	2796C	726	.75	4070C	749	.60
273B	745	.45	2797C	726	.75	4092C	745	.75
275B	745	.50	2807C	743	1.00	4099C	747	1.00
276B	744	.50	2898C	745	1.25	4120C	743	.75
277B	744	.35	2904C	729	.50	4123C	733	.75
278B	730	.40	2929C	747	1.00	4125C	741	.40
			2970C	734	.50	4127C	744	.75
92C	715	.30	3023C	728	.25	4140C	732	1.00
93C	715	.35	3055C	747	.40	4141C	729	.75
94C	715	.40	3062C	742	.30	4148C	729	.40
95C	715	.40	3125C	727	1.00	4153C	730	.30
96C	715	.40	3126C	727	1.00	4167C	743	.40
97C	715	.40	3127C	727	1.00	4168C	743	.60
98C	715	.35	3128C	727	1.00	4175C	751	
99C	715	.35	3131C	727	1.00		per set, 2.50	
100C	715	.40	3140C	727	1.00	4176C	751	
101C	715	.40	3182C	728	.75		per set, 2.00	
102C	715	.40	3204C	746	.80	4178C	751	
103C	715	.40	3370C	742	.50		per set, 2.00	
104C	715	.40	3380C	744	1.00	4179C	751	
105C	715	.40	3399C	733	.50		per set, 1.00	
106C	715	.40	3400C	733	.50	4185C	739	.75
107C	715	.40	3401C	733	.50	4201C	748	.50
108C	715	.40	3402C	733	.50	4202C	748	.50
109C	715	.40	3403C	733	.50	4203C	748	.50
209C	717	.30	3404C	733	.50	4204C	748	.50
270C	717	.30	3418C	735	.60	4205C	748	.50
279C	716	.30	3419C	736	.75	4206C	748	.50
280C	716	.30	3436C	746	.60	4207C	748	.50
295C	717	.40	3452C	742	.30	4208C	748	.50
296C	717	.40	3471C	745	.75	4209C	748	.50
297C	717	.40	3653C	732	.35	4210C	748	.50
304C	717	.40	3657C	737	.40	4211C	748	.50
305C	717	.40	3658C	737	.35	4212C	748	.50
319C	717	.50	3659C	739	.40			
320C	717	.50	3661C	735	.30	1629D	742	.75
321C	716	.40	3701C	726	1.50	1873D	740	.60
322C	716	.40	3756C	746	1.25	1874D	740	.75
323C	716	.75	3787C	746	1.25	2253D	744	.80
323½C	716	.75	3800C	746	.30			
328C	716	.75	3818C	729	1.00	1E	718	.08
328½C	716	.75	3953C	741	.75	3E	718	.08
329C	716	.40	3955C	741	.60	117E	718	.12
330C	716	.30	3972C	735	.60	123E	718	.15
2035C	747	.50	3990C	750	.25	124E	718	.15
2171C	744	.50	3991C	750	.25	125E	718	.15
2213½C	728	1.50	3992C	750	.25	255E	719	.12

## INDEX TO CUTS

NO.	PAGE	PRICE	NO.	PAGE	PRICE	NO.	PAGE	PRICE
315E	718	\$.15	613E	718	\$.15	1116F	734	\$.40
322E	718	.15	615E	718	.20	2527F	718	.15
364E	718	.15	700E	718	.30	2544F	718	.15
409E	718	.08	701E	718	.20	2600F	718	.20
412E	718	.10	707E	718	.20	2657F	719	.20
416E	718	.10	709E	719	.25	2801F	718	.08
422E	718	.10	711E	719	.25	4021F	718	.25
423E	718	.12	717E	719	.25	4057F	719	.20
431E	718	.12	730E	719	.25	4060F	718	.20
432E	718, 733	.25	731E	719	.25	4062F	718	.20
433E	718	.12	732E	719	.25	4063F	718	.15
435E	718	.15	734E	718	.15	4064F	718	.20
436E	718	.20	735E	718	.15	4099F	719	.30
455E	718	.20	804E	719	.25	4100F	728	.25
465E	719	.15	857E	728	.30	4108F	718	.15
466E	718	.15	858E	719	.30	4115F	718	.30
468E	719	.20	865E	718	.30	4117F	719	.25
501E	718	.12	868E	718	.35	4118F	719	.25
502E	718	.12	917E	719	.30	4120F	719	.35
506E	718	.12	2022E	741	1.00	4121F	719	.30
511E	719	.15	2045E	744	.50	4122F	719	.30
514E	728	.25	2046E	747	1.00	4123F	719	.35
517E	718	.20	2050E	746	1.00	4124F	719	.30
526E	718	.20	2057E	742	1.00	4125F	719	.30
527E	718	.25	2058E	743	.90	4126F	719	.30
532E	718	.25	2060E	743	.90	4129F	718	.30
604E	718	.15	2068E	742	1.00	4131F	718	.30
612E	718	.30	2076E	742	.50	4149F	719	.30

### ELECTROTYPED CUTS

There is this advantage  
in purchasing electrotyped cuts  
from this Company: Nearly all  
its cuts are original, and electro-  
types are furnished from the  
original engravings. The great  
majority of the cuts shown in  
all specimen books were origi-  
nated by Branches of the

**American Type Founders  
Company**



# INDEX TO THE PRICE LIST OF PRINTING MACHINERY AND MATERIALS

**For the Composing Room, see pages . . . . . 771 to 829**  
**For the Press Room, see pages . . . . . 830 to 887**  
**For the Stock Room and Bindery, see pages . . . . . 888 to 927**  
**For the Mailing Department, see pages . . . . . 928 to 930**  
**Miscellaneous, see pages . . . . . 931 to 934**

	PAGE		PAGE
Adamson Disc Cover . . . . .	837	Card Cutters . . . . .	898, 899
Addressing Machines . . . . .	928-930	Cases . . . . .	800-805
Backing for Electrotypes . . . . .	934	Case Racks . . . . .	808, 817
Beating Tables . . . . .	793	Case Stands . . . . .	806-808
Bellows . . . . .	776	Case Stands, Wrought Iron . . . . .	809
Belting . . . . .	831	Chases . . . . .	790-793
Bentrovato . . . . .	847	Chesapeake Economy Compound . . . . .	846
Benzine Cans . . . . .	838	Composing Rules . . . . .	774
Blankets, Felt . . . . .	830	Composing Stick Rack . . . . .	775
Blankets, Rubber . . . . .	830	Composing Sticks . . . . .	772-774
Bodkins . . . . .	771	Copy Holder . . . . .	775
Book Sewing Machine, Tennis . . . . .	911	Counters . . . . .	836
Bookbinders' Shears . . . . .	898	Crown Engraving Plates . . . . .	932
Brackets . . . . .	821	Curving Machine . . . . .	781
Brass Type . . . . .	24	Cutting Boards, Bookbinders' . . . . .	927
Bronzing Machine, Emmerich . . . . .	887	Cutting and Creasing Press . . . . .	860
Bronzing Mitten . . . . .	837	Cutting Sticks . . . . .	897
Bronzing Pad . . . . .	837	Disc Cover, Adamson . . . . .	837
Brower Quoin Lock . . . . .	789	Drying Racks . . . . .	850, 851
Brushes, Benzine . . . . .	832	Economy Wrapper Paster . . . . .	930
—Liquid Cement . . . . .	832, 913	Elastic Padding Glue . . . . .	913
—Lye . . . . .	832	Embossing Composition . . . . .	847
—Proof . . . . .	832	Embossing Made Easy . . . . .	847
—Stereo, Beating . . . . .	832	Embossing Press, Hand . . . . .	918
Cabinets . . . . .	810-820	Embossing Press, Power . . . . .	919
—American-Polhemus . . . . .	814	Embossing Press, Universal . . . . .	859
—American Steel-Run . . . . .	811	Engravers' Tools . . . . .	824
—Bookbinders' . . . . .	819	Engravers' Wood . . . . .	824
—Combination No. 1 . . . . .	813	Engraving Plates . . . . .	932
—Eagle . . . . .	813	Eyeletting Machines . . . . .	916, 917
—Electro. and Cut . . . . .	818	Eyelet Punch and Set . . . . .	915
—Handy Sort . . . . .	820	Eyelets . . . . .	917
—Ink and Roller . . . . .	848	Eye Shade . . . . .	775
—Paper and Card Stock . . . . .	818	Eureka Type Wash . . . . .	846
—Porter's Extension Front . . . . .	812	Folders . . . . .	883-885
—Rowen Border and Script . . . . .	816	—Bennett Country Quarto . . . . .	885
—Specimen . . . . .	819	—Bennett Economical . . . . .	885
—Wisconsin Hard Wood . . . . .	810	—Tribune Newspaper . . . . .	883
—Wisconsin Window . . . . .	815	—Unique . . . . .	884
—Wood Type . . . . .	817		

## INDEX TO PRICE LIST

	PAGE		PAGE
Form Truck . . . . .	839	Newspaper Files . . . . .	931
Furniture, Labor-saving . . . . .	797	Newspaper Paster . . . . .	930
Furniture and Reglet . . . . .	796	Numbering Machines . . . . .	900, 901
		Numbering Machine, Wetter . . . . .	849
Galley Cabinets . . . . .	787		
Galley Lock-up . . . . .	784	Overhead Power Fixtures . . . . .	882
Galley Racks . . . . .	786	Overlay Knife . . . . .	833
Galleys . . . . .	782-785		
Gally Universal Cutting and Creas- ing Press . . . . .	860	Padding Glue . . . . .	913
Gally Universal Embossing Press . . . . .	859	Page Cord . . . . .	775
Gas and Gasoline Engine . . . . .	886	Paging Machine, Monitor . . . . .	901
Gauge Pin Drawer . . . . .	835	Pallet, Bookbinders' Lettering . . . . .	914
Gauge Pins and Guides . . . . .	834, 835	Paper Box Cutting and Creasing Press . . . . .	860
Glue Pots . . . . .	913	Paper Counter . . . . .	914
Gold Leaf Stamping Press . . . . .	918	Paper Cutters . . . . .	888-895
Griffin Hack Saws . . . . .	779	—Advance Lever . . . . .	891
Gripper Perforator, Miller's . . . . .	848	—Advance Power . . . . .	892
		—Brown's Latest Improved . . . . .	894
Handy Sort Drawers . . . . .	820	—Challenge . . . . .	893
Hempel Quoins . . . . .	788	—Chandler & Price . . . . .	891
Hercules Gas Engine . . . . .	886	—Clipper . . . . .	890
Hercules Liquid Overlay . . . . .	847	—Peerless . . . . .	893
Hoke Engraving Plates . . . . .	932	—Peerless Gem . . . . .	888, 889
		—Reliance . . . . .	891
Imposing Surfaces, Iron . . . . .	794	—Sheridan Ideal . . . . .	895
Imposing Tables and Stones . . . . .	794, 795	—Sheridan Power . . . . .	895
Ink Knives . . . . .	833	—Utility . . . . .	890
Ink Reducers . . . . .	845, 846	Paper Folders . . . . .	831
Ink Slabs, Marble . . . . .	794	Paper Jogger . . . . .	881
Ink Slice . . . . .	832	Paper Knives . . . . .	833
Inkoleum . . . . .	845	Pasters . . . . .	930
Interlocking Drying Racks, Koer- ner's . . . . .	851	Perforators . . . . .	920-923
		—Franklin Hand . . . . .	920
Kelsey Copy Holder . . . . .	775	—Peerless Rotary . . . . .	923
Knife Grinder . . . . .	896	—Stimpson Lever . . . . .	920
Koerner Drying Racks . . . . .	851	—Stimpson Treadle . . . . .	922
		—Treadle . . . . .	921
Label Holder . . . . .	821	Planers . . . . .	777
Lamp Holder . . . . .	775	Pliers . . . . .	779
Lead and Rule Cutters . . . . .	778, 779	Power Fixtures . . . . .	882
Leader Boxes . . . . .	776	Press Boards, Bookbinders' . . . . .	927
Lead Racks . . . . .	798	Press Points . . . . .	835
Leather Belting . . . . .	831	Press Punch . . . . .	835
Letter Board Cabinets . . . . .	799	Printers' Dividers . . . . .	776
Letter Boards . . . . .	799	Printers' Saw Table . . . . .	824
Linotype Planers . . . . .	777	Printers' Trucks . . . . .	849
Liquid Padding Glue . . . . .	913	Printing Inks . . . . .	843-845
Lock-up Wrenches . . . . .	793	Printing Presses . . . . .	852-881
		—Adams Hand Cylinder . . . . .	863
Mailing Galleys . . . . .	782, 783	—Army . . . . .	865
Mailing Machines . . . . .	928-930	—Campbell Country . . . . .	867
—Acme . . . . .	930	—Challenge Gordon . . . . .	853
—Horton . . . . .	928	—Chandler & Price Old Style Gordon . . . . .	852
—Mustang . . . . .	929	—Cottrell Monarch . . . . .	869
—Rukenbrod . . . . .	929	—Cottrell Paragon . . . . .	870
Make-up Rules . . . . .	774	—Cottrell Triumph . . . . .	868
Make-up Tables . . . . .	793	—Cranston Book and News . . . . .	875
Mallets . . . . .	777	—Cranston Improved Newspaper . . . . .	873
Mitering Machines . . . . .	780	—Cranston Newspaper . . . . .	872
Miter Box . . . . .	776	—Cranston Two-Roller . . . . .	875
		—Cranston-Victor Commercial . . . . .	879

INDEX TO PRICE LIST

	PAGE		PAGE
Printing Presses— <i>Continued.</i>		Side Sticks . . . . .	796
—Cranston-Victor Two-Revolution, Two Rollers . . . . .	877	Stabbing Machine, Hand . . . . .	911
—Cranston-Victor Two-Revolution, Four Rollers . . . . .	881	Stamping Press, Power . . . . .	919
—Gally Universal . . . . .	856-860	Standing Galleys, Wood, etc. . . . .	826, 827
—Golding Jobber . . . . .	861	Standing Galleys, Wrought Iron . . . . .	825, 828
—Harris' Automatic . . . . .	855	Standing Presses, Bookbinders' . . . . .	926
—Ideal Hand Cylinder . . . . .	866	Stamping Press, Hand . . . . .	918
—New Style Franklin Gordon . . . . .	853	Staple Binders . . . . .	902-905
—Official Hand Lever . . . . .	863	—Acme . . . . .	902, 903
—Ostrander-Seymour Pony Web . . . . .	871	—Breech Loader . . . . .	904
—Pearl . . . . .	862	—Hercules . . . . .	905
—Peerless . . . . .	854	—Lightning . . . . .	905
—Pilot Hand Lever . . . . .	863	—No. 8, Saddleback . . . . .	905
—Prouty, Improved Country . . . . .	865	—No. 9 . . . . .	908
—Washington Hand . . . . .	864	—Sure Shot . . . . .	904
Proof Planers . . . . .	777	Stereotype Blocks . . . . .	840-842
Proof Presses . . . . .	822, 823	Stereotyping Apparatus . . . . .	932
Punching Machine . . . . .	915	Stereotype Chases . . . . .	793
Quoin Lock . . . . .	789	Storage Can . . . . .	838
Quoins, Mechanical . . . . .	788, 789	Table Shears . . . . .	898
Quoins, Wooden . . . . .	796	Tablet Knife . . . . .	914
Ratchets for Stereotype Blocks . . . . .	840	Tablet Presses . . . . .	912
Reglet . . . . .	796	Tape . . . . .	830
Reglet Cases, Labor-saving . . . . .	796	Tape Couplers . . . . .	831
Roller Cloth . . . . .	830	Tape Fastener . . . . .	830
Roller Composition . . . . .	839	Tennis Book Sewing Machine . . . . .	911
Roller Composition Kettles . . . . .	839	Thorne Type Setting Machine . . . . .	829
Roller Supporters . . . . .	835	Tint Blocks . . . . .	931
Rollers, Hand . . . . .	839	Tweezers . . . . .	771
Rollers, Prices for Casting . . . . .	839	Tympan Press Boards . . . . .	831
Rule Benders . . . . .	779	Type-high Gauge . . . . .	828
Rule Cases . . . . .	801	Type Measures . . . . .	776
Rule Curving Machine . . . . .	781	Type Wash, Eureka . . . . .	846
Rule Cutters . . . . .	778	Wetter Numbering Machine . . . . .	849
Rule Shapers . . . . .	781	Wire, on Spools . . . . .	909
Ruling Machines . . . . .	924, 925	Wire Staples . . . . .	905
Saws . . . . .	776, 779	Wire Stitchers . . . . .	906-910
Saw Table, Printers' . . . . .	824	—Monitor . . . . .	910
Screw Drivers . . . . .	831	—Perfection . . . . .	906-909
Shears, Bookbinders' . . . . .	898	Wrapper Paster, Economy . . . . .	930
Shooting Sticks . . . . .	777, 831	Wrenches . . . . .	831
		Wooden Galleys . . . . .	784
		Wood Furniture . . . . .	796

DIPLOMA OF AWARD

ONE OF FIVE DIPLOMAS OF AWARD

AWARDED BY THE BOARD OF INTERNATIONAL JUDGES OF THE WORLD'S COLUMBIAN EXPOSITION, CHICAGO, 1893, TO THE AMERICAN TYPE FOUNDERS' COMPANY.

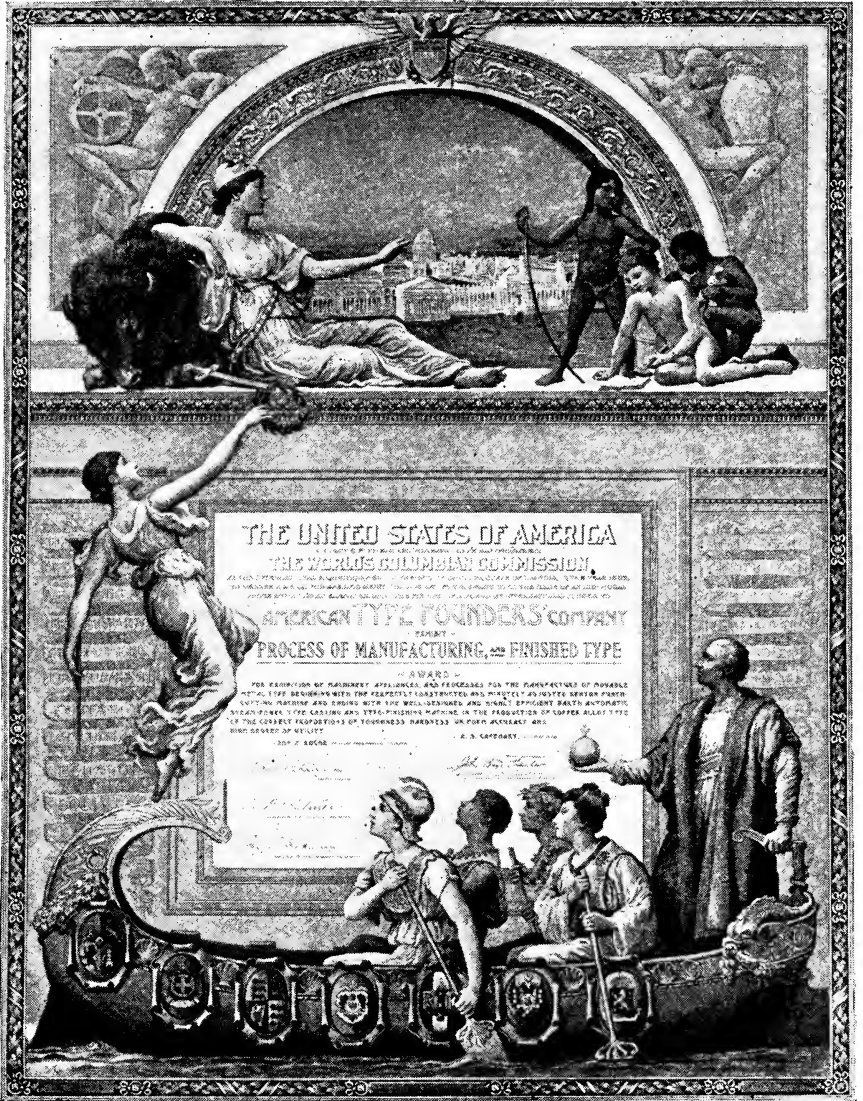

EXHIBIT: PROCESS OF MANUFACTURING, AND FINISHED TYPE AWARD

For Exhibition of Machinery, Appliances and Processes for the Manufacture of Movable Metal Type, beginning with the perfectly constructed and minutely adjusted Benton Punch-Cutting Machine, and ending with the well-designed and highly efficient Barth Automatic Steam-Power Type-Casting and Type-Finishing Machine, in the production of Copper Alloy Type of the correct proportions of Toughness, Hardness, Uniform Accuracy and High Degree of Utility.

**PRICE LIST OF BODY TYPE**

OCTOBER, 1895

POINT BODIES.	25 LBS.	500 LBS.	1000 LBS.
	AND OVER.	AND OVER.	AND OVER.
	Per lb.	Per lb.	Per lb.
3½ Point. . . . .	\$5 00	. . . .	. . . .
3½ " on 4½-Point Body . . . .	3 50	. . . .	. . . .
4½ " . . . . .	1 60	. . . .	. . . .
5 " . . . . .	1 20	. . . .	. . . .
5½ " . . . . .	0 74	\$0 72	\$0 71
6 " . . . . .	0 64	0 62	0 61
7 " . . . . .	0 56	0 54	0 53
8 " . . . . .	0 52	0 50	0 49
9 " . . . . .	0 48	0 46	0 45
10 " . . . . .	0 46	0 44	0 43
11 " . . . . .	0 44	0 42	0 41
12 " . . . . .	0 42	0 40	0 40
14 " . . . . .	0 40	. . . .	. . . .
15 " . . . . .	0 40	. . . .	. . . .
16 " . . . . .	0 40	. . . .	. . . .
18 " . . . . .	0 40	. . . .	. . . .

Roman and German Body Type is put up in fonts of 25, 50 and 100 pounds, or some multiple of these weights. Included in each 25 pounds are 5 pounds of Spaces and Quads, and same proportions in larger fonts.

Italic and Accents will not be sent with Roman fonts unless specially ordered. Smallest font of Italic furnished weighs 5 pounds. A pair of full-size cases holds 50 pounds of body type.

**Spaces and Quads in Job Fonts**

5 Point . . . . . \$1 40	15 Point . . . . . \$0 60	40 Point . . . . . \$0 60
5½ " . . . . . 1 00	16 " . . . . . 0 55	42 " . . . . . 0 60
6 " . . . . . 0 65	18 " . . . . . 0 55	44 " . . . . . 0 60
7 " . . . . . 0 65	20 " . . . . . 0 60	48 " . . . . . 0 80
8 " . . . . . 0 65	22 " . . . . . 0 50	54 " . . . . . 1 10
9 " . . . . . 0 60	24 " . . . . . 0 60	60 " . . . . . 1 15
10 " . . . . . 0 55	28 " . . . . . 0 55	72 " . . . . . 1 25
11 " . . . . . 0 60	30 " . . . . . 0 50	84 " . . . . . 0 90
12 " . . . . . 0 60	32 " . . . . . 0 50	96 " . . . . . 1 70
14 " . . . . . 0 60	36 " . . . . . 0 55	120 " . . . . . 1 40

**Allowance for Old Type and other Metals**

Old type (clean and unmixed with other metals), electrotypes, leads and brass, delivered at foundry free, will be taken at current prices in even exchange for new type or printing material.

Customers sending in old metal are requested to mark their names on all packages, and to forward by mail a shipping receipt or bill of lading, with the net weight of each kind of material, as soon as shipment is made. Compliance with this request will aid in identifying shipments, and prevent errors. Ship as "old metal" to secure low freight rate.

SPECIAL NOTICE.—Zinc plates, metal containing zinc, or type and other plates mixed with zinc plates, and stereotype plates, will not be received at any price. Type, electrotype plates, leads and brass, must be packed separately, as the value of each differs.

**Type Standards**

The following is the standard adopted by the International Typographical Union. The basis of measurement is the lower-case alphabet, from a to z inclusive, and the ems used are the same body as the type measured:

	EMS		EMS
4½ Point . . .	18	8 Point . . .	14
5 " " . . .	17	9 " " . . .	13
5½ " " . . .	16	10 " " . . .	13
6 " " . . .	15	11 " " . . .	13
7 " " . . .	14	12 " " . . .	13

**How to Estimate**

To ascertain the quantity of body type required for a publication, find the number of square inches and divide the same by four, and the quotient will be the approximate weight of type required; but, as it is impossible to set the cases entirely clear, it is necessary to add 25 per cent. to the weight of large fonts, and 33½ per cent. to small fonts, to allow for dead letter.

**Number of Ems in One Pound of Type**

Two by two inches (four square inches) solid type weighs approximately one pound.

	EMS		EMS
5 Point . . .	829	9 Point . . .	256
5½ " " . . .	685	10 " " . . .	207
6 " " . . .	576	11 " " . . .	171
7 " " . . .	423	12 " " . . .	144
8 " " . . .	324		

**Useful in Ordering Sorts**

The following table shows what each box in the type case will hold:

LETTERS.	WEIGHT IN FULL BOX.
a c d i s m n h o u t r .	2 pounds.
f b l v g y p w . . . . .	15 ounces.
k j z x q and all figs. .	6 " "
e . . . . .	3 pounds.
Caps and Small Caps	5 ounces.

**American Point System**

The following table gives the names of the old bodies and their new designation by points:

3½ Point . . .	Brilliant.
4½ " " . . .	Diamond.
5 " " . . .	Pearl.
5½ " " . . .	Agate.
6 " " . . .	Nonpareil.
7 " " . . .	Minion.
8 " " . . .	Brevier.
9 " " . . .	Bourgeois.
10 " " . . .	Long Primer.
11 " " . . .	Small Pica.
12 " " . . .	Pica.
14 " " . . .	2-line Minion or English.
16 " " . . .	2-line Brevier.
18 " " . . .	Great Primer.
20 " " . . .	2-line Long Prim. or Paragon
22 " " . . .	2-line Small Pica.
24 " " . . .	2-line Pica.
28 " " . . .	2-line English.
30 " " . . .	5-line Nonpareil.
32 " " . . .	4-line Brevier.
36 " " . . .	2-line Great Primer.
40 " " . . .	Double Paragon.
42 " " . . .	7-line Nonpareil.
44 " " . . .	4-line Small Pica or Canon.
48 " " . . .	4-line Pica.
54 " " . . .	9-line Nonpareil.
60 " " . . .	5-line Pica.
72 " " . . .	6-line Pica.

**Standard Sizes of Newspapers**

This table of sizes is based upon the standard sizes of newspapers, with columns 13 twelve-point ems wide and six-point column rules. The adoption of these sizes is advisable especially in starting newspapers or putting in new outfits, thereby gaining desirable uniformity:

	Standard Size of Paper. INCHES.	Size of Each Page. INCHES.	* Face Length of 6 Pt. Col. Rules. INCHES.	Length of Head Rules required.
4-Column Quarto . . .	22 × 30 . . .	8½ × 14 . . .	13¾ . . .	53½ Pica ems.
5 " " " . . .	26 × 40 . . .	11½ × 18 . . .	17¾ . . .	67 " "
6 " " " . . .	30 × 44 . . .	13¾ × 20 . . .	19¾ . . .	80½ " "
7 " " " . . .	35 × 48 . . .	15¾ × 22 . . .	21¾ . . .	94 " "
8 " " " . . .	40 × 52 . . .	17½ × 24 . . .	23¾ . . .	107½ " "
5 " " Folio . . .	20 × 26 . . .	11½ × 18 . . .	17¾ . . .	67 " "
6 " " " . . .	22 × 30 . . .	13¾ × 20 . . .	19¾ . . .	80½ " "
7 " " " . . .	24 × 35 . . .	15¾ × 22 . . .	21¾ . . .	94 " "
8 " " " . . .	26 × 40 . . .	17½ × 24 . . .	23¾ . . .	107½ " "
9 " " " . . .	28 × 44 . . .	20½ × 26 . . .	25¾ . . .	121 " "

\* Length of column rules for first page determined by size of headings, or say about two inches shorter than full length.



## COPPER ALLOY TYPE

### NEWSPAPER MEASUREMENTS

Table showing the number of ems of the different sizes of Newspaper Type in a line, the number of lines necessary to make 1000 ems, and the length in inches. Also the number of ems in the regular lengths of column.

13 EMS PICA, WIDTH OF STANDARD COLUMN.	5½ POINT.	6 POINT.	7 POINT.	8 POINT.	9 POINT.	10 POINT.
Number ems in line . . . . .	28 $\frac{2}{3}$	26	22 $\frac{1}{4}$	19 $\frac{1}{2}$	17 $\frac{1}{3}$	15 $\frac{1}{2}$
Number lines in 1000 ems . . . . .	35 $\frac{1}{3}$	38 $\frac{1}{2}$	45	51 $\frac{1}{3}$	57 $\frac{2}{3}$	64 $\frac{1}{2}$
Number inches in 1000 ems . . . . .	2 $\frac{2}{3}$	3 $\frac{1}{4}$	4 $\frac{3}{8}$	5 $\frac{2}{3}$	7 $\frac{1}{4}$	9
4-Col. Folio or Quarto } 5-Col. Folio or Quarto } 6-Col. Folio or Quarto } 7-Col. Folio or Quarto } 8-Col. Folio, No. ems in column . 9-Col. Folio, No. ems in column .	5040 6505 7180 7900 8630 9310	4325 5615 6160 6785 7410 8030	3175 4115 4515 4970 5440 5885	2465 3200 3510 3865 4220 4575	1950 2525 2770 3050 3330 3615	1610 2085 2290 2520 2755 2970
	No. ems in col.					

### LEADS FOR NEWSPAPERS

Table showing the number of leads, 13 ems long, contained in one pound, and the number required to lead 1000 ems of matter. Also the number of leads in a single column of matter, regular newspaper size.

SIZES OF BODY TYPE. LEADS USED ARE SIX-TO-PICA.	5½ POINT.	6 POINT.	7 POINT.	8 POINT.	9 POINT.	10 POINT.
Number leads to the pound . . . . .	60	60	60	60	60	60
Number leads to 1000 ems . . . . .	26	29	34	40	45	52
4-Col. Folio or Quarto, No. leads in column . . . . .	132	125	108	99	88	84
5-Col. Folio or Quarto, No. leads in column . . . . .	170	162	140	128	114	108
6-Col. Folio or Quarto, No. leads in column . . . . .	185	179	154	141	125	119
7-Col. Folio or Quarto, No. leads in column . . . . .	206	197	169	155	138	131
8-Col. Folio, No. leads in column . . . . .	224	215	185	169	150	143
9-Col. Folio, No. leads in column . . . . .	241	233	201	183	163	154

### A VALUABLE TABLE

The following table, invaluable for reference, shows the number of leads to the pound in the several lengths and thicknesses Pica given:

LENGTHS.	FOUR- TO-PICA.	SIX- TO-PICA.	EIGHT- TO-PICA.	LENGTHS.	FOUR- TO-PICA.	SIX- TO-PICA.	EIGHT- TO-PICA.
4 ems . . . . .	114	216	288	16 ems . . . . .	36	54	72
5 ems . . . . .	112	168	224	17 ems . . . . .	34	51	68
6 ems . . . . .	96	144	192	18 ems . . . . .	32	48	64
7 ems . . . . .	82	123	164	19 ems . . . . .	30	45	60
8 ems . . . . .	72	108	144	20 ems . . . . .	28	42	56
9 ems . . . . .	64	96	128	21 ems . . . . .	27	40	54
10 ems . . . . .	56	84	112	22 ems . . . . .	26	39	52
11 ems . . . . .	52	78	104	23 ems . . . . .	25	37	50
12 ems . . . . .	48	72	96	24 ems . . . . .	24	36	48
13 ems . . . . .	44	66	88	25 ems . . . . .	23	34	46
14 ems . . . . .	41	61	82	26 ems . . . . .	22	33	44
15 ems . . . . .	38	57	76	27 ems . . . . .	21	31	42

# Brass Type for Bookbinders

## BRASS TYPE, BORDERS AND ORNAMENTS

A special Specimen Book of Brass Type will be sent on application. The following series, or parts of them, shown in this Specimen Book, are made in Solid Brass :

	PAGE
Anglo-Saxon . . . . .	589
Antique Condensed Nos. 122 and 116 (Caps) . . . . .	218, 219
Antique Extra Condensed No. 150 (Caps) . . . . .	220, 221
Antique No. 125 (Caps) . . . . .	212, 213
Art Gothic . . . . .	442
Atlanta . . . . .	420, 421
Condensed Aldine No. 150 (Caps) . . . . .	190, 191
Condensed No. 124 . . . . .	170, 171
Edinburgh Title . . . . .	146
Facade . . . . .	476, 477
French Old Style No. 1 . . . . .	142, 143
Gothic Condensed No. 124 (Caps) . . . . .	294, 295
Gothic Extra Condensed No. 150 (Caps) . . . . .	298
Gothic No. 127 . . . . .	276, 277
Gothic No. 1510 . . . . .	281
Lafayette (Caps) . . . . .	414, 415
Latin No. 20 (Caps) . . . . .	267
Latin Antique No. 120 (Caps) . . . . .	162, 163
Latin Condensed No. 150 (Caps) . . . . .	248, 249
Modern Antique (Caps) . . . . .	250-252
Mural . . . . .	474, 475
Norman Condensed . . . . .	487
Novelty Script . . . . .	577
Old Style Bold (Caps) . . . . .	167
Old Style Extended (Caps) . . . . .	154, 155
Old Style No. 43 . . . . .	144
Two-Line No. 124 . . . . .	172
Two-Line No. 151 . . . . .	175
Victoria . . . . .	422, 423
Yonkers . . . . .	593

Also a Collection of Forty-five Beautiful Borders and  
Thirty-nine Word Ornaments

COPPER ALLOY TYPE

**BRASS RULES**

—12—

*All our Brass Rule sold in strips of two feet each. For Labor-Saving Brass Rules, see pages 32-35.*

NO.	BODY	PER FOOT
198E	1 Point	\$0 05
201E	1½ Point	6
203E	2 Point	8
206E	3 Point	12
207E	4 Point	16
500E	5 Point	20
208E	5½ Point	22
209E	6 Point	28
210E	7 Point	32
211E	8 Point	34
212E	9 Point	38
213E	10 Point	40
214E	11 Point	45
215E	12 Point	50
216E	1½ Point	6
220E	2 Point	8
501E	1½ Point	6
502E	2 Point	8
503E	3 Point	12

NO	BODY	PER FOOT
504E	4 Point	\$0 16
505E	5 Point	20
506E	6 Point	28
507E	7 Point	32
508E	8 Point	34
509E	9 Point	38
510E	10 Point	40
511E	11 Point	45
512E	12 Point	50
513E	1 Point	5
514E	1½ Point	6
515E	2 Point	8
516E	3 Point	12
517E	4 Point	16
518E	5 Point	20
519E	6 Point	28

*All Brass Rules on this page cut labor-saving. See prices on pages 32, 34.*

AMERICAN TYPE FOUNDERS CO.

NO.	BODY	PER FOOT	NO	BODY	PER FOOT
520E	1½ Point	\$0 06	339E	2 Point	\$0 08
521E	2 Point	8	339½E	1½ Point	6
522E	3 Point	12	340E	2 Point	8
523E	4 Point	16	340¼E	1½ Point	6
524E	5 Point	20	341E	2 Point	8
525E	6 Point	28	341½E	1½ Point	6
177E	1 Point	5	342E	2 Point	8
180E	1½ Point	6	343E	2 Point	8
182E	2 Point	8	234E	2 Point	8
185E	3 Point	12	235E	3 Point	12
187E	4 Point	16	236E	3 Point	12
189E	5 Point	20	237E	4 Point	16
191E	6 Point	28	238E	5 Point	20
192E	7 Point	32	239E	5½ Point	22
193E	8 Point	34	241E	6 Point	28
194E	9 Point	38	245E	3 Point	12
195E	10 Point	40	246E	5 Point	20
196E	11 Point	45	247E	5½ Point	22
197E	12 Point	50	252E	4 Point	16
197½E	18 Point	60	253E	5 Point	20
			254E	5½ Point	22
			255E	6 Point	28

All Brass Rules on this page cut labor-saving. See prices on pages 32, 34.

*COPPER ALLOY TYPE*

NO.	BODY	PER FOOT
262E	3 Point	\$0 12
263E	4 Point	16
264E	5 Point	20
265E	5½ Point	22
266E	6 Point	28
267E	7 Point	32
268E	8 Point	34
269E	9 Point	38
271E	4 Point	16
272E	4 Point	16
273E	5 Point	20
274E	5½ Point	22
275E	6 Point	28
276E	7 Point	32
281E	3 Point	12
282E	4 Point	16
283E	5 Point	20
284E	6 Point	28
285E	6 Point	28
286E	7 Point	32

NO.	BODY	PER FOOT
287E	8 Point	\$0 34
288E	10 Point	40
289E	11 Point	45
290E	12 Point	50
290½E	2 Point	8
291E	3 Point	12
292E	4 Point	16
293E	5 Point	20
294E	5½ Point	22
295½E	5½ Point	22
296E	6 Point	28
297E	6 Point	28
298E	8 Point	34
299E	9 Point	38
301E	10 Point	40
302E	11 Point	45
304E	12 Point	50
305E	18 Point	60

*All Brass Rules on this page cut labor-saving See prices on pages 32, 34.*

AMERICAN TYPE FOUNDERS CO.

NO.	BODY	PER FOOT
312E	5½ Point	\$0 22
313E	5 Point	20
314E	7 Point	32
316E	8 Point	34
317E	9 Point	38
318E	11 Point	45
319E	5 Point	20
321E	5½ Point	22
322E	7 Point	32
323E	8 Point	34
324E	10 Point	40
325E	12 Point	50
326E	5 Point	20
327E	5½ Point	22
328E	7 Point	32
329E	8 Point	34
330E	9 Point	38
331E	10 Point	40

NO.	BODY	PER FOOT
332E	7 Point	\$0 32
333E	9 Point	38
334E	11 Point	45
338E	9 Point	38
344E	2 Point	8
345E	2 Point	8
346E	2 Point	14
347E	3 Point	16
348E	4 Point	20
349E	5½ Point	26
350E	2 Point	14
351E	3 Point	16
352E	4 Point	20
353E	5½ Point	26
354E	1½ Point	10
355E	2 Point	14
356E	2 Point	14
357E	3 Point	16
358E	3 Point	16
359E	4 Point	20
360E	4 Point	20
361E	5½ Point	26
362E	5½ Point	26

The Brass Rules on this page cut labor-saving except Nos. 344E to 362E inclusive. See prices on pages 32, 34.

COPPER ALLOY TYPE

NO.	BODY	PER FOOT
363E	2 Point	\$0 14
364E	2 Point	14
365E	2 Point	14
366E	2 Point	14
367E	2 Point	14
368E	2 Point	14
371E	2 Point	16
372E	2 Point	16
373E	2 Point	16
374E	2 Point	16
375E	2 Point	16
376E	4 Point	22
377E	4 Point	20
378E	5½ Point	28
380E	3 Point	18
382E	4 Point	22
383E	4 Point	20
385E	4 Point	22
386E	4 Point	20
387E	5½ Point	26
388E	5½ Point	28
389E	5½ Point	28

NO.	BODY	PER FOOT
390E	5½ Point	\$0 28
391E	5½ Point	26
392E	5½ Point	26
395E	6 Point	32
396E	5½ Point	30
399E	5½ Point	34
400E	5½ Point	32
401E	3 Point	16
402E	4 Point	20
404E	4 Point	20
406E	5½ Point	26
408E	7 Point	36
409E	5½ Point	28
410E	7 Point	36
411E	7 Point	36
412E	8 Point	40
424E	7 Point	44
425E	9 Point	46
426E	11 Point	56

The Brass Rules on this page cannot be cut labor-saving.

AMERICAN TYPE FOUNDERS CO.

NO.	BODY	PER FOOT
432E	5½ Point	\$0 30
433E	8 Point	42
434E	6 Point	36
435E	8 Point	42
436E	5 Point	22
437E	5 Point	22
438½E	6 Point	36
439½E	6 Point	36
440½E	6 Point	36
441E	8 Point	42
442E	8 Point	42
443E	10 Point	48
619B	6 Point	40
308B	2 Point	12
309B	3 Point	18
310B	4 Point	22
311B	5 Point	27
312B	6 Point	32
313B	8 Point	42
314B	12 Point	65

NO.	BODY	PER FOOT
444E	4 Point	\$0 22
447E	4 Point	22
448E	6 Point	36
449E	10 Point	48
450E	4 Point	22
452E	10 Point	48
454E	9 Point	48
455E	5½ Point	32
456E	4 Point	24
457E	5½ Point	32
469E	5 Point	32
470E	6 Point	36
620B	6 Point	40
362B	2 Point	12
363B	3 Point	18
364B	4 Point	22
365B	5 Point	27
366B	6 Point	32
367B	8 Point	42
368B	12 Point	65

The Brass Rules on this page cannot be cut labor-saving.



COPPER ALLOY TYPE

NO.	BODY	PER FOOT	NO.	BODY	PER FOOT
533B	2 Point	\$0 12	510B	2 Point	\$0 12
534B	3 Point	18	511B	3 Point	18
535B	4 Point	22	512B	4 Point	22
536B	5 Point	27	513B	5 Point	27
537B	6 Point	32	514B	6 Point	32
538B	8 Point	42	515B	8 Point	42
539B	12 Point	65	516B	12 Point	65
980F	6 Point	40	980½F	6 Point	40
981F	8 Point	50	981½F	8 Point	50
982F	9 Point	60	982½F	9 Point	60
983F	10 Point	65	983½F	10 Point	65
984F	12 Point	70	984½F	12 Point	70
324B	2 Point	12	1036F	6 Point	40
325B	3 Point	18	1037F	12 Point	70
326B	4 Point	22	1038F	18 Point	1 10
327B	5 Point	27	1044F	9 Point	60
328B	6 Point	32	1041F	12 Point	70
329B	8 Point	42			
330B	12 Point	65			

Brass Rules with initial B are 24 inches long; with initial F, 12 inches.

**Labor-Saving Brass Rule**

-12-

*Labor-Saving Brass Rules are cut in length to Twelve Point body, unless otherwise ordered, and are graduated by ens and ems. All fonts have mitred corner pieces. Special prices on application for Labor-Saving Ornamental Brass Rules.*

NO. 219E					
2 POINT BODY					
<b>Price per Font</b>					
PT.	NO.	2-LB.	3-LB.	5-LB.	10-LB.
2	203E	\$3 50	\$5 25	\$8 25	\$16 50
2	219E	3 50	5 25	8 25	16 50
2	340E	3 50	5 25	8 25	16 50
2	341E	3 50	5 25	8 25	16 50
3	236E	3 20	4 80	7 50	15 00
3	281E	3 20	4 80	7 50	15 00
4	237E	3 00	4 50	7 00	14 00

NO. 281E			
3 POINT BODY			
<b>Price for Fonts</b>			
	PER LB.		PER LB.
2 POINT.	...\$1 75	6 POINT....	\$1 50
3 "	.... 1 60	7 "	.... 1 50
4 "	.... 1 50	8 "	.... 1 50
		10 POINT....	\$1 40

COPPER ALLOY TYPE

NO. 340E 2 POINT BODY

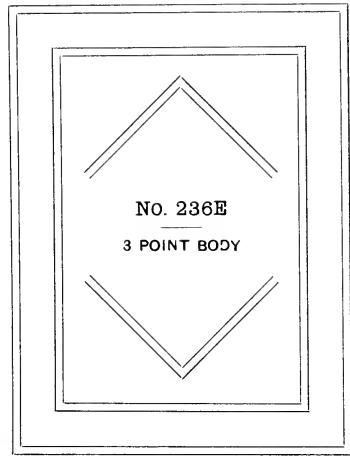
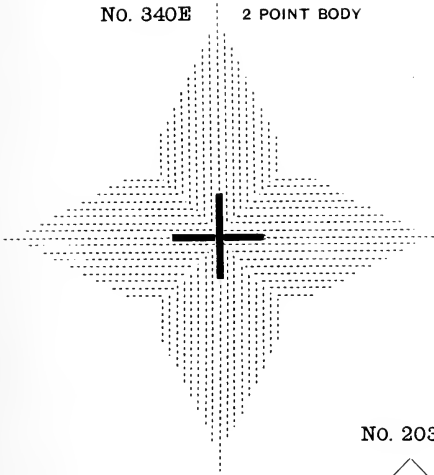

NO. 203E

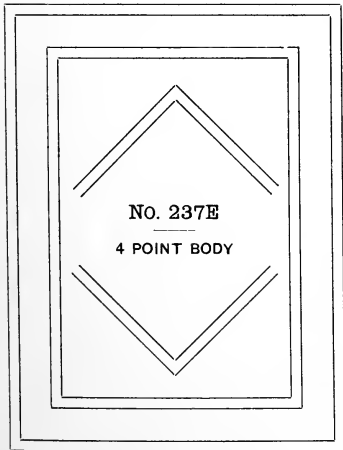
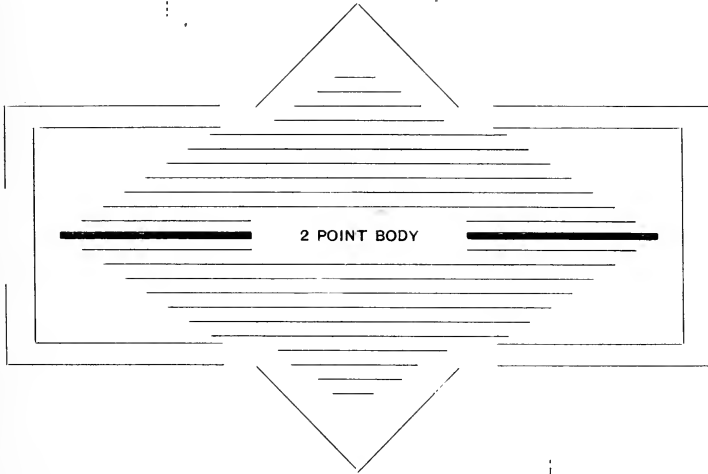

NO. 341E 2 POINT BODY

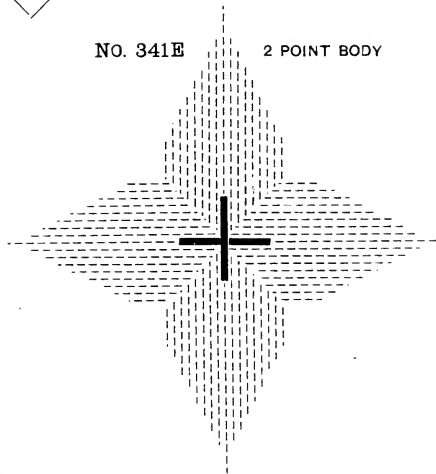

AMERICAN TYPE FOUNDERS CO.

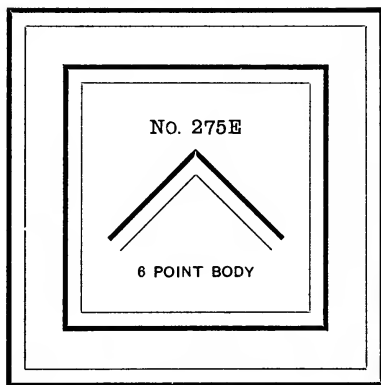
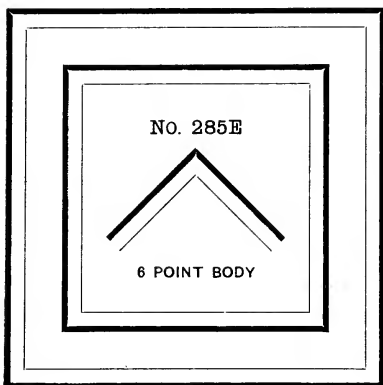

NO. 288E 10 POINT BODY

*Price per Font*

PT.	NO.	2-LB.	3-LB.	5-LB.	10-LB.
4	282E	\$3 00	\$4 50	\$7 00	\$14 00
4	292E	3 00	4 50	7 00	14 00
6	266E	3 00	4 50	7 00	14 00
6	275E	3 00	4 50	7 00	14 00
6	284E	3 00	4 50	7 00	14 00
6	285E	3 00	4 50	7 00	14 00
6	296E	3 00	4 50	7 00	14 00
6	297E	3 00	4 50	7 00	14 00
8	287E	.....	4 50	7 00	14 00
10	288E	.....	.....	7 00	13 50
10	301E	.....	.....	7 00	13 50

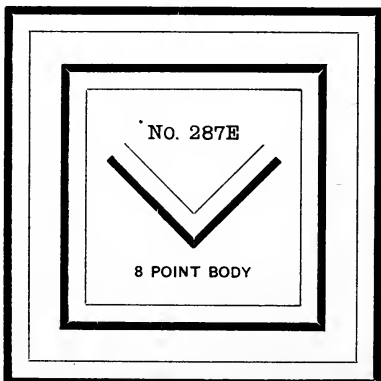
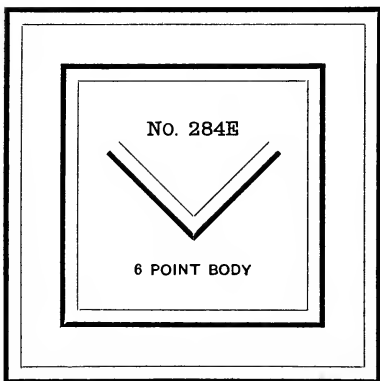

COPPER ALLOY TYPE

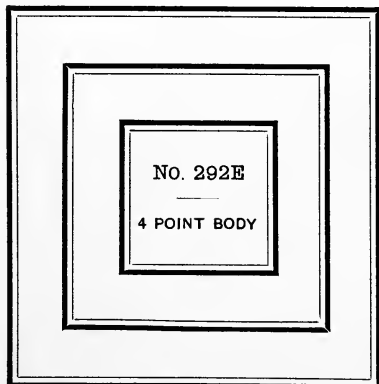
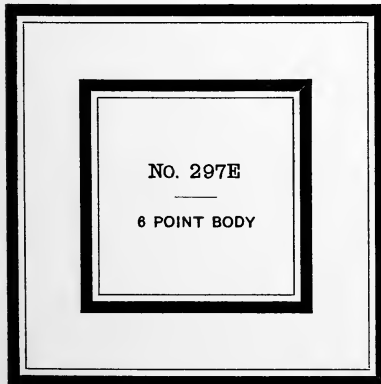
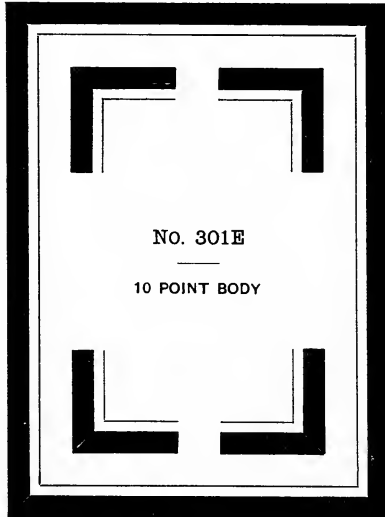
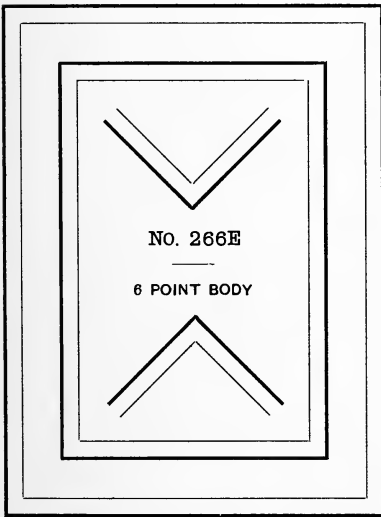
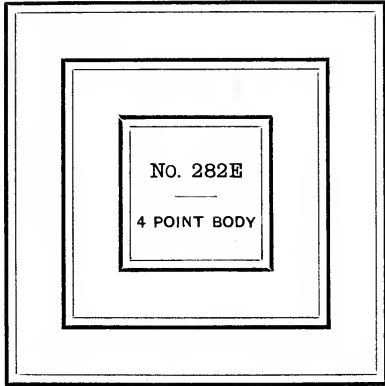
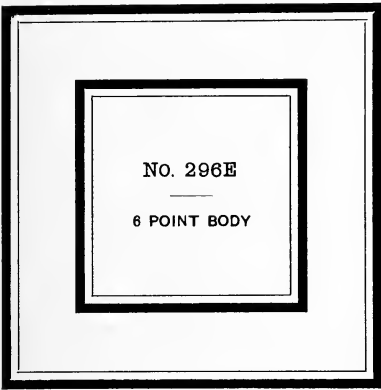

**BRASS CIRCLES AND OVALS**

12

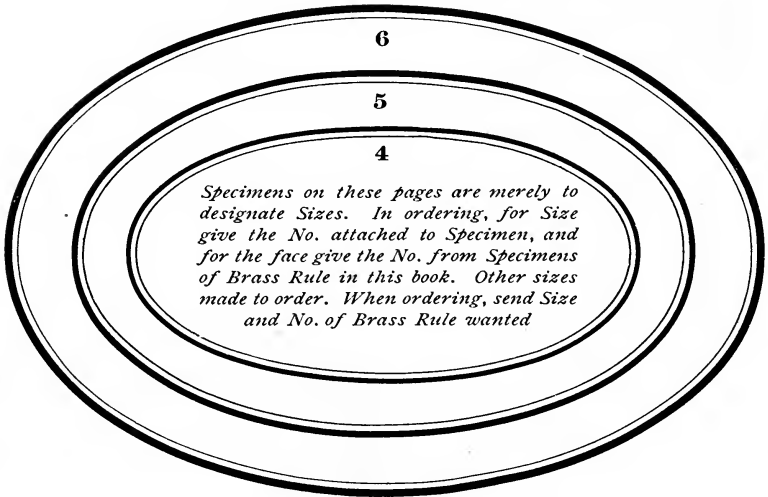

OVALS—NOS. 4, 5 AND SMALLER, 90 CENTS. NO. 6, \$1 25  
CIRCLES—NOS. 1, 3 AND 5, 60 CENTS. NOS. 7 AND 9, 75 CENTS NO. 11, \$1 00

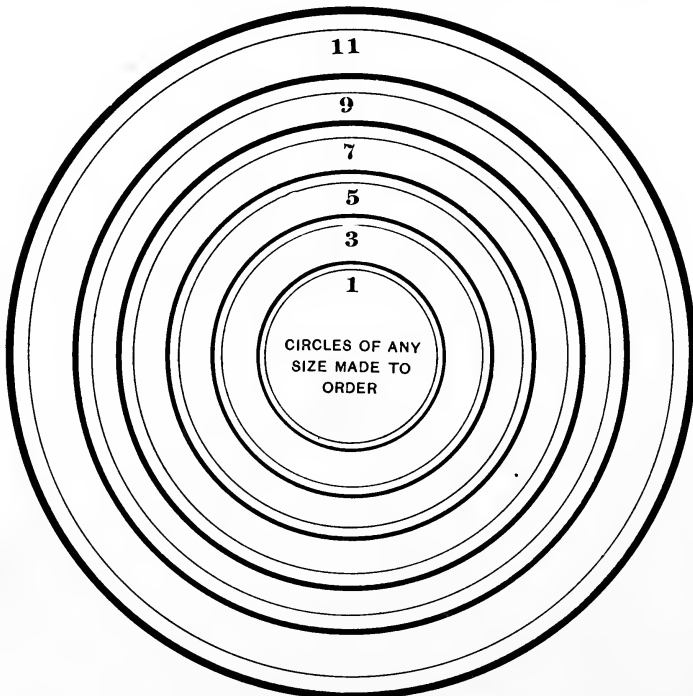

*These Circles and Ovals are made from Seamless Brass Tubing*

**BRASS CIRCLES**

12

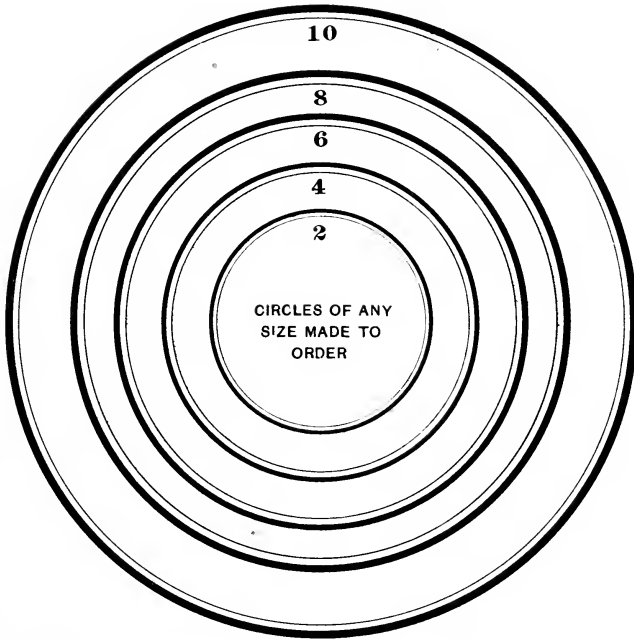

CIRCLES—NOS. 2, 4, 6, 15, 16 AND 17, 60 CENTS. NOS. 8 AND 18, 75 CENTS  
NOS. 10 AND 19, \$1 00

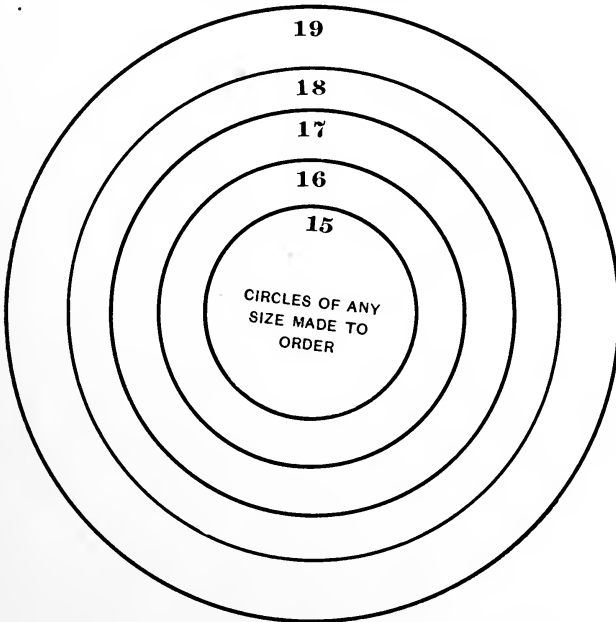

**BRASS DASHES**

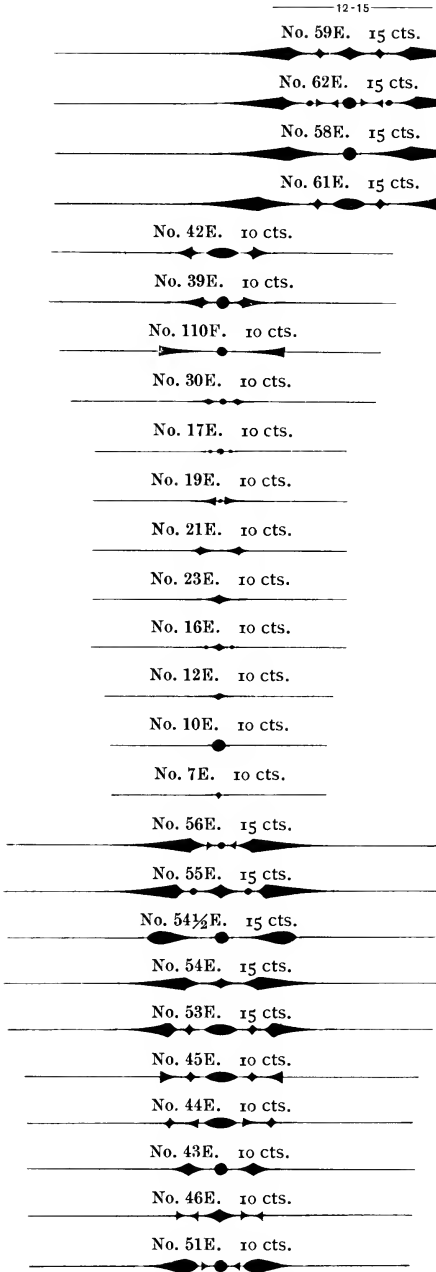

**BRASS JOB DASHES**

*2 Point body, 5c. each.  
Length of face and body  
is here shown. Can be  
cut shorter, if so ordered*

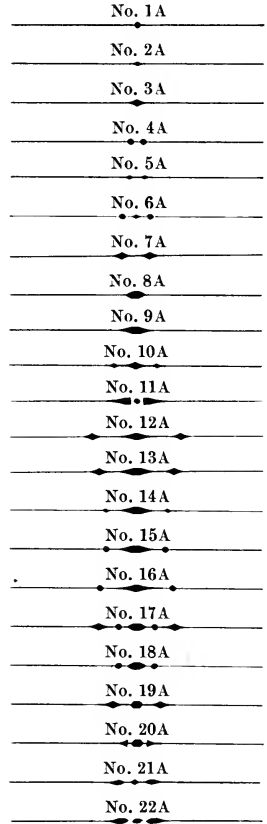

*All Brass Dashes that are sold for 10 cents each, supplied any length for News Columns not exceeding 15 ems Pica*



COPPER ALLOY TYPE

**BRASS DASHES**

No. 36E. 10 cts.	12-15	No. 14E. 10 cts.
No. 41E. 10 cts.		No. 15E. 10 cts.
No. 101F. 10 cts.		No. 24E. 10 cts.
No. 33E. 10 cts.		No. 22E. 10 cts.
No. 29E. 10 cts.		No. 31E. 10 cts.
No. 27E. 10 cts.		No. 32E. 10 cts.
No. 24½E. 10 cts.		No. 28E. 10 cts.
No. 18E. 10 cts.		No. 172F. 10 cts.
No. 11E. 10 cts.		No. 38E. 10 cts.
No. 9E. 10 cts.		No. 34E. 10 cts.
No. 60E. 15 cts.		No. 2E. 10 cts.
No. 63E. 15 cts.		No. 3E. 10 cts.
No. 52E. 15 cts.		No. 1E. 10 cts.
No. 57E. 15 cts.		No. 5E. 10 cts.
No. 47E. 10 cts.		No. 6E. 10 cts.
No. 48E. 10 cts.		No. 13E. 10 cts.

*All Brass Dashes that are sold for 10 cents each, supplied any length for News Columns not exceeding 15 ems Pica*

**BRASS BRACES**







No. 12. 15 cts.	4	No. 11. 15 cts.
No. 13. 15 cts.		No. 10. 12 cts.
No. 14. 15 cts.		No. 9. 12 cts.
No. 15. 15 cts.		No. 8. 12 cts.
No. 16. 15 cts.		No. 7. 12 cts.
No. 17. 15 cts.		No. 6. 12 cts.
No. 18. 18 cts.		No. 5. 12 cts.
No. 19. 18 cts.		No. 4. 12 cts.
No. 20. 18 cts.		No. 3. 12 cts.
No. 21. 18 cts.		No. 2. 12 cts.
No. 22. 18 cts.		No. 1. 12 cts.
No. 23. 25 cts.		

**BRASS HEAD RULES**

The following prices are for any Single, Double, Parallel or Triple Rule shown in this book:

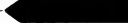
BODY.	4-COL.	5-COL.	6-COL.	7-COL.	8-COL.	9-COL.
3 Point	\$.15	\$.15	\$.20	\$.23	\$.25	\$.30
4 "	.15	.15	.20	.23	.25	.30
5 "	.15	.20	.23	.25	.30	.35
5½ "	.20	.22	.25	.30	.33	.40
6 "	.25	.30	.35	.40	.45	.50
7 "	.25	.30	.35	.40	.48	.55
8 "	.30	.35	.40	.45	.50	.60
No. 236E						3 Point
No. 237E						4 Point
No. 239E						5½ Point
No. 241E						6 Point
No. 273E						5 Point
No. 274E						5½ Point
No. 275E						6 Point
No. 285E						6 Point
No. 293E						5 Point
No. 295½E						5½ Point
No. 296E						6 Point
No. 297E						6 Point

**BRASS COLUMN RULES**

SIZE	FACE LENGTH	6 PT.	7 PT.	8 PT.	9 PT.	10 FT.
4 Column	13¾ inches	\$.35	\$.40	\$.40	\$.45	\$.50
5 "	17¾ "	.40	.50	.50	.55	.60
6 "	19¾ "	.47	.55	.60	.65	.70
7 "	21¾ "	.50	.60	.65	.70	.75
8 "	23¾ "	.50	.65	.70	.75	.80
9 "	25¾ "	.54	.70	.75	.80	.90
6 Point		9 Point				
7 Point		10 Point				
8 Point						

Column Rules nicked under for the use of Brass Reglet, 10 cents extra; nicked under and over for Perfecting Presses, 25 cents each extra.

COPPER ALLOY TYPE

**ADVERTISING RULES**

Prices quoted are for columns 15 Pica ems wide and under

	SINGLE COL.	DOUBLE COL.
No. 203E	4 cts.	6 cts.
No. 219E	4 cts.	6 cts.
No. 237E	6 cts.	10 cts.
No. 239E	6 cts.	10 cts.
No. 273E	6 cts.	10 cts.
No. 274E	6 cts.	10 cts.
No. 275E	6 cts.	10 cts.
No. 291E	6 cts.	10 cts.
No. 293E	6 cts.	10 cts.
No. 295½E	6 cts.	10 cts.
No. 365E	5 cts.	8 cts.
No. 367E	5 cts.	8 cts.

**Brass Dash Rules**

Cut to single columns not exceeding 15 Pica ems in width. The specimens show length of face furnished unless otherwise ordered

	EACH
No. 203A	6 cts.
No. 203B	6 cts.
No. 203C	6 cts.
No. 203D	6 cts.
No. 219E	6 cts.
No. 237E	8 cts.
No. 273E	8 cts.
No. 291E	8 cts.
No. 293E	8 cts.
No. 294E	8 cts.
No. 364F	7 cts.
No. 365E	7 cts.
No. 368E	8 cts.
No. 375E	8 cts.

**IMPROVED PATENT**  
**BRASS**  
**CURVES & CLAMPS,**  
**FORMING**  
**EVERY VARIETY OF CURVED LINES.**

Patented Sept. 2, 1873.  
 Fonts of 170 pieces. Price, \$8.00.









CLAMPS.  
 From Nonpareil to Four-line Pica.

Fonts, containing 170 pieces, ranging from 6 Point to 48 Point bodywise, and from 5 ems Pica to 36 ems Pica lengthwise, designed to form a great variety of curved lines, and also for setting straight lines, \$8.00.

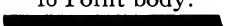
**LABOR-SAVING BRASS LEADERS**

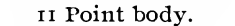
(Hyphen or Dotted) from 12 Points to 216 Points in length

	PER LB.		PER LB.		PER LB.
5 Point . . . . .	\$1 60	7 Point . . . . .	\$1 60	10 Point . . . . .	\$1 50
5½ " . . . . .	1 60	8 " . . . . .	1 60	11 " . . . . .	1 40
6 " . . . . .	1 60	9 " . . . . .	1 50	12 " . . . . .	1 40

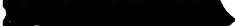
5 Point body.	Faces.	9 Point body.	Faces.
	-----		-----
5½ Point body.	-----	10 Point body.	-----
	-----		-----
6 Point body.	-----	11 Point body.	-----
	-----		-----
7 Point body.	-----	12 Point body.	-----
	-----		-----
8 Point body.	-----		-----
	-----		

When ordering, be particular to state the style of Leader (whether Dotted or Hyphen) as well as the face of the type with which the Leaders are to be used, and send a cap H and lower case m, so that exact line may be assured.

**BRASS LEADS AND SLUGS**

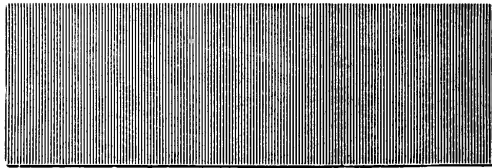

	CUT TO COLUMN MEASURE	CUT LABOR- SAVING
1 Point, per lb.,	\$1.00	\$1.50
1½ " " "	0.80	1.25
2 " " "	0.75	1.25
6 Pt. and thicker "	0.75	1.00

**Perforating Rules**

BRASS	PER FOOT
700E . . . . . 2 Point . . . . .	15 Cts.
701E . . . . . 3 Point . . . . .	18 cts.
710E . . . . . 17 teeth to 1 in. . . . .	50 cts.
711E . . . . . 12 teeth to 1 in. . . . .	50 cts.
712E . . . . . 8¼ teeth to 1 in. . . . .	50 cts.

**Brass Scoring Rules**

2 Point, per foot . . . . .	.08
3 " " " " . . . . .	.12
4 " " " " . . . . .	.16
6 " " " " . . . . .	.28

**Steel Cutting Rules**

2 Point, regular . . . . . per foot	.20
2 " bright and hard " . . . . .	.30
3 " regular . . . . . " . . . . .	.30
6 " " " " . . . . . " . . . . .	.50

**Brass Space Rules**

1 Point . . . . . per pound,	\$3.50
1½ " . . . . . " . . . . .	2.75
2 " . . . . . " . . . . .	2.00

COPPER ALLOY TYPE

SHAVED LEADS AND SLUGS

12

	UNCUT	CUT TO MEASURE
1 Point (12-to-Pica), per pound . . . . .	\$0 50	\$0 65
1½ " (10-to-Pica) " " . . . . .	40	50
1½ " (8-to-Pica) " " . . . . .	32	40
2 " (6-to-Pica) " " . . . . .	} 16	18
3 " (4-to-Pica) " " . . . . .		
4 " (3-to-Pica) " " . . . . .		
6 " (Nonpareil) Slugs, per pound . . . . .		
8 " (Brevier) " " " . . . . .		
9 " (Bourgeois) " " " . . . . .		
10 " (Long Prim.) " " " . . . . .		
12 " (Pica) " " " . . . . .		
18 " (Great Prim.) " " " . . . . .		

Labor-Saving Leads and Slugs

12

2 Point or thicker, in fonts of graduated lengths, from 4 ems Pica and upward:

12 pound fonts . . . . .	\$3 00	50 pound fonts . . . . .	\$12 50
20 " " . . . . .	5 00	100 " " . . . . .	25 00
25 " " . . . . .	6 25	Sorts, per pound . . . . .	25

COPPER ALLOY TAKE SLUGS

15

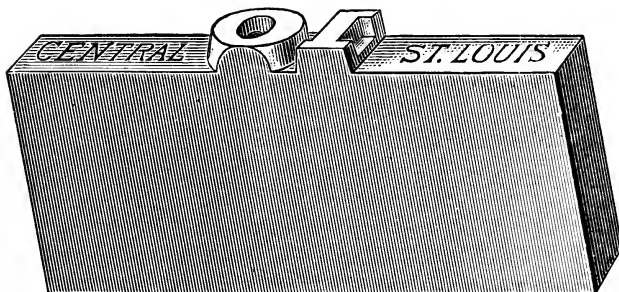

Price, each, 15 cents.

The only Take Slug cast in a mold in extra durable copper alloy metal. Better, cheaper and more durable than electrotyped slugs. Any number from 1 to 100, in this style of figure only:

**1 2 3 4 5 6 7 8 9 0**

Electrotyped (Word) Take Slugs

Price, each, 15 cents.

**METAL FURNITURE**

12

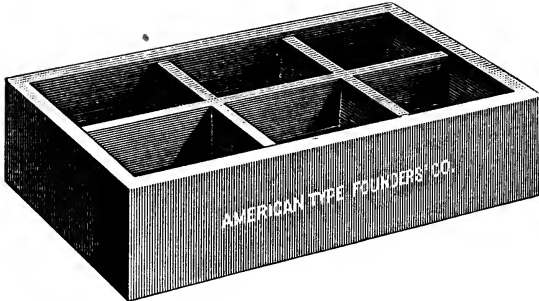

Put up in fonts containing the following sizes: 2, 3, 4, 5, 6, 8 and 10 ems Pica wide, and 4, 5, 6, 8, 10, 15, 20, 25, 30 and 50 ems Pica long.

12 pound font .	\$ 3 00
25 " " .	6 25
50 " " .	12 50
100 " " .	25 00

Sorts, 25 cents per lb.

Attention is invited to the new design of this furniture. The strain-bearing braces have been increased in number and placed in the best possible positions, increasing the strength while not increasing the weight.

**REVERSIBLE METAL FURNITURE**

12

This Labor-Saving Reversible Furniture is our invention, and is unsurpassed for its strength and accuracy. It is made on the Point System of Bodies, and is useful for making up and blanking out forms and for general imposition. It is cast in lengths of 16 1/2 inches, and 2, 3, 4, 5, 6, 8, 9 and 10 ems Pica wide, and is cut to such lengths as may be ordered. Not put up in fonts.

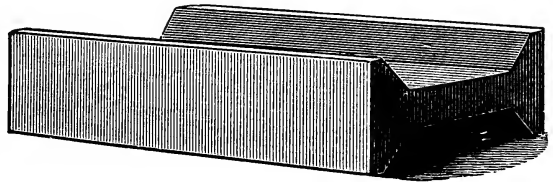

Price per pound, cut to measure, 25 cents.

**Labor-Saving Quotation Furniture**

12-15

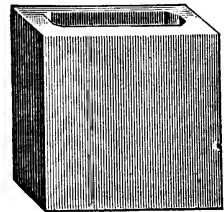
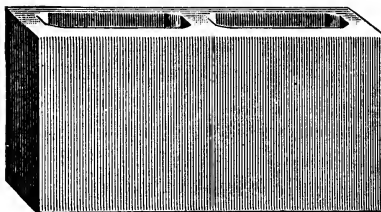

Finished with the strictest regard for accuracy. Made 2, 3 and 4 ems Pica wide, and 4, 8, 12, 16 and 20 ems Pica long.

12 pound fonts . . . . .	\$3 00	50 pound fonts . . . . .	\$12 50
25 " " . . . . .	6 25	100 " " . . . . .	25 00

Sorts, 25 cents per pound. Additional sizes, 2x5, 2x6, 3x5, 3x6, 4x5, 4x6, 5x5, 5x6, and 6x6, cast accurately to Pica ems, per pound, 25 cents.

COPPER ALLOY TYPE

ANGULAR QUADS

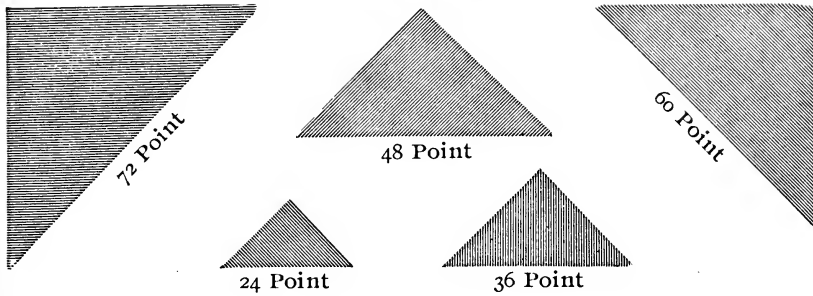

These quads, introduced by us, are for setting rules and lines at an angle. When there is occasion for their use they are invaluable time-savers. They are of ordinary space and quad height.

Fonts, four of all sizes. . . . .	\$1 50	36 Point, set of four . . . . .	\$0 25
12 Point, set of four . . . . .	20	48 " " " " . . . . .	30
18 " " " " . . . . .	20	60 " " " " . . . . .	35
24 " " " " . . . . .	20	72 " " " " . . . . .	40

CIRCULAR QUADS

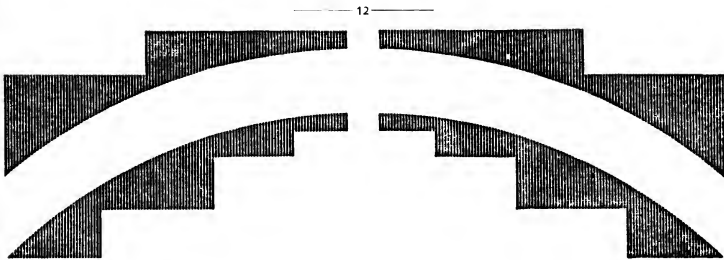

Each font is put up in a wooden box, containing four pieces each of twenty different curves. Each curve mortised as shown in examples above. Fonts, \$3 50.

CORNER QUADS

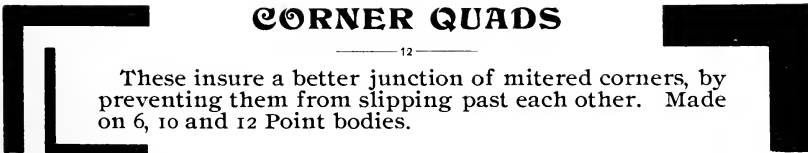

These insure a better junction of mitered corners, by preventing them from slipping past each other. Made on 6, 10 and 12 Point bodies.

Metal, 6, 10 or 12 Point, per set of four . . . . .	\$0 15
Brass, 3 Point, per set of four . . . . .	15

Where Accuracy is Most Needed.

Special attention is invited to the superior accuracy of our Metal and Quotation Furniture, illustrated on page 44. Purchasers of this material are insured against the annoyances and loss of time which result from the use of inferior products.

MUSIC TYPE

**Excelsior Music**

PER LB. \$3 60  
Weight of smallest font, 30 lbs.

**THE STAR-SPANGLED BANNER**

FRANCIS SCOTT KEY. 1814

*Voices in unison*

Oh, say, can you see, by the dawn's early light, What so proudly we hail'd at the

The image shows a musical score for 'The Star-Spangled Banner'. It consists of two staves. The first staff is in treble clef with a key signature of one flat (B-flat) and a 4/4 time signature. The second staff is in bass clef with the same key signature and time signature. The lyrics are written below the staves, with the first line of the score starting with 'Oh, say, can you see, by the dawn's early light, What so proudly we hail'd at the'.

**Excelsior Music No. 2**

PER LB. \$3 60  
Weight of smallest font, 30 lbs.

**MY COUNTRY! 'TIS OF THEE**

SAMUEL F. SMITH

H. CAREY

My country! 'tis of thee, Sweet land of lib - er - ty, Of thee I sing; Land where my

The image shows a musical score for 'My Country, 'Tis of Thee'. It consists of two staves. The first staff is in treble clef with a key signature of one flat (B-flat) and a 4/4 time signature. The second staff is in bass clef with the same key signature and time signature. The lyrics are written below the staves, with the first line of the score starting with 'My country! 'tis of thee, Sweet land of lib - er - ty, Of thee I sing; Land where my'.

*All fonts of Music Type are sold complete with Brass Rules accurately cut to match*



MUSIC TYPE

Excelsior Music No. 3

*Novello, or English Note*

PER LB. \$3 60  
Weight of smallest font, 30 lbs.

OLD HUNDRED

ISAAC WATTS

G. FRANC

Musical score for 'Old Hundred' in 4/4 time, G major. The score consists of two staves: a treble clef staff and a bass clef staff. The lyrics are: Be - fore Je - ho - vah's aw - ful throne, Ye na - tions! bow with sa - cred joy:

Diamond Music No. 1

PER LB. \$3 20  
Weight of smallest font, 60 lbs.

HOME, SWEET HOME

*With expression*

BISHOP

Musical score for 'Home, Sweet Home' in 2/4 time, D major. The score consists of two staves: a treble clef staff and a bass clef staff. The lyrics are: Mid pleas-ures and pal - a - ces though we may roam, Be it ev - er so

*The American Type Founders' Company is the only type-founding concern that makes a complete series of Music Type*

MUSIC TYPE

**Diamond Music No. 2**

PER LB. \$3 20  
Weight of smallest font, 60 lbs.

**ANNIE LAURIE**

*Tenderly*

Max - wel - ton's bracs are bon - nie, Where ear - ly fa's the dew,

The musical score for "Annie Laurie" consists of two systems of music. The first system is in treble clef with a 4/4 time signature and a key signature of one sharp (F#). It begins with a "Tenderly" dynamic marking. The melody is written on a single staff, and the lyrics "Max - wel - ton's bracs are bon - nie, Where ear - ly fa's the dew," are placed below the notes. The second system is in bass clef with a 4/4 time signature and a key signature of one sharp. It continues the melody from the first system.

**Diamond Music No. 3**

PER LB. \$3 20  
Weight of smallest font, 60 lbs.

**AULD LANG SYNE**

ROBERT BURNS

CHORUS.

For auld lang syne, my dear, For auld lang syne;  
For auld lang syne, my dear, For auld lang syne;

The musical score for "Auld Lang Syne" consists of two systems of music. The first system is in treble clef with a 4/4 time signature and a key signature of one sharp (F#). It begins with a "CHORUS." dynamic marking. The melody is written on a single staff, and the lyrics "For auld lang syne, my dear, For auld lang syne;" are placed below the notes. The second system is in bass clef with a 4/4 time signature and a key signature of one sharp. It continues the melody from the first system.

*The Music Types shown on this page, and on pages 46, 47, 49, and 50, are unexcelled examples of accurate type founding*

MUSIC TYPE

**Diamond Music No. 4**

*Novello, or English Note*

PER LB. \$3 20  
Weight of smallest font, 60 lbs.

Dear Fath - er - land, let peacc be thine, Dear Fath - er - land, let peacc be thine,

*ff*

Musical score for Diamond Music No. 4, featuring a treble and bass staff with lyrics: "Dear Fath - er - land, let peacc be thine, Dear Fath - er - land, let peacc be thine,". The score includes a dynamic marking of *ff* and repeat signs.

**Agate Music No. 3**

PER LB. \$2 40  
Weight of smallest font, 60 lbs.

*cantabile.*

Musical score for Agate Music No. 3, featuring a grand staff (treble and bass) with a dynamic marking of *mf* and a *cantabile.* instruction. The score includes a large brace over the first two staves and a repeat sign.

The list price of a set (three) of Music Cases is \$5.00. Our Wrought Iron Electrotype Chases are recommended to music printers on account of their trueness

### Nonpareil Music No. 3

PER. LB. \$2 00  
Weight of smallest font, 60 lbs.

SEYMOUR. 7S.

The first system of musical notation consists of two staves. The upper staff is in treble clef and the lower staff is in bass clef. Both staves are in 2/4 time and have a key signature of one flat (B-flat). The music is written in a style where notes are often beamed together in pairs or groups, and rests are used to indicate the timing of the notes. The first system contains six measures of music.

The second system of musical notation consists of two staves, continuing the piece from the first system. It maintains the same 2/4 time signature and one-flat key signature. The notation continues with beamed notes and rests, ending with a final double bar line and repeat dots.

The third system of musical notation consists of two staves, continuing the piece from the second system. It maintains the same 2/4 time signature and one-flat key signature. The notation continues with beamed notes and rests, ending with a final double bar line and repeat dots.

*Our Music Type is guaranteed to be mechanically accurate. Being cast in Copper Alloy Metal, the most durable type metal made, its wearing qualities are unsurpassed*



**PORSON GREEK**

8 POINT

JOB FONT \$7 50

Εἰ μὲν περὶ καινοῦ τινος πράγματος προὔτιθετο, φ ἄνδρες Ἀθηναῖοι, λέγειν, ἐπισχῶν ἂν ἕως οἱ πλείστοι τῶν εἰωθότων γνώμην ἀπεφήναντο, εἰ μὲν ἤρεσκέ τί μοι τῶν ὑπὸ τούτων ῥηθέντων, ἡσυχίαν ἂν ἤγον, εἰ δὲ μή, τότε ἂν αὐτὸς ἐπειρώμην ἅ γινώσκω λέγειν· ἐπειδὴ δὲ ὑπὲρ ὧν πολλάκις εἰρήκασιν οὗτοι πρότερον συμβαίνει καὶ νυνὶ σκοπεῖν, ἡγοῦμαι καὶ πρῶτος ἀναστὰς εἰκότως ἂν συγγνώμης τυγχάνειν. εἰ γὰρ ἐκ τοῦ παρεληλυθότος χρόνου τὰ δέοντα οὗτοι

*8 Point Porson Greek cast on 9 Point to order in fonts of 50 lbs. and upwards*

10 POINT

JOB FONT \$7 50

\* Ἄλλο δὲ στράτευμα αὐτῷ συνελέγετο ἐν Χερρονήσῳ τῆ καταντιπέρας Ἀβύδου τόνδε τὸν τρόπον. Κλέαρχος Λακεδαιμόνιος φυγὰς ἦν· τούτῳ συγγενόμενος ὁ Κῦρος ἠγάσθη τε αὐτὸν καὶ δίδωσιν αὐτῷ μυρίους δαρεικούς. ὁ δὲ λαβὼν τὸ χρυσίον στράτευμα συνέλεξεν ἀπὸ τούτων τῶν χρημάτων, καὶ ἐπολέμει ἐκ Χερρονήσου ὀρμώμενος τοῖς Θραξὶ τοῖς ὑπὲρ Ἑλλησποντον οἰκοῦσι, καὶ ὠφέλει τοὺς Ἕλληνας· ὥστε καὶ

11 POINT

JOB FONT \$7 50

\* Ἄλλο δὲ στράτευμα αὐτῷ συνελέγετο ἐν Χερρονήσῳ τῆ καταντιπέρας Ἀβύδου τόνδε τὸν τρόπον. Κλέαρχος Λακεδαιμόνιος φυγὰς ἦν· τούτῳ συγγενόμενος ὁ Κῦρος ἠγάσθη τε αὐτὸν καὶ δίδωσιν αὐτῷ μυρίους δαρεικούς. ὁ δὲ λαβὼν τὸ χρυσίον στράτευμα συνέλεξεν ἀπὸ τούτων τῶν χρημάτων, καὶ

12 POINT

JOB FONT \$7 50

\* Ἄλλο δὲ στράτευμα αὐτῷ συνελέγετο ἐν Χερρονήσῳ τῆ καταντιπέρας Ἀβύδου τόνδε τὸν τρόπον. Κλέαρχος Λακεδαιμόνιος φυγὰς ἦν· τούτῳ συγγενόμενος ὁ Κῦρος ἠγάσθη τε αὐτὸν καὶ δίδωσιν αὐτῷ μυρίους δαρεικούς. ὁ δὲ λαβὼν τὸ χρυσίον στράτευμα συνέλεξεν ἀπὸ

MINIMUM PRICE FOR SORTS, 75 CTS. NET

*See scheme, lay of cases, and other information on page 51*

## HEAVYFACE GREEK

8 POINT

JOB FONT \$7 50

Οὐκοῦν οὐδ' ἂν εἰς ἀντίποι  
ὡς οὐ συμφέρει τῇ πόλει καὶ  
Λακεδαιμονίους ἀσθενεῖς εἶναι  
καὶ Θηβαίους τούτουςι. Ἔστι  
τοῖνον ἔν τινι τοιούτῳ καιρῷ  
τὰ πράγματα νῦν, εἴ τι δεῖ  
τοῖς εἰρημένοις πολλάκις παρ'  
ὑμῖν λόγοις τεκμήρασθαι, ὥστε

κτείνω, f. κτενω̄ (§ 120, 1), a.  
ἐκτεινα (§ 121), pf. ἐκτανον  
(§ 109, 3) (ἀποκτείνω is gen-  
erally used), to kill.

Κύδνος, -ου, (ὀ), *Cydnus*, a  
river in Cilicia.

κύκλος, -ου, (ὀ), a circle; κύ-  
κλω, in a circle. Eng. CYCLE.

11 POINT

JOB FONT \$7 50

Βοηθήσαντες δὲ ἐς αὐτὸ Πασιτελίδας τε ὁ Λακε-  
δαιμόνιος ἄρχων καὶ ἡ παρούσα φυλακὴ προσβαλ-  
ήντων τῶν Ἀθηναίων ἡμύνοντο. καὶ ὡς ἐβιάζοντο  
καὶ αἱ νῆες ἅμα περιέπλεον ἐς τὸν λιμένα περιπεμ-  
φθεῖσθαι, δείσας ὁ Πασιτελίδας μὴ αἶ τε νῆες  
φθάσωσι λαβούσαι ἐρήμον τὴν πόλιν καὶ τοῦ τει-  
χίσματος ἀλισκομένου ἐγκαταληφθῆ, ἀπολιπὼν

## INSCRIPTION GREEK

10 POINT

30A \$4 80

ΡΗΞΑΝΤΑΨΙΡΑΦΥΛΛΞΑΝΤΑ  
ΠΑΝΛΥΡΑΦΥΛΛΞΑΝΤΑ  
ΤΑΜΙΕΥΞΑΝΤΑΔΕΚΑΠΤΕΥΞΑΝΤΑ↓  
ΓΡΑΜΜΑΤΕΥΞΑΝΤΑΚΑΙΤΗΦΙΛΟΣΕΒΑΣΤΟΥϕ  
ΓΕΡΟΥΞΙΑΣΚΑΙΤΩΝΦΙΛΟΣΕΒΑΣΤΩΝ  
ΝΕΨΗΝΚΑΙΡΩΜΑΙΨΗΝΥΠΠΟΣΧΟΜΕΝΟΝ  
ΚΑΙΕΙΞΤΗΝΑΛΟΡΑΝΚΙΟΝΑΣΕΙΚΟΞΙϕ  
ΞΚΟΥΤΛΩΣΑΝΤΑ□ΚΙΟΝΑΣΕΙΚΟΞΙ  
ΚΑΙΤΑΥΤΗΝΤΗΝΕΞΕ□ΡΑΝΑΝΤΟΥ□ΕΝΟΣ  
ΑΝΑϕΕΝΤΑΚΑΙΤΗΝΤΗΚΛΑΨΔΙΑΙΒΟΥΗΙ  
ϕΡΨΥΞΤΕΛΑΜΒΑΝΕΙΝΚΑΘΕΩ

MINIMUM PRICE FOR SORTS, 75 CTS. NET

*See scheme, lay of cases, and other information on page 51*





**\* HEBREW No. 1**

12 POINT

JOB FONT \$3 00

לְכָל זְמַן וְעַתָּה לְכָל־חֶפְזֵי תַחַת הַשָּׁמַיִם  
טוֹב יֵלֵךְ מִסֵּכֵן וְחֹכֵם מִמֶּלֶךְ זֶקֶן וְכֹסִיל

10 POINT

JOB FONT \$3 60

דִּבְרֵי קִהְלֹת בְּיַד־דָּוִד מֶלֶךְ בִּירוּשָׁלַם: הִבֵּל  
הַבָּלִים יֹאמֵר קִהְלֹת הַבָּל הַבָּלִים הַכֹּל הַבָּל:  
מִהִיתָרוֹן לְאָדָם בְּכָל־עֲמָלוֹ שִׁיעֲמַל תַּחַת

9 POINT

JOB FONT \$3 60

דִּבְרֵי קִהְלֹת בְּיַד־דָּוִד מֶלֶךְ בִּירוּשָׁלַם: הִבֵּל הַבָּלִים יֹאמֵר קִהְלֹת  
הִבֵּל הַבָּלִים הַכֹּל הַבָּל: מִהִיתָרוֹן לְאָדָם בְּכָל־עֲמָלוֹ שִׁיעֲמַל  
תַּחַת הַשָּׁמַשׁ: דוֹר הַלֵּךְ וְדוֹר בָּא וְהָאָרֶץ לְעוֹלָם עֲמַדַת: זוֹרַח  
הַשָּׁמַשׁ וּבָא הַשָּׁמַשׁ וְאֵל־מִקוֹמוֹ שׁוֹאֵף זוֹרַח הוּא שֵׁם: הוֹלֵךְ

8 POINT

JOB FONT \$3 60

דִּבְרֵי קִהְלֹת בְּיַד־דָּוִד מֶלֶךְ בִּירוּשָׁלַם: הִבֵּל הַבָּלִים יֹאמֵר קִהְלֹת הִבֵּל  
הַבָּלִים הַכֹּל הַבָּל: מִהִיתָרוֹן לְאָדָם בְּכָל־עֲמָלוֹ שִׁיעֲמַל תַּחַת הַשָּׁמַשׁ:  
דוֹר הַלֵּךְ וְדוֹר בָּא וְהָאָרֶץ לְעוֹלָם עֲמַדַת: זוֹרַח הַשָּׁמַשׁ וּבָא הַשָּׁמַשׁ וְאֵל־  
מִקוֹמוֹ שׁוֹאֵף זוֹרַח הוּא שֵׁם: הוֹלֵךְ אֶל־דְּרוֹם וְסוֹבֵב אֶל־צִפּוֹן סוֹבֵב

*This size supplied with or without Accented Letters, as required*

6 POINT

JOB FONT \$3 60

דִּבְרֵי קִהְלֹת בְּיַד־דָּוִד מֶלֶךְ בִּירוּשָׁלַם: הִבֵּל הַבָּלִים יֹאמֵר קִהְלֹת הִבֵּל הַבָּלִים  
הַכֹּל הַבָּל: מִהִיתָרוֹן לְאָדָם בְּכָל־עֲמָלוֹ שִׁיעֲמַל בְּסֵת הַשָּׁמַשׁ: דוֹר הַלֵּךְ  
וְדוֹר בָּא וְהָאָרֶץ לְעוֹלָם עֲמַדַת: זוֹרַח הַשָּׁמַשׁ וּבָא הַשָּׁמַשׁ וְאֵל־מִקוֹמוֹ  
שׁוֹאֵף זוֹרַח הוּא שֵׁם: הוֹלֵךְ אֶל־דְּרוֹם וְסוֹבֵב בְּעַרְנֵהאָרֶד הַעֲסֵסֵלְבֵעֵרַג

*\*Vowel Accents not included in fonts*

*With the exception of 8 Point, this series is suitable only for classical work*

**HEBREW No. 2**

*This series is not intended to be used with accents. It is the series commonly used for newspapers*

24 POINT

JOB FONT \$3 00

וויר האבען איינע זעהר רייכע  
אויסוואהל מאדערנער שריפט

18 POINT

JOB FONT \$2 50

מאטעריאליען פיר בוכדרוקערייען  
אויף לאגער אין אונזערען פיליאלען

12 POINT

JOB FONT \$2 50

אין דער ערסטען צייט דעם בוכדרוקעם ווארען דיא  
בוכדרוקער צוגלייך שריפטגועססער, בוכהענדלער אונד  
ניכט זעלטען אויך געלעהרטע. אללמעהליג בילדעטען

10 POINT

JOB FONT \$2 25

אין דער ערסטען צייט דעם בוכדרוקעם ווארען דיא דרוקער  
צוגלייך שריפטגועססער, בוכהענדלער אונד ניכט זעלטען  
אויך געלעהרטע. ערסט אללמעהליג בילדעטען זיך דיא

8 POINT

JOB FONT \$2 25

אין דער ערסטען צייט דעם בוכדרוקעם ווארען דיא בוכדרוקער צוגלייך שריפט-  
גועססער, בוכהענדלער אונד ניכט זעלטען אויך געלעהרטע. ערסט אללמעהליג  
בילדעטען זיך דיא בוכדרוקעריי אונד דיא שריפטגועססעריי אלס זעלבסטשטענדיגע  
געווערבע אויס, דאגעגען פינדעט זיך פערלעגער אונד בערנהארד העססעלבערג

**RABBINIC**

12 POINT

PER FONT \$11 80  
Font weighs 10 lbs.

מחיותי קורין את שוע צערצית. משעה שהכהנים נכנסים לאכול  
בתרומתן. עד סוף האשמורה הראשונה דצרי ר' אליעזר. ומכמים

10 POINT

PER FONT \$10 40  
Font weighs 8 lbs.

מחיותי קורין את שוע צערצית.  
משעה שהכהנים נכנסים לאכול  
בתרומתן. עד סוף האשמורה דצרי

8 POINT

PER FONT \$12 80  
Font weighs 8 lbs.

מחיותי קורין את שוע צערצית. משעה  
שהכהנים נכנסים לאכול בתרומתן. עד  
סוף האשמורה צערנהארד העססעלנצערג

**RUSSIAN No. 10**

12 POINT

PER LB. \$1 16  
Smallest font, 25 lbs.

ОБЩЕСТВО АМЕРИКАНСКИХЪ  
СЛОВОЛИТНИКОВЪ

Рекомендуетъ свой самый богатый складъ  
Англійскихъ, Нѣмецкихъ, Еврейскихъ и  
Грѣческихъ шрифтовъ, сдѣланныхъ изъ  
наилучшаго матеріала. Печатныя и бумаго-  
рѣзные машины и всякіе типографическіе

**ARMENIAN**

14 POINT

PER LB. \$1 12  
Smallest font, 25 lbs.

Երկու ամիս է որ քաղաքավիրթ ազ-  
գերն Հայաստանի վերայ վը խօսին

10 POINT

PER LB. \$1 30  
Smallest font 25 lbs.

Երկու ամիս է որ քաղաքակիրթ ազգերն Հայաս-  
տանի վերայ կը խօսին: Կրագրական սահմանէն

## Synopsis of Roman Faces

*All sizes are spaced uniformly with 3-to-em spaces*

---

### 3½ POINT MODERN ROMAN

Series No.

17—Printing was introduced into America at Mexico by the Viceroy Mendoza in 1536. The first book printed was the *Escala*

### 4½ POINT MODERN ROMAN

18—Printing was introduced into America at Mexico by the Viceroy Mendoza in 1536. The first book printed was the

17—Printing was introduced into America at Mexico by the Viceroy Mendoza in 1536. The first book printed

### 5 POINT MODERN ROMAN

67—Printing was introduced into America at Mexico by the Viceroy Mendoza in 1536. Th

57—Printing was introduced into America at Mexico by the Viceroy Mendoz

### 5½ POINT MODERN ROMAN

66—Printing was introduced into America at Mexico by the Viceroy Mendoza i

67—Printing was introduced into America at Mexico by the Viceroy Mendoza

65—Printing was introduced into America at Mexico by the Viceroy Mendoza

57—Printing was introduced into America at Mexico by the Viceroy Mend

53—Printing was introduced into America at Mexico by the Viceroy Mend

19½—Printing was introduced into America at Mexico by the Viceroy P

### 5½ POINT OLD STYLE ROMAN

80—Printing was introduced into America at Mexico by the Viceroy Mendoza i

73—Printing was introduced into America at Mexico by the Viceroy Men

### 6 POINT MODERN ROMAN

64—Printing was introduced into America at Mexico by the Viceroy Mend

65—Printing was introduced into America at Mexico by the Viceroy Mend

67—Printing was introduced into America at Mexico by the Viceroy Me

66—Printing was introduced into America at Mexico by the Viceroy Me

54—Printing was introduced into America at Mexico by the Viceroy M

60—Printing was introduced into America at Mexico by the Viceroy M

20½—Printing was introduced into America at Mexico by the Viceroy P

53—Printing was introduced into America at Mexico by the Viceroy I

57—Printing was introduced into America at Mexico by the Viceroy i

37½—Printing was introduced into America at Mexico by the Vice

68—Printing was introduced into America at Mexico by the Vice

### 6 POINT OLD STYLE ROMAN

71—Printing was introduced into America at Mexico by the Viceroy Mendoza in

\*—Printing was introduced into America at Mexico by the Viceroy Mendoz

84—Printing was introduced into America at Mexico by the Viceroy Me

83—Printing was introduced into America at Mexico by the Viceroy Me

72—Printing was introduced into America at Mexico by the Viceroy I

73—Printing was introduced into America at Mexico by the Viceroy

27—Printing was introduced into America at Mexico by the Vice

†—Printing was introduced into America at Mexico by the i

---

\*French Old Style No. 2. †Caxton Old Style.

---

## Synopsis of Roman Faces

*All sizes are spaced uniformly with 3-to-em spaces*

### 7 POINT MODERN ROMAN

Series No.

- 65—Printing was introduced into America at Mexico by the Viceroy S
- 66—Printing was introduced into America at Mexico by the Vicero
- 60—Printing was introduced into America at Mexico by the Vice
- 23½—Printing was introduced into America at Mexico by the Vice
- 67—Printing was introduced into America at Mexico by the Vic
- 57—Printing was introduced into America at Mexico by the Vic
- 53—Printing was introduced into America at Mexico by the V
- 68—Printing was introduced into America at Mexico by the V
- 38½—Printing was introduced into America at Mexico by tis

### 7 POINT OLD STYLE ROMAN

- 83—Printing was introduced into America at Mexico by the Vicer
- 84—Printing was introduced into America at Mexico by the Vicer
- \*—Printing was introduced into America at Mexico by the Vicer
- 72—Printing was introduced into America at Mexico by the Vic
- 73—Printing was introduced into America at Mexico by the Vi

### 8 POINT MODERN ROMAN

- ¶—Printing was introduced into America at Mexico by the Vicerti
- 60—Printing was introduced into America at Mexico by the V
- 64—Printing was introduced into America at Mexico by the V
- 65—Printing was introduced into America at Mexico by thei
- 67—Printing was introduced into America at Mexico by the
- 54—Printing was introduced into America at Mexico by th
- 57—Printing was introduced into America at Mexico by th
- 66—Printing was introduced into America at Mexico by th
- 18½—Printing was introduced into America at Mexico by th
- 53—Printing was introduced into America at Mexico by t
- 68—Printing was introduced into America at Mexico by
- 48½—Printing was introduced into America at Mexicos

### 8 POINT OLD STYLE ROMAN

- 71—Printing was introduced into America at Mexico by the Viceroy Me
- ‡—Printing was introduced into America at Mexico by the Vice
- \*—Printing was introduced into America at Mexico by the a
- 72—Printing was introduced into America at Mexico by the
- 83—Printing was introduced into America at Mexico by the
- 84—Printing was introduced into America at Mexico by th
- 22—Printing was introduced into America at Mexico by th
- †—Printing was introduced into America at Mexic

---

\*French Old Style No. 2.  
†Caxton Old Style.

‡French Elzevir No. 1.  
¶Century Roman.

## Synopsis of Roman Faces

*All sizes are spaced uniformly with 3-to-em spaces*

Series No.

### 9 POINT MODERN ROMAN

- ¶—Printing was introduced into America at Mexico by ths  
67—Printing was introduced into America at Mexico by th  
60—Printing was introduced into America at Mexico by ti  
65—Printing was introduced into America at Mexico by t  
53—Printing was introduced into America at Mexico by  
64—Printing was introduced into America at Mexico by  
57—Printing was introduced into America at Mexico b b  
32<sup>1</sup>/<sub>2</sub>—Printing was introduced into America at Mexicos

### 9 POINT OLD STYLE ROMAN

- 71—Printing was introduced into America at Mexico by the I  
72—Printing was introduced into America at Mexico bi  
83—Printing was introduced into America at Mexico b  
28—Printing was introduced into America at Mexico,

### 10 POINT MODERN ROMAN

- ¶—Printing was introduced into America at Mexico b  
65—Printing was introduced into America at Mexico i  
67—Printing was introduced into America at Mexico i  
54—Printing was introduced into America at Mexico  
60—Printing was introduced into America at Mexico  
64—Printing was introduced into America at Mexic  
57—Printing was introduced into America at Mexi  
17<sup>1</sup>/<sub>2</sub>—Printing was introduced into America at Mi

### 10 POINT OLD STYLE ROMAN

- 71—Printing was introduced into America at Mexico by i  
‡—Printing was introduced into America at Mexico bi  
29—Printing was introduced into America at Mexico,  
\*—Printing was introduced into America at Mexico  
72—Printing was introduced into America at Mexic  
84—Printing was introduced into America at Mexic  
83—Printing was introduced into America at Mex  
24—Printing was introduced into America at M  
†—Printing was introduced into America ati

---

\*French Old Style No. 2.  
†Caxton Old Style.

‡French Elzevir No. 1.  
¶Century Roman.

## Synopsis of Roman Faces

*All sizes are spaced uniformly with 3-to-em spaces*

### 11 POINT MODERN ROMAN

Series No.

- 60—Printing was introduced into America at Mexic  
67—Printing was introduced into America at Mex  
65—Printing was introduced into America at Met  
64—Printing was introduced into America at  
21<sup>1</sup>/<sub>2</sub>—Printing was introduced into America,

### 11 POINT OLD STYLE ROMAN

- 71—Printing was introduced into America at Mexico,  
84—Printing was introduced into America at Mei  
72—Printing was introduced into America at Me  
25—Printing was introduced into America at M  
83—Printing was introduced into America at

### 12 POINT MODERN ROMAN

- 60—Printing was introduced into America at i  
67—Printing was introduced into America at  
64—Printing was introduced into Americ,  
31<sup>1</sup>/<sub>2</sub>—Printing was introduced into America,

### 12 POINT OLD STYLE ROMAN

- 71—Printing was introduced into America at t  
‡—Printing was introduced into America ati  
72—Printing was introduced into America at  
84—Printing was introduced into America at  
\*—Printing was introduced into America a  
26—Printing was introduced into America  
83—Printing was introduced into Amerii  
†—Printing was introduced into Ameri

---

\*French Old Style No. 2. †Caxton Old Style. ‡French Elzevir No. 1.

**Time-Saving Mail List Type**

Every character is cast on en-quad (5 Point) set and only en-quads and 4-to-em spaces are used for spacing, but will be furnished on 4½ and 4 Points set when specially ordered. By setting sticks to a multiple of 10 Point, spacing and justification become mere child's play—in fact, this type is self-spacing. Although the face is large, on examination it will be found that Time-Saving Mail List Type is quite as condensed on the average as ordinary Mail List Type. Prices, same as for 10 Point Roman.

EXAMPLE, USED WITHOUT LOGOTYPES	EXAMPLE, IN COMBINATION WITH MAIL LIST LOGOTYPES No. 120 AND 10 POINT CLARENDON
Mershon Brothers 70Oct97 RAHWAY, N. Y.	<b>NEW YORK</b> Styles & Cash 26Jan91
John J. Blue 3Sep95	Trow's Pub. Co. 15Apr87
Henry Jackson 19Apr96 World Uptown Branch, NEW YORK, N. Y.	<b>PHILADELPHIA</b> George W. West 20Jul76
Theo.L.DeVinne 12Jan92 NEW YORK, N. Y.	Evening Bulletin 9Mar67 Ginn Pub. Co. 17Oct73

EXAMPLE, IN COMBINATION WITH MAIL LIST LOGOTYPES No. 122	EXAMPLE, IN COMBINATION WITH MAIL LIST LOGOTYPES No. 121, WITH 4-TO-EM FIGURES
Dr Chauncey Depew 3 Oct 91	♢William Grocker 12 Dec 95
Mrs Mary Walker 31 Mar 83	REV ♢James Parkhurst 9 Sep 87
Mr James J. Corbet 3 Jan 96	MISS ♢Fannie Davenport 6 Aug 90
Rev Abe Slupsky 30 Nov 98	HON ♢Patrick K. Mullane 2 June 92
James J. Blaine 3 Feb 89	REV ♢John B. Reed 14 Dec 65
Theo. Roosevelt 4 Apr 79	MRS ♢Bella Knowsall 22 May 99
Miss B. Hesselberg 3 Dec 95	HON ♢Robt. J. Ingersoll 30 Oct 86
Dr Dora Bloomer 12 May 95	MISS ♢Sarah Bernhardt 15 July 84

Mail List Type is put up in 50 and 100 pound fonts, with Logotypes, at regular rates for Roman letter. For 1000 names, with counties and states added, 100 pounds will be ample. Specimens of 8 and 9 Point Mail List Type, with Logotypes, sent on application.



COPPER ALLOY TYPE

MAIL LIST TYPE

12

10 POINT NO. 67 WITH MAIL LIST LOGOTYPES  
NO. 121 AND FIGURES ON 4-TO-EM SET

T Barney Reman 23 Sep 90  
Hon B F Elsmore 14 Aug 73  
Barton & Swift 22 Feb 83  
Rev R T Kennedy 18 Apr 85

**BOSTON**

Fountain & Sons 23 May 96  
Mrs Anna Elizabeth 27 Dec 81  
Padoga Tribune 23 July 92

*Logotypes on en-quad thickness*

10 POINT NO. 67 WITH MAIL LIST  
LOGOTYPES NO. 123

Rev Thos Brown 29 Sep 96  
Col Farmington 3 Nov 98  
Dr D R Brooks 31 Jan 96  
Racing Club Assn 4 May 97

**POLLIWIGVILLE**

Mis Lou Seymour 16 Jul 98  
Mas Willie Kemp 22 Aug 97  
Maj Cunningham 31 Dec 98

*Logotypes on en-quad thickness*

MAIL LIST LOGOTYPES

12-15

10 POINT EM SET NO. 120

Jan Feb Mar Apr May Jun Jul Aug Sep Oct Nov Dec

10 POINT EN SET NO. 121

Jan Feb Mar Apr May Jun July Aug Sep Oct Nov Dec  
Miss Mrs Hon 1234567890 Rev Dr Box

*Figures on 4-to-em set*

8 POINT EM SET NO. 150

Jan Feb Mar Apr May Jun Jul Aug Sep Oct Nov Dec

*Cast also on 9 Point em set body*

10 POINT EM SET NO. 122

Jan Feb Mar Apr May Jne July Aug Sep Oct Nov Dec 96 97

Mr Mrs Miss Box Dr Rev Esq

10 POINT EN SET NO. 123

Jan Feb Mar Apr May Jun Jul Aug Sep Oct Nov Dec 96 97 98  
Mr Mrs Miss Box Dr Rev Hon Eld Gen Col Maj

9 POINT EN SET NO. 150

Jan Feb Mar Apr May Jun Jul Aug Sep Oct Nov Dec

*Sold at Roman prices. May be used with any Series of Mail List Type*

AMERICAN TYPE FOUNDERS CO.

TABLE AND WHITEFACE FIGURES

These Figures are cast on en set. Lightface Figures are used for A. M. time, and Heavyface and Whiteface Figures for P. M. time

6 POINT WHITEFACE FIGURES NO. 2

PER LB. \$2 00

10 07	.....	<b>4.15</b>	0	Lv... LOUISVILLE... Ar	130	11 59	<b>10.30</b>	.....
11 10	6 43	<b>4.56</b>	74	..... Huntingburg .....	102	8 55	<b>7.46</b>	<b>6.38</b>
11 26	6 45	<b>5.14</b>	82	..... Ferdinand .....	98	8 40	<b>6.30</b>	<b>5.16</b>
11 36	6 58	<b>5.53</b>	85	..... Dale .....	95	7 30	<b>6.27</b>	<b>5.10</b>
11 45	7 17	<b>6.18</b>	88	..... Lincoln City.....	92	5 10	<b>4.42</b>	<b>3.45</b>
12 20	.....	<b>6.45</b>	94	..... Rockport Jct.....	88	5 02	<b>4.35</b>	<b>3.32</b>
12 24	7 20	.....	98	..... Gentryville .....	84	4 30	<b>3.28</b>	<b>2.43</b>
12 28	7 25	<b>8.52</b>	99	..... Pigeon .....	70	4 10	<b>3.16</b>	<b>2.32</b>
12 35	8 24	<b>9.57</b>	120	..... Tenneson .....	50	3 20	<b>2.90</b>	<b>1.30</b>
12 40	9 53	<b>10.30</b>	130	Ar..... EAMES .....	0	3 03	<b>2.20</b>	<b>1.10</b>

6 POINT TABLE FIGURES NO. 31

6 POINT TABLE FIGURES NO. 32

LIGHTFACE

PER LB. \$1 16

HEAVYFACE

<b>5 20</b>	<b>8 10</b>	7 09	0	Lv... LOUISVILLE... Ar	97	<b>5 49</b>	6 59	11 58
<b>5 35</b>	<b>8 23</b>	7 32	12	..... New Albany .....	66	<b>5 21</b>	6 30	11 30
<b>5 46</b>	<b>9 39</b>	8 21	19	..... Edwardsville.....	61	<b>4 42</b>	6 01	11 11
<b>7 50</b>	<b>9 40</b>	8 29	38	..... Georgetown.....	53	<b>4 10</b>	5 51	10 48
<b>5 30</b>	<b>10 12</b>	9 40	43	..... Crandall.....	51	<b>4 01</b>	5 12	10 26
<b>6 43</b>	<b>10 15</b>	9 59	69	..... Mott .....	40	<b>3 59</b>	4 48	10 00
<b>6 50</b>	<b>10 20</b>	10 14	73	..... Cordyon Junction..	34	<b>3 30</b>	4 24	9 12
<b>7 15</b>	<b>11 30</b>	10 25	78	..... Ramseys.....	22	<b>3 11</b>	3 43	9 34
<b>6 20</b>	<b>11 49</b>	10 34	93	..... Milltown .....	11	<b>2 30</b>	3 10	8 20
<b>7 40</b>	<b>11 58</b>	10 57	97	Ar..... MARENGO..... Lv	0	<b>2 12</b>	2 02	7 23

5½ POINT TABLE FIGURES NO. 31

5½ POINT TABLE FIGURES NO. 32

LIGHTFACE

PER LB. \$1 44

HEAVYFACE

5 50	11 45	<b>8 30</b>	0	Lv... PLEASANT HILL... Ar	69	5 50	<b>2 15</b>	<b>10 15</b>
6 15	<b>12 10</b>	<b>8 52</b>	10	..... Archie .....	59	5 25	<b>1 50</b>	<b>9 50</b>
6 43	<b>12 36</b>	<b>9 23</b>	23	..... Butler .....	56	4 57	<b>1 22</b>	<b>9 23</b>
6 56	<b>12 48</b>	<b>9 30</b>	29	..... Rich Hill.....	54	4 43	<b>1 09</b>	<b>9 10</b>
7 16	<b>1 10</b>	<b>9 58</b>	39	..... Nevada.....	50	4 22	<b>12 48</b>	<b>9 50</b>
.....	<b>1 31</b>	<b>10 21</b>	48	..... Nassau.....	48	.....	<b>12 29</b>	.....
7 40	<b>1 35</b>	<b>10 26</b>	50	..... Sheldon .....	39	3 55	<b>12 25</b>	<b>8 25</b>
8 01	<b>1 36</b>	<b>10 38</b>	52	..... Boston .....	29	3 50	<b>12 10</b>	<b>8 05</b>
8 14	<b>1 48</b>	<b>10 40</b>	56	..... Jasper .....	23	3 42	11 57	<b>7 52</b>
8 20	<b>1 53</b>	<b>10 46</b>	59	..... Carthage .....	10	3 15	11 52	<b>7 45</b>
8 41	<b>2 15</b>	<b>11 10</b>	69	Ar..... JOPLIN..... Lv	0	.....	11 30	<b>7 27</b>

5 POINT TABLE FIGURES NO. 31

5 POINT TABLE FIGURES NO. 32

LIGHTFACE

PER LB. \$1 80

HEAVYFACE

<b>9 22</b>	<b>2 30</b>	10 10	0	Lv... KANSAS CITY... Ar	43	<b>5 45</b>	<b>12 35</b>	7 20
<b>9 25</b>	<b>2 38</b>	10 17	1	..... Grand Avenue .....	39	<b>5 38</b>	<b>12 25</b>	7 12
<b>9 38</b>	<b>2 55</b>	10 30	6	..... Kansas City Junc .....	34	<b>5 25</b>	21 59	7 00
<b>9 49</b>	<b>3 05</b>	10 38	8	..... Centropolis .....	28	<b>5 18</b>	11 45	6 59
<b>9 52</b>	<b>3 18</b>	10 45	11	..... Leeds .....	25	<b>5 12</b>	11 42	6 41
<b>9 56</b>	<b>3 47</b>	11 00	18	..... Dodson .....	21	<b>4 56</b>	11 00	6 17
10 22	<b>4 05</b>	11 10	21	..... Red Bridge .....	18	<b>4 47</b>	10 38	5 00
10 31	<b>4 20</b>	11 19	25	..... Martin City.....	11	<b>4 37</b>	10 15	5 55
10 36	<b>4 32</b>	11 25	28	..... Newington .....	8	<b>4 32</b>	10 01	5 40
10 51	<b>5 00</b>	11	34	..... Stilwell .....	6	<b>4 15</b>	9 23	5 27
11 02	<b>5 21</b>	11 54	39	..... Wagstaff .....	1	<b>4 02</b>	8 58	5 11
11 11	<b>5 39</b>	<b>12 03</b>	43	Ar..... PAOLA..... Lv	0	<b>3 53</b>	8 33	5 07

COPPER ALLOY TYPE

TABLE AND WHITEFACE FIGURES

15

These Figures are cast on en set. Lightface Figures are used for A. M. time, and Heavyface and Whiteface Figures for P. M. time

8 POINT WHITEFACE FIGURES NO. 1				PER LB. \$1 60
1.00	10.20	5.30	Lv... KEOKUK ...Ar	9 46 11.19 2.45
4.50	.....	9.40	..... Fowler.....	6 00 ..... 11 06
5.35	4 00	9.50	..... Danville.....	4 72 11.00 10 06
5.53	4 09	10.06	..... Rome.....	..... 10.42 9 43
6 00	4 19	.....	..... Batavia.....	..... 10.30 9 33
6.17	4 28	.....	..... Ottumwa.....	..... 10.20 9 24
6.24	4 34	.....	..... Maxon.....	..... 10.10 9 18
6.40	4 46	10.40	..... Albia.....	3 47 9.55 9 67
6.50	4 49	.....	..... Russell.....	..... 9.40 8 76
7.02	6 10	11.02	..... Chariton.....	3 32 9.28 8 48
7.14	6 23	11.13	..... Lucas.....	..... 9.13 8 36
7.20	6 29	.....	Ar... MURRAY ...Lv	..... 9.07 8 08

8 POINT TABLE FIGURES NO. 31			PER LB. \$0 90	8 POINT TABLE FIGURES NO. 32		
LIGHTFACE				HEAVYFACE		
7 00	10 30	6 12	Lv... CHICAGO ...Ar	1 10	6 05	7 34
9 25	9 30	7 47	..... Galesburg.....	1 15	6 10	7 04
10 25	8 20	8 25	..... Abingdon.....	1 20	6 11	7 00
.....	.....	9 05	..... Avon.....	1 30	7 20	6 00
.....	6 45	9 20	..... Bushnell.....	1 35	7 27	4 49
11 57	7 05	9 35	..... Macom.....	1 40	7 45	4 30
.....	.....	9 50	..... Colmar.....	.....	7 54	4 26
12 40	7 40	10 12	..... Plymouth.....	2 48	7 55	4 19
.....	8 02	10 25	..... Augusta.....	.....	8 31	4 04
.....	8 20	10 40	..... La Prairie.....	.....	8 51	3 03
12 25	8 35	11 20	..... Goldon.....	12 13	9 05	3 30
.....	.....	11 32	Ar... MURRAY ...Lv	.....	9 30	3 17

7 POINT TABLE FIGURES NO. 31			PER LB. \$1 00	7 POINT TABLE FIGURES NO. 32		
LIGHTFACE				HEAVYFACE		
10 03	.....	7 00	Lv... ALTON.....Ar	6 05	3 45	8 10
10 30	6 30	8 10	..... St. Louis.....	5 29	3 10	7 30
10 38	6 45	8 20	..... Texas Junction...	5 06	2 45	7 05
10 43	8 15	8 30	..... Black Walnut.....	4 33	1 15	5 10
11 09	8 35	9 30	..... Marias Croche.....	3 50	12 55	4 50
11 17	10 15	10 25	..... Hamburg.....	3 35	12 10	4 00
11 33	.....	10 55	..... Defiance.....	3 14	11 25	3 55
11 43	.....	11 30	..... Matson.....	2 59	10 10	3 23
11 45	12 01	11 45	..... Augusta.....	2 36	9 50	3 01
11 58	12 10	1 10	..... Dutzow.....	2 26	9 37	2 51
1 13	.....	1 15	..... Marthasville.....	2 02	9 25	2 40
1 22	12 17	1 20	..... Holstein.....	1 40	9 14	2 31
1 28	.....	1 57	Ar... CAMERON ...Lv	1 33	9 03	2 20

## Description of Self Spacing Type

The common widths of book pages, miscellaneous jobs and newspaper columns are some number of Pica ems, therefore the Pica em is taken as the basis for Self Spacing type. The thinnest space in all fonts is some exact fraction of a Pica, and this fraction of Pica is called the unit of measure. All characters, spaces and quads in the font are made some exact multiple of this unit in width, so that the sizes of all faces will work perfectly together in the regular labor-saving measures. This unit of measure may be one-sixth, one-seventh, one-eighth, one-ninth, etc., of a Pica em, as may be desired, to produce condensed, medium or extended faces. The following table gives the sizes of bodies, units of measure and lengths of alphabets. In the first column will be found the various sizes of bodies; in the second, the number of units contained in one em Pica, and in the third the measurements of a lower case alphabet in the ems of each particular body.

BODY	Number Units to Pica em	Length of Alphabet
5½ Point (Agate).....	12	16⅞
6 Point (Nonpareil) .	12	15½
6 Point (Nonpareil) .	11	17
7 Point (Minion) .....	11	14½
7 Point (Minion) .....	10	16
8 Point (Brevier) .....	11	12⅝
8 Point (Brevier) .....	10	14⅞
8 Point (Brevier) .....	9	15½
9 Point (Bourgeois) .	10	12⅞
9 Point (Bourgeois) .	9	13¾
10 Point (Lg. Primer) )	9	12⅜
10 Point (Lg. Primer) )	8	14
11 Point (Small Pica) )	8	12⅔
11 Point (Small Pica) )	7	14½
12 Point (Pica).....	7	13¼

In the accompanying table will be found a Nonpareil with one-twelfth of Pica as the unit of measure. This is one-sixth of the body of Nonpareil, or the six-to-em space, and preserves in this particular font the old three-to-em space and the old en and em quads. The same is true of the Brevier on one-ninth, Bourgeois on one-eighth, and Pica on one-sixth of Pica. In a complete font of the old kind of body type there are about 190 widths of bodies. Appended is a table showing the

different widths of bodies of Self Spacing. It will be readily seen that there are but nine widths of bodies all told, and that the four-unit width predominates largely over any other, there being fifty-nine characters of this width. We omit the Italic characters from the table, as they go on the same widths of bodies and are interchangeable with the Roman:

1 unit—Space .....	1
2 units—Space, f i j l . ; , - ' ! I J '   .....	16
3 units—Quad, c e r s t z s z I J ? ( [ * † ‡ §    ¶ — ° .....	22
4 units—Quad, a b d g h k n o p q u v x y f i n f f \$ £ 1 2 3 4 5 6 7 8 9 0 A B C D E F G L N O P Q R T U V X Y & S Z .. - } { }   \ / .....	59
5 units—æ A B C D E F G L N O P Q R T U V Y H K M .....	21
6 units—Quad, m w œ w Æ œ f i f i H K X & t b ¶ @ — ... ¼ ½ ¾ ⅓ ⅔ ⅕ ⅜ ⅝ ⅞ .....	27
7 units—W M .....	2
8 units—Æ .....	2
12 units—Quad, .....	5
9 sizes.	
Roman characters.....	155
Italic characters.....	77
Total.....	232

COPPER ALLOY TYPE

Any compositor can see that no combination of units can be made that will not come within a certain number of exact units of filling a line. If a line of matter lacks, it must lack one or more exact units. Self Spacing type sets line for line with the ordinary Roman, where the lengths of the alphabets are the same. Repeated experiments with the new type have shown that the average compositor gains about twenty-five per cent. in speed, with no trouble in justification whatever. In the matter of the correction of proofs the gain is enormous. Say there is an "a" for an "e"; as "a" is four units wide and "e" three, "e" and one unit space justify the line perfectly. Even this measure of trouble is avoided in many instances. As twenty-eight of the most common lower case characters are of the same width, they can be substituted for one another without the change of a space. This type is of greater durability, as it is always on its feet and is therefore not worn by "pounding." In tabular work there is a great gain in speed and neatness. By the addition of a new character, viz: "|", it is easy to set perpendicular lines of any length, line upon line. It may be repeated that the compositor has nothing to learn in handling Self Spacing type. There is but one direction to be given—to set that which looks like the em quad (six unit quad) with the nick out. Whoever will study the principle on which Self Spacing type is based, will readily admit that it is bound to secure easy and perfect justification, greatly increased speed and consequent enormous saving, simplicity and rapidity of proof correction, and increased accuracy and ease in the setting of tables. All these points are beyond question, as certainly as the proposition that two and two are four is not open to argument. No rational person can

No. 1	No. 2	No. 3	No. 4	No. 5	No. 6	No. 7
i and	I HX	I DLE	s aturds	I MP	I dim	' DIN
s mit	I NK	s MIT	is thm	ui s NK	s mit	s MIT
b rot	S LY	B AIT	ne ver fr	b LY	B rot	S AIT
si tly	E LS	M ine	Th ursci	si LS	M tly	E RK
m an	H IE	LI ED	line forn	m IE	LI nd	H AD
su it;	SI SI	se ES	nine five	so IS	SE at	SI LS
no ts	NI X	PU ss	in cre asi	mi X	PA st	BI ts
No is	SA T	No is	comp oz	ME T	MA D	SU it
gl a d	FO Z	FLI T	Repea ti	gl a S	BIN S	FO x
mit e	OH I	SEA S	second r	snil I	SEA I	HO e
still i	\$34 !	NOT I	beat th	this I	NOT !	234 I

doubt them. This piece of composition was done in a 13-em measure stick, and set line upon line in the ordinary manner of straight reading matter, the lower part being leaded to show the method of setting. To further explain and illustrate the ease with which table work is done with Self Spacing type, we show above an example of

miscellaneous justifications, which is absolutely impossible to accomplish with the old kind of type. In column No. 1 the first line begins with the lower case "i", two units wide, which is followed by the upright dash "|", two units, and the characters "a", four units, "n", four units, "d", four units, comprising sixteen units to accurately fill the column. The second line begins with the letter "s", three units wide, which throws the space rule one unit further to the right than in the preceding line. In each succeeding line lower case characters are used to the total width of sixteen units, and such characters are chosen for the first part thereof as will admit of advancing the space rule to the right exactly one unit in each succeeding line.

In the other columns the same plan is followed, the only change being in the substitution of caps, small caps, figures, etc., for the lower case characters, all columns coming perfectly justified inside the perpendicular lines.

**Self Spacing Modern Roman**

— 3 —

5½ POINT NO. 19½



THE INVENTION OF PRINTING has always been recognized by educated men as a subject of importance: there is no mechanical art, nor are there any of the fine arts, about whose early history so many books have been written. The subject is as mysterious as it is inviting. There is an unusual *degree of obscurity* about the origin of the first printed books and the lives and works of the early printers. There are records and traditions which cannot be reconciled of at least three distinct inventions of printing. Its early history is entangled with a controversy about rival inventors which has lasted for more than three centuries, and is not yet fully determined. In the management of this controversy a subject intrinsically attractive has been made repulsive. The history of the invention of printing has been written to please national pride.

ABCDEFGHIJKLMN OPQRSTUVWXYZ

1234567890

Unit of measure of this font is 12 to Pica Lower case a to z, 16¾ ems

6 POINT NO. 20½



THE INVENTION OF PRINTING has always been recognized by educated men as a subject of importance: there is no mechanical art, nor are there any of the fine arts, about whose early history so many books have been written. The subject is as mysterious as it is inviting. There is an unusual degree of obscurity about the origin of the first printed books and the lives and works of the early printers. There are records and traditions which cannot be reconciled of at least three distinct inventions of printing. Its early history is *entangled with* a controversy about rival inventors which has lasted for more than three centuries, and is not yet fully determined. In the management of this controversy a subject intrinsically attractive has been made repulsive. The history

ABCDEFGHIJKLMN OPQRSTUVWXYZ

1234567890

Unit of measure of this font is 12 to Pica Lower case a to z, 15½ ems

6 POINT NO. 37½



THE INVENTION OF PRINTING has always been recognized by educated men as a subject of importance: there is no mechanical art, nor are there any of the fine arts, about whose early history so many books have been written. The subject is as mysterious as it is inviting. There is an *unusual degree* of obscurity about the origin of the first printed books and the lives and works of the early printers. There are records and traditions which cannot be reconciled of at least three distinct inventions of printing. Its early history is entangled with a controversy about rival inventors which has lasted for more than three centuries and is not yet fully determined. In the management of this controversy the subject is

ABCDEFGHIJKLMN OPQRSTUVWXYZ

1234567890

Unit of measure of this font is 11 to Pica Lower case a to z, 17 ems

## Self Spacing Modern Roman

7 POINT NO. 23½



THE INVENTION OF PRINTING has always been recognized by educated men as a subject of importance: there is no mechanical art, nor are there any of the fine arts, about whose early history so many books have been written. The subject is as mysterious as it is inviting. There is an *unusual degree of* obscurity about the origin of the first printed books and the lives and works of the early printers. There are records and traditions which cannot be reconciled of at least three distinct inventions of printing. Its early history is entangled with a controversy about rival invent-

ABCDEFGHIJKLMN OPQRSTUVWXYZ

1234567890

Unit of measure of this font is 11 to Pica Lower case a to z, 14½ ems

7 POINT NO. 38½



THE INVENTION OF PRINTING has always been recognized by educated men as a subject of importance: there is no mechanical art, nor are there any of the fine arts, about whose early history so many books *have been written*. The subject is as mysterious as it is inviting. There is an unusual degree of obscurity about the origin of the first printed books and the lives and works of the early printers. There are records and traditions which cannot be reconciled of at least three distinct inventions of printing. Its early history is entangled

ABCDEFGHIJKLMN OPQRSTUVWXYZ

1234567890

Unit of measure of this font is 10 to Pica Lower case a to z, 16 ems

8 POINT NO. 18½

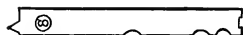

THE INVENTION OF PRINTING has always been recognized by educated men as a subject of importance: there is no mechanical art, nor are there any of the fine arts, about whose early history so many books have been written. The subject is as mysterious as it is inviting. There is an unusual degree of *obscurity about* the origin of the first printed books and the lives and works of the early printers. There are records and traditions which cannot be reconciled of at

ABCDEFGHIJKLMN OPQRSTUVWXYZ

1234567890

Unit of measure of this font is 10 to Pica Lower case a to z, 14¼ ems

**Self Spacing Modern Roman**

8 POINT NO. 48½

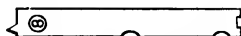

THE INVENTION OF PRINTING has always been recognized by educated men as a subject of importance: there is no mechanical art, nor are there any of the fine arts, *about whose early history* so many books have been written. The subject is as mysterious as it is inviting. There is an unusual degree of obscurity about the origin of the first printed books and the lives and works of the early printers. There are also

ABCDEFGHIJKLMNOPQRSTUVWXYZ

1234567890

Unit of measure of this font is 9 to Pica Lower case a to z, 15½ ems

9 POINT NO. 32½

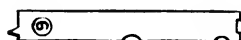

THE INVENTION OF PRINTING has always been recognized by educated men as a subject of importance: there is no mechanical art, nor are there any of the fine arts, *about whose early history* so many books have been written. *The subject is* as mysterious as it is inviting. There is an unusual degree of obscurity about the origin of the first printed books and the

ABCDEFGHIJKLMNOPQRSTUVWXYZ

1234567890

Unit of measure of this font is 9 to Pica Lower case a to z, 13¾ ems

10 POINT NO. 17½

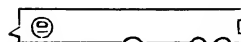

THE INVENTION OF PRINTING has always been recognized by educated men as a subject of importance: there is no *mechanical art*, nor are there any of the fine arts, *about whose early history* so many books have been written. The subject is as mysterious as it is inviting. There

ABCDEFGHIJKLMNOPQRSTUVWXYZ

1234567890

Unit of measure of this font is 8 to Pica Lower case a to z, 14 ems



## Self Spacing Modern Roman

11 POINT NO. 21½

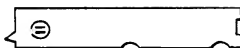

THE INVENTION OF PRINTING has always been recognized by educated men as a subject of importance: there is no mechanical art, nor any of the fine arts, about whose history so many books have been written. The subject is as mysterious as it is inviting. There is an *unusual degree* of obscurity about the origin of the first printed books and the lives and works of early printers. There are records and traditions which cannot be reconciled of at least three dis-

ABCDEFGHIJKLMN OPQRSTUVWXYZ

1234567890

Unit of measure of this font is 7 to Pica Lower case a to z, 14½ ems

12 POINT NO. 31½



THE INVENTION OF PRINTING has always been recognized by educated men as a subject of importance: there is no mechanical art, nor any of the fine arts, about whose history so *many books* have been written. The subject is as mysterious as it is inviting. There is an unusual degree of obscurity about the origin of the first printed books and the lives and works of early printers. There are records and traditions which

ABCDEFGHIJKLMN OPQRSTUVWXYZ

1234567890

Unit of measure of this font is 7 to Pica Lower case a to z, 13¼ ems

**Self Spacing Old Style Roman**

6 POINT NO. 27



THE INVENTION OF PRINTING has always been recognized by educated men as a subject of importance: there is no mechanical art, nor are there any of the fine arts, about whose early history so many books have been written. The subject is as mysterious as it is inviting. There is an *unusual degree* of obscurity about the origin of the first printed books and the lives and works of early printers. There are records and traditions which cannot be reconciled of at least three distinct inventions of printing. Its early history is entangled with a controversy about rival inventors which has lasted for more than three centuries, and is not yet fully determined. In the management of this controversy a subject in

ABCDEFGHIJKLMN OPQRSTUVWXYZ

1234567890

Unit of measure of this font is 11 to Pica Lower case a to z, 17 ems

8 POINT NO. 22

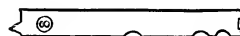

THE INVENTION OF PRINTING has always been recognized by educated men as a subject of importance: there is no mechanical art, nor are there any of the fine arts, about whose early history so *many books* have been written. The subject is as mysterious as it is inviting. There is an unusual degree of obscurity about the origin of the first printed books and the lives and works of the early printers. There are records and traditions which cannot be reconciled of at

ABCDEFGHIJKLMN OPQRSTUVWXYZ

1234567890

Unit of measure of this font is 10 to Pica Lower case a to z, 14½ ems

9 POINT NO. 28

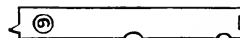

THE INVENTION OF PRINTING has always been recognized by educated men as a subject of importance: there is *no mechanical art*, nor are there any of the fine arts, about whose early history so many books have been written. The subject is as mysterious as it is inviting. There is an unusual degree of obscurity about the origin of the first printed books and the

ABCDEFGHIJKLMN OPQRSTUVWXYZ

1234567890

Unit of measure of this font is 9 to Pica Lower case a to z, 13¾ ems

## Self Spacing Old Style Roman

10 POINT No. 29

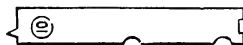

THE INVENTION OF PRINTING has always been recognized by educated men as a subject of importance: there is no mechanical art, nor are there any of the fine arts, about whose early history so many books have been written. The subject is as mysterious as it is inviting. There is an *unusual degree* of obscurity about the origin of the first printed books and the lives and works of early printers. There are records and traditions which cannot be reconciled of at least three distinct inventions of printing. Its early history is entangled with a controversy about rival inventors which has lasted for more than three centuries, and is

ABCDEFGHIJKLMN OPQRSTUVWXYZ

1234567890

Unit of measure of this font is 9 to Pica Lower case a to z, 12 $\frac{3}{8}$  ems

10 POINT No. 24

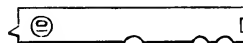

THE INVENTION OF PRINTING has always been recognized by educated men as a subject of importance: there is no mechanical art, nor are there any of the fine arts, about whose early history so many books have been written. The subject is as mysterious as it is inviting. There is an *unusual degree of obscurity* about the origin of the first printed books and the lives and works of the early printers. There are records and traditions which cannot be reconciled of at least three distinct inventions of printing. Its early history is entangled with a controversy about rival inventors which has lasted for more

ABCDEFGHIJKLMN OPQRSTUVWXYZ

1234567890

Unit of measure of this font is 8 to Pica Lower case a to z, 14 ems

**Self Spacing Old Style Roman**

11 POINT No. 25



THE INVENTION OF PRINTING has always been recognized by educated men as a subject of importance: there is no mechanical art, nor are there any of the fine arts, about whose early history so many books have been written. The subject is as mysterious as it is inviting. There is an unusual degree of obscurity about the origin of the *first printed books* and the lives and works of the early printers. There are records and traditions which cannot be reconciled of at least three distinct inventions of printing. Its

ABCDEFGHIJKLMNOPQRSTUVWXYZ

1234567890

Unit of measure of this font is 8 to Pica Lower case a to z, 12 $\frac{2}{3}$  ems

12 POINT No. 26



THE INVENTION OF PRINTING has always been recognized by educated men as a subject of *importance*: there is no mechanical art, nor any of the fine arts, about whose history so many books have been written. The subject is as mysterious as it is inviting. There is an unusual degree of obscurity about the origin of the first printed books and the lives and works of early printers. There are records and traditions which

ABCDEFGHIJKLMNOPQRSTUVWXYZ

1234567890

Unit of measure of this font is 7 to Pica Lower case a to z, 13 $\frac{1}{4}$  ems

**Self Spacing Old Style Italic**

3

6 POINT NO. 27 Circular Font \$7 00

*The Invention of Printing has always been recognized by educated men as a subject of great importance: there is no mechanical art, nor are* \$123456

ABCDEFGHIJKLMN**OP**QRST

8 POINT NO. 22 Circular Font \$5 40

*The Invention of Printing has always been recognized by educated men as a subject of importance: \$1234567*

ABCDEFGHIJKLMN**OP**QR

9 POINT NO. 28

Circular Font \$4 80

*The Invention of Printing has always been recognized by educated men as a subject of importance: there is no mechanical art, nor are there any \$12345*

ABCDEFGHIJKLMN**OP**QRSTUVWXYZ

10 POINT NO. 29

Circular Font \$4 45

*The Invention of Printing has always been recognized by educated men as a subject of importance: there is no mechanical art, nor are there any \$12345*

10 POINT NO. 24

Circular Font \$4 45

*The Invention of Printing has always been recognized by educated men as a subject of great importance: there is no mechanical art \$12345*

ABCDEFGHIJKLMN**OP**QRSTUVWXYZ

11 POINT NO. 25

Circular Font \$4 20

*The Invention of Printing has always been recognized by educated men as a subject of importance: there is no mechanical art \$12345*

ABCDEFGHIJKLMN**OP**QRSTUVWXYZ

12 POINT NO. 26

Circular Font \$3 95

*The Invention of Printing has always been recognized by educated men as a subject of importance: there is no \$123456*

ABCDEFGHIJKLMN**OP**QRSTUVWXYZ

*Spaces and Quads are included with each font*

**Self Spacing Old Style Bold**

---

8 POINT

30A 50a \$3 30

**THE INVENTION OF PRINTING HAS**

Always been recognized by educated men as a subject of importance: there is no mechanical art, nor are there any of the fine arts, about whose early history so much has \$1234567890

9 POINT

28A 45a \$3 35

**THE INVENTION OF PRINTING**

Has always been recognized by educated men as a subject of importance: there is no mechanical art, nor are there any of the fine arts, about whose early his \$1234567890

10 POINT

25A 40a \$3 50

**THE INVENTION OF PRINTING**

Has always been recognized by educated men as a subject of importance: there is no mechanical art nor are there any of the fine arts, about \$12345678

12 POINT

25A 38a \$4 00

**INVENTION OF PRINTING**

Has always been recognized by educated men as a subject of importance: there is no \$1234567

8 POINT IN COMBINATION WITH 8 POINT SELF SPACING OLD STYLE NO. 122

This Series of Old Style Bold was cut after many inquiries for a Job face that could be used with Self Spacing to emphasize certain words. All sizes shown above will line with Self Spacing Type.

COPPER ALLOY TYPE

SELF SPACING PIECE FRACTIONS

*These fonts are supplied with spaces, and can be used with ordinary as well as Self Spacing type*

12 POINT ROMAN No. 31 PER FONT \$2 50  
~~3~~1~~2~~/~~16~~ 1234 ~~1~~~~2~~/~~3~~~~4~~ 1/2 2/3 3/4 4/5 ~~5~~~~6~~/~~7~~~~8~~ 5678

11 POINT ROMAN No. 21 PER FONT \$2 50  
~~5~~3/16 1234 ~~1~~~~2~~/~~3~~~~4~~ 1/4 2/3 3/4 1/16 ~~5~~~~6~~/~~7~~~~8~~ 5678

10 POINT ROMAN No. 17 PER FONT \$2 50  
~~2~~1~~2~~/~~8~~ 12345 ~~1~~~~2~~/~~3~~~~4~~~~5~~ 2/7 5/6 4/5 7/8 ~~6~~~~7~~~~8~~~~9~~ 67890

9 POINT ROMAN No. 32 PER FONT \$2 50  
~~7~~1/16 12345 ~~1~~~~2~~/~~3~~~~4~~~~5~~ 1/9 3/8 2/7 5/6 1/5 7/8 ~~6~~~~7~~~~8~~~~9~~ 67890

8 POINT ROMAN No. 18 PER FONT \$2 50  
~~3~~2~~1~~/~~3~~~~2~~ 12345 ~~1~~~~2~~/~~3~~~~4~~~~5~~ 2/7 5/6 3/4 7/8 5/9 1/6 5/8 ~~6~~~~7~~~~8~~~~9~~ 67890

7 POINT ROMAN No. 23 PER FONT \$2 50  
~~2~~3~~1~~~~5~~/~~6~~~~4~~ 12345 ~~1~~~~2~~/~~3~~~~4~~~~5~~ 1/2 2/7 1/5 3/5 1/6 5/7 5/8 7/8 ~~5~~~~6~~~~7~~~~8~~~~9~~ 567890

6 POINT ROMAN No. 20 PER FONT \$2 50  
~~3~~9~~1~~/~~1~~~~5~~~~7~~ 12345 ~~1~~~~2~~/~~3~~~~4~~~~5~~ 1/6 3/8 2/7 5/6 1/5 3/4 2/5 1/2 5/8 7/8 ~~5~~~~6~~~~7~~~~8~~~~9~~ 567890

12 POINT OLD STYLE No. 26 PER FONT \$2 50  
~~3~~2/43 12345 ~~1~~~~2~~/~~3~~~~4~~~~5~~ 1/2 2/3 3/4 ~~1~~~~2~~~~3~~~~4~~~~5~~ 12345

11 POINT OLD STYLE No. 25 PER FONT \$2 50  
~~7~~2/43 12345 ~~1~~~~2~~/~~3~~~~4~~~~5~~ 1/2 2/3 4/5 1/16 ~~1~~~~2~~~~3~~~~4~~~~5~~ 12345

10 POINT OLD STYLE No. 24 PER FONT \$2 50  
~~5~~3/87 12345 ~~6~~~~7~~/~~6~~~~9~~~~0~~ 2/7 5/6 3/4 7/8 ~~1~~~~2~~~~3~~~~4~~~~5~~ 12345

9 POINT OLD STYLE No. 28 PER FONT \$2 50  
~~5~~10/32 12345 ~~1~~~~2~~/~~3~~~~4~~~~5~~ 1/4 3/4 1/5 2/5 3/5 4/5 ~~1~~~~2~~~~3~~~~4~~~~5~~ 12345

8 POINT OLD STYLE No. 22 PER FONT \$2 50  
~~2~~5~~1~~~~5~~/~~3~~~~2~~ 12345 ~~1~~~~2~~/~~3~~~~4~~~~5~~ 1/4 1/2 3/4 1/5 2/5 4/5 1/7 ~~1~~~~2~~~~3~~~~4~~~~5~~ 12345

6 POINT OLD STYLE No. 27 PER FONT \$2 50  
~~4~~6~~1~~/~~3~~~~5~~~~7~~ 12345 ~~1~~~~2~~/~~3~~~~4~~~~5~~ 1/4 3/4 1/5 2/5 3/5 1/7 3/7 5/7 1/8 ~~1~~~~2~~~~3~~~~4~~~~5~~ 12345

**SELF SPACING GERMAN**

6 POINT NO. 42



Auf keinem Gebiete waren die Fortschritte seit vier Jahrhunderten so gering wie in der Kunst des Schriftsetzens. Die hier und da in Gebrauch befindlichen Maschinen sind durchaus unvollkommen; die bei weitem größte Masse der üblichen Schrift ist noch genau der Art wie vor vierhundert Jahren. Wenn Franklin heute wieder vor dem Kasten stände, würde er nichts Neues zu lernen haben. Die Schriftgießerei ist hinter der wunderbaren Vervollkommnung der Pressen vollständig zurückgeblieben; die vergrößerte Geschwindigkeit im Schriftsetzen beruht ausschließlich in der Vermehrung der Kästen. Alle Bemühungen, diesem Übelstande abzuhelpfen, gingen darauf hinaus, Setzmaschinen zu erfinden, statt die Art und Weise des Handsetzens zu verbessern. Eins der Haupthindernisse, welches den Setzmaschinen im Wege stand, ist die Nothwendigkeit, mit der Hand zu „justiren“. Daran scheiterte hauptsächlich die Einführung dieser Maschinen. Es liegt daher auf der Hand, daß jeder Plan zur Verbesserung unserer Setz-Methoden in erster Linie die Justirung zu vereinfachen hat, denn da dies der Punkt ist, um den sich die Sache dreht, so muß durch eine Vereinfachung des Ausschließens und Justirens die Leichtigkeit und Geschwindigkeit des Hand-Schriftsetzens wachsen. Dies geschieht durch Benton's selbst-ausschließende Schrift. Genau genommen, kann man nicht eigentlich von Selbst-Ausschließen sprechen, jedoch diese Arbeit ist durch die Erfindung so einfach und leicht geworden, daß der

ABCDEFGHIJKLMNOPQRSTUVWXYZ

1234567890

Unit of measure of this font is 12 to Pica Lower case a to z, 15 ems

8 POINT NO. 43

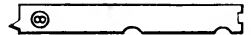

Auf keinem Gebiete waren die Fortschritte seit vier Jahrhunderten so gering wie in der Kunst des Schriftsetzens. Die hier und da in Gebrauch befindlichen Maschinen sind durchaus unvollkommen; die bei weitem größte Masse der üblichen Schrift ist noch genau der Art wie vor vierhundert Jahren. Wenn Franklin heute wieder vor dem Kasten stände, würde er nichts Neues zu lernen haben. Die Schriftgießerei ist hinter der wunderbaren Vervollkommnung der Pressen vollständig zurückgeblieben; die vergrößerte Geschwindigkeit im Schriftsetzen beruht ausschließlich in der Vermehrung der Kästen. Alle Bemühungen, diesem Übelstande abzuhelpfen, gingen darauf hinaus, Setzmaschinen zu erfinden, statt die Art und Weise des Handssetzens zu verbessern. Eins der Haupthindernisse, welches den Setzmaschinen im Wege stand, ist die Nothwendigkeit, mit der Hand zu „justiren“. Daran scheiterte hauptsächlich die Einführung dieser Maschinen. Es liegt daher auf der Hand, daß jeder Plan zur Verbesserung unserer Setz-Methoden in erster Linie die Justirung zu

ABCDEFGHIJKLMNOPQRSTUVWXYZ

1234567890

Unit of measure of this font is 11 to Pica Lower case a to z, 12¼ ems



## SELF SPACING GERMAN

9 POINT NO. 41



Auf keinem Gebiete waren die Fortschritte seit vier Jahrhunderten so gering wie in der Kunst des Schriftsetzens. Die hier und da in Gebrauch befindlichen Maschinen sind durchaus unvollkommen; die bei weitem größte Masse der üblichen Schrift ist noch genau der Art wie vor vierhundert Jahren. Wenn Franklin heute wieder vor dem Kasten stände, würde er nichts Neues zu lernen haben. Die Schriftgießerei ist hinter der wunderbaren Vervollkommnung der Pressen vollständig zurückgeblieben; die vergrößerte Geschwindigkeit im Schriftsetzen beruht ausschließlich in der Vermehrung der Kästen. Alle Bemühungen, diesem Übelstande abzuhelpfen, gingen darauf hinaus, Setzmaschinen zu erfinden, statt die Art und Weise des Handsetzens zu verbessern. Eins der Hindernisse, welches den Setzmaschinen im Wege stand, ist die Nothwendigkeit, mit

A B C D E F G H I J K L M N O P Q R S T U V W X Y Z

1234567890

Unit of measure of this font is 10 to Pica Lower case a to z, 12 ems

10 POINT NO. 40



Auf keinem Gebiete waren die Fortschritte seit vier Jahrhunderten so gering wie in der Kunst des Schriftsetzens. Die hier und da in Gebrauch befindlichen Maschinen sind durchaus unvollkommen; die größte Masse der üblichen Schrift ist noch genau der Art wie vor vierhundert Jahren. Wenn Franklin heute wieder vor dem Kasten stände, würde er nichts Neues zu lernen haben. Die Schriftgießerei ist hinter der wunderbaren Vervollkommnung der Pressen vollständig zurückgeblieben; vergrößerte Geschwindigkeit im Schriftsetzen beruht ausschließlich in der Vermehrung der Kästen. Alle Bemühungen, diesem Übelstande abzuhelpfen, gingen darauf hinaus, Setzmaschinen zu erfinden, statt die Art

A B C D E F G H I J K L M N O P Q R S T U V W X Y Z

1234567890

Unit of measure of this font is 9 to Pica Lower case a to z, 12 ems

AMERICAN TYPE FOUNDERS CO.

3½ POINT NO. 17

THE INVENTION OF PRINTING has always been recognized by educated men as a subject of importance: there is no mechanical art, nor are there any of the fine arts, about whose early history so many volumes have been written. The subject is as mysterious as it is inviting. There is an unusual degree of obscurity about the origin of the first printed books and the lives and works of the early printers. There are records and traditions which cannot be reconciled of at least three distinct inventions of printing. Its early history is entangled with a controversy about rival inventors which has lasted for more than three centuries, and is not yet fully determined. In the management of this controversy, a subject intrinsically attractive has been made repulsive. The history of the invention of printing has been written to please national pride. German authors assert the claims of Gutenberg and discredit traditions about Coster. Dutch authors insist on the priority of Coster and charge Gutenberg with stealing the invention. Partisans on each side say that their opponents have perverted the records and suppressed the truth. The quarrel has spread. English and French authors who had no national prejudices to gratify, and who should have considered the question without passion, have wrangled over the subject with all the bitterness of Germans or Hollanders. In this, as in other quarrels, there are amusing features, but to the general reader the controversy seems unfortunate and is certainly wearisome. It is a greater misfortune that all the early chronicles of printing were written in a dead language. Wolf's collection of Typographic Monuments, which includes nearly every paper of value written before 1740, is in Latin; the valuable books of Meerman, Maittaire, and Schoepflin are also in Latin. To the general reader these are sealed books, so the student who seeks exact knowledge of the methods of the first printers, they are tiresome books. Written for the information of librarians rather than of printers, it is but proper that these books should devote the largest space to a review of the controversy or to a description of early editions; but it is strange that they should so imperfectly describe the construction and appearance of early types and the usages of the early printers. The mechanical features of typography were, apparently, neglected as of little importance, and beneath the dignity of history. Failure to

ABCDEFGHIJKLMNQRSTUWXYZ  
1234567890

CARD FONT, 2 LBS. \$10 00

4½ POINT NO. 17

THE INVENTION OF PRINTING has always been recognized by educated men as a subject of importance: there is no mechanical art, nor are there any of the fine arts, about whose early history so many volumes have been written. The subject is as mysterious as it is inviting. There is an unusual degree of obscurity about the origin of the first printed books and the lives and works of the early printers. There are records and traditions which cannot be reconciled of at least three distinct inventions of printing. Its early history is entangled with a controversy which has lasted for more than three centuries, and is not yet fully determined. In the management of this controversy, a subject intrinsically attractive has been made repulsive. The history of the invention of printing has been written to please national pride. German authors assert the claims of Gutenberg and discredit traditions about Coster. Dutch authors insist on the priority of Coster and charge Gutenberg with stealing the invention. Partisans on each side say that their opponents have perverted the records and suppressed the truth. The quarrel has spread. English and French authors who had no national prejudices to gratify, and who should have considered the question without passion, have wrangled over the subject with all the bitterness of Germans or Hollanders. In this, as in other quarrels, there are amusing features, but to the general reader the controversy seems unfortunate and is certainly wearisome. It is a greater misfortune that all the early chronicles of printing were written in a dead language. Wolf's collection of Typographic Monuments, which in-

ABCDEFGHIJKLMNQRSTUWXYZ  
1234567890

CARD FONT, 3 LBS. \$7 50

4½ POINT NO. 18

THE INVENTION OF PRINTING has always been recognized by educated men as a subject of importance: there is no mechanical art, nor are there any of the fine arts, about whose early history so many books have been written. The subject is as mysterious as it is inviting. There is an unusual degree of obscurity about the origin of the first printed books and the lives and works of the early printers. There are records and traditions which cannot be reconciled of at least three distinct inventions of printing. Its early history is entangled with a controversy about rival inventors which has lasted for more than three centuries, and is not yet fully determined. In the management of this controversy, a subject intrinsically attractive has been made repulsive. The history of the invention of printing has been written to please national pride. German authors assert the claims of Gutenberg and discredit traditions about Coster. Dutch authors insist on the priority of Coster and charge Gutenberg with stealing the invention. Partisans on each side say that their opponents have perverted the records and suppressed the truth. The quarrel has spread. English and French authors who had no national prejudices to gratify, and who should have considered the question without passion, have wrangled over the subject with all the bitterness of Germans and Hollanders. In this, as in other quarrels, there are amusing features, but to the general reader the controversy seems unfortunate and is certainly wearisome. It is a greater misfortune that all the early chronicles of printing were written in a dead language. Wolf's collection of Typographic Monuments, which includes nearly every paper of value written before 1740, is in Latin; the valuable books of Meerman, Maittaire and Schoepflin are also in Latin. To the general reader these are sealed books;

ABCDEFGHIJKLMNQRSTUWXYZ  
1234567890

CARD FONT, 3 LBS. \$10 50

★ 5 POINT NO. 67

THE INVENTION OF PRINTING has always been recognized by educated men as a subject of importance: there is no mechanical art, nor are there any of the fine arts about whose history so many books have been written. The subject is as mysterious as it is inviting. There is an unusual degree of obscurity about the origin of the first printed books and the lives and works of the early printers. There are records and traditions which cannot be reconciled of at least three distinct inventions of printing. Its early history is entangled with a controversy about rival inventors which has lasted for more than three centuries, and is not yet fully determined. In the management of this controversy, an intrinsically attractive subject has been made repulsive. The history of the invention of printing has been written to please public pride. German authors assert the claims of Gutenberg and discredit traditions about Coster. Dutch authors must insist on the priority of Coster and charge Gutenberg with stealing the invention. Partisans on each side say their opponents have perverted the records and suppressed the real truth. The quarrel has spread. English and French authors who had no national prejudices to gratify, and who should have

ABCDEFGHIJKLMNQRSTUWXYZ  
1234567890

CARD FONT, 6 LBS. \$10 80

COPPER ALLOY TYPE

---

6 POINT NO. 54

THE INVENTION OF PRINTING has always been recognized by educated men as a subject of great importance: there is no mechanical art, nor are there any of the fine arts, about whose early history so many volumes have been written. The subject is as mysterious as it is inviting. There is an unusual degree of obscurity about the origin of the first printed books and the lives and works of the early printers. There are records and traditions which cannot be reconciled of at least three distinct inventions of printing. Its *early history* is entangled with a controversy about rival inventors which has lasted for more than three centuries, and is not yet fully determined. In the management of this controversy, a subject intrinsically attractive has been made repulsive. The history of the invention of printing has been written to please national pride. German

Lower case a to z, 15 $\frac{2}{3}$  ems

ABCDEFGHIJKLMNOPQRSTUVWXYZ  
1234567890

8 POINT NO. 54

THE INVENTION OF PRINTING has always been recognized by educated men as a subject of great importance: there is no mechanical art, nor are there any of the fine arts, about whose early history so many volumes have been written. The subject is as *mysterious* as it is inviting. There is an unusual degree of obscurity about the origin of the first printed books and the lives and works of the early printers. There are records and traditions which cannot be reconciled of at least three distinct inventions of printing. Its early history is entangled with a controversy about rival inven-

Lower case a to z, 14 $\frac{1}{4}$  ems

ABCDEFGHIJKLMNOPQRSTUVWXYZ  
1234567890

10 POINT NO. 54

THE INVENTION OF PRINTING has always been recognized by educated men as a subject of great importance: there is no mechanical art, nor are there any of the fine arts, about whose *early history* so many volumes have been written. The subject is as mysterious as it is inviting. There is an unusual degree of obscurity about the origin of the first printed books and the lives and works of the early printers. There are

Lower case a to z, 12 3-5 ems

ABCDEFGHIJKLMNOPQRSTUVWXYZ  
1234567890

5½ POINT NO. 53



THE INVENTION OF PRINTING has always been recognized by educated men as a subject of importance: there is no mechanical art, nor are there any of the fine arts, about whose history so many books have been written. The subject is no less mysterious than it is inviting. There is an unusual degree of obscurity about the origin of the first printed books and the lives and works of the early printers. There are records and traditions which cannot be reconciled of at least *three distinct inventions* of printing. Its early history is entangled with a controversy about rival inventors which has lasted for more than three centuries, and is not yet determined. In the management of this controversy, an intrinsically attractive subject has been made quite repulsive. The history of the invention of printing has been written to please public pride. German authors assert the claims of Gutenberg, and discredit traditions about Coster. Dutch authors must insist on the priority of Coster and charge Gutenberg with stealing the invention. Partisans on each side

Lower case a to z, 16¼ ems

ABCDEFGHIJKLMN OPQRSTUVWXYZ  
1234567890

6 POINT NO. 53

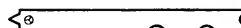

THE INVENTION OF PRINTING has always been recognized by educated men as a subject of importance: there is no mechanical art, nor are there any of the fine arts, about whose history so many books have been written. The subject is as mysterious as it is inviting. There is an unusual degree of obscurity about the origin of the first printed books and the lives and *works of the early printers*. There are records and traditions which cannot be reconciled of at least three distinct inventions of printing. Its early history is entangled with a controversy about rival inventors which has lasted for more than three centuries and is not yet fully determined. In the management of this controversy a subject very attractive has been made repulsive. The history of the invention of printing has been written to please public pride. German authors assert the claims of Gutenberg, and discredit traditions about Coster. Dutch authors must insist on the priority of Coster and charge

Lower case a to z, 15½ ems

ABCDEFGHIJKLMN OPQRSTUVWXYZ  
1234567890

7 POINT NO. 53

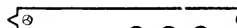

THE INVENTION OF PRINTING has always been recognized by educated persons as a subject of importance: there is no mechanical art, nor are there any of the fine arts, about whose history so many books have been written. The subject is as mysterious as it is inviting. There is an unusual degree of obscurity about the *origin of the first printed books* and the lives and works of the early printers. There are records and traditions which cannot be reconciled of at least three distinct inventions of printing. Its early history is entangled with a controversy about rival inventors which has lasted for more than three centuries, and is not yet fully determined. In the management of this controversy, a subject very attractive has been made repulsive. The history of the invention of printing

Lower case a to z, 15½ ems

ABCDEFGHIJKLMN OPQRSTUVWXYZ  
1234567890

8 POINT No. 53

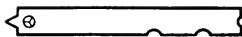

THE INVENTION OF PRINTING has been recognized by educated men always as a subject of importance: there is no mechanical art, nor are there any of the fine arts, about whose history so many books have been written. The subject is as mysterious as it is inviting. There is an unusual degree of obscurity about the origin of the first printed books and the lives and works of the early printers. There are *records and traditions* of at least three distinct inventions of printing which cannot be reconciled. Its early history is entangled with a controversy about rival inventors which has lasted for more than three centuries and is not yet fully determined. In the management of this controversy, a subject intrinsically attractive has been made repulsive. The history of the invention of printing has been written to please public pride. German authors assert the claims of Gutenberg and discredit traditions about Coster. Dutch authors must insist on the priority

Lower case a to z, 14 $\frac{3}{4}$  ems

ABCDEFGHIJKLMNOPQRSTUVWXYZ  
1234567890

9 POINT No 53



THE INVENTION OF PRINTING has been recognized by educated men as a subject of great importance: there is no mechanical art, nor are there any of the fine arts, about whose history so many books have been written. The subject is as mysterious as it is inviting. There is an unusual degree of obscurity about the origin of the first printed books and the lives and works of the early printers. There are *records and traditions* which cannot be reconciled of at least three distinct inventions of book printing. Its early history is entangled with a great controversy about rival inventors which has lasted more than three centuries, and is not yet fully determined. In the management of this controversy an intrinsically attractive subject has been made repulsive. The history of the invention of printing has been written to please public pride. All German authors assert the claims of Gutenberg and discredit traditions about Coster. Dutch

Lower case a to z, 13 ems

ABCDEFGHIJKLMNOPQRSTUVWXYZ  
1234567890

5 POINT No. 57



THE INVENTION OF PRINTING has always been recognized by educated men as a subject of importance: there is no mechanical art, nor are there any of the fine arts, about whose history so many books have been written. The subject is as mysterious as it is inviting. There is an unusual degree of obscurity about the origin of the *first printed books* and the lives and works of the early book printers. There are records and traditions which cannot be reconciled of at least three distinct inventions of printing. Its early history is entangled with a controversy about rival inventors which has lasted more than three centuries and is not yet fully determined. In the management of this controversy, a subject intrinsically attractive has been made repulsive. The history of the

Lower case a to z, 17 ems

ABCDEFGHIJKLMN OPQRSTUVWXYZ  
1234567890

5½ POINT No. 57

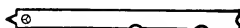

THE INVENTION OF PRINTING has always been recognized by educated men as a subject of importance: there is no mechanical art, nor are there any of the fine arts, about whose history so many books have been written. The subject is as mysterious as it is inviting. There is an unusual degree of obscurity about the origin of the *first printed books* and the lives and works of the early printers. There are records and traditions which cannot be reconciled of at least three distinct inventions of printing. Its early history is entangled with a controversy about rival inventors which has lasted for over three centuries, and is not yet fully determined. In the management of

Lower case a to z, 16 ems

ABCDEFGHIJKLMN OPQRSTUVWXYZ  
1234567890

6 POINT No. 57



THE INVENTION OF PRINTING has always been recognized by men of education as a subject of importance: there is no mechanical art, nor are there any of the fine arts, about whose history so many books have been written. The subject is as mysterious as it is inviting. There is an unusual *degree of obscurity* about the origin of the first printed books and the lives and works of the early printers. There are records and traditions which cannot be reconciled of at least three distinct inventions of printing. Its early history is entangled with a controversy

Lower case a to z, 15¼ ems

ABCDEFGHIJKLMN OPQRSTUVWXYZ  
1234567890

7 POINT No. 57

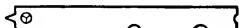

THE INVENTION OF PRINTING has always been recognized by educated men as a subject of importance: there is no mechanical art, nor are there any of the fine arts, about whose history so many books *have been written*. The subject is as mysterious as it is inviting. There is an unusual degree of obscurity about the origin of the first printed books and the lives and works of the early book printers. There are records and traditions which cannot be

Lower case a to z, 14¾ ems

ABCDEFGHIJKLMN OPQRSTUVWXYZ  
1234567890

8 POINT No. 57

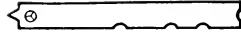

THE INVENTION OF PRINTING has always been recognized by educated men as a subject of importance: there is no mechanical art, nor are there any fine arts, about whose history so many books have been written. The subject is as mysterious as it is inviting. There is an unusual degree of obscurity about the *origin of the first printed books* and the lives and works of the early printers. There are records and traditions which cannot be reconciled of at least three distinct inventions of printing. Its early history is entangled

Lower case a to z, 14 ems

ABCDEFGHIJKLMN OPQRSTUVWXYZ  
1234567890

9 POINT No. 57



THE INVENTION OF PRINTING has been recognized by educated men always as a subject of importance: there is no mechanical art, nor are there any of the fine arts, about whose early history so many books have been written. *There is an unusual degree* of obscurity about the origin of the first printed books and the lives and works of the early printers. There are records and traditions which cannot be reconciled of at least three

Lower case a to z, 13½ ems

ABCDEFGHIJKLMN OPQRSTUVWXYZ  
1234567890

10 POINT No. 57



THE INVENTION OF PRINTING has always been recognized by educated men as a subject of great importance: there is no mechanical art, nor are there any of the fine arts, *about whose history* so many books have been published. There is an unusual degree of obscurity about the origin of the first printed books and the lives and works of the early printers. There are records and traditions which

Lower case a to z, 13¼ ems

ABCDEFGHIJKLMN OPQRSTUVWXYZ  
1234567890

AMERICAN TYPE FOUNDERS CO.

---

6 POINT NO. 60

THE INVENTION OF PRINTING has always been recognized by educated men as a subject of importance: there is no mechanical art, nor are there *any of the fine arts*, about whose early history so many books have been written. The subject is as mysterious as it is inviting. There is an unusual degree of obscurity about the origin of the first printed books and the lives and works of the early printers. There are records and traditions which cannot be reconciled of at least three distinct inventions of printing. Its early history is entangled with a controversy about

Lower case a to z, 15½ ems

ABCDEFGHIJKLMNOPQRSTUVWXYZ  
1234567890

7 POINT NO. 60

THE INVENTION OF PRINTING has always been recognized by educated men as a subject of importance: there is no mechanical art, nor are there *any of the fine arts*, about whose early history so many books have been written. The subject is as mysterious as it is inviting. There is an unusual degree of obscurity about the origin of the first printed books and the lives and works of the early printers. There are records and traditions which cannot be

Lower case a to z, 14½ ems

ABCDEFGHIJKLMNOPQRSTUVWXYZ  
1234567890

8 POINT NO. 60

THE INVENTION OF PRINTING has always been recognized by educated men as a subject of importance: there is no mechanical art, nor are there *any of the fine arts*, about whose early history so many books have been written. The subject is as mysterious as it is inviting. There is an unusual degree of obscurity about the origin of the first printed books and the lives and works of the early printers. There are records and

Lower case a to z, 13 ems

ABCDEFGHIJKLMNOPQRSTUVWXYZ  
1234567890

9 POINT NO. 60

THE INVENTION OF PRINTING has always been recognized by educated men as a subject of importance: there is no mechanical art, nor are there *any of the fine arts*, about whose early history so many books have been written. The subject is as mysterious as it is inviting. There is an unusual degree of obscurity about the origin of the first printed

Lower case a to z, 12½ ems

ABCDEFGHIJKLMNOPQRSTUVWXYZ  
1234567890



## 10 POINT No. 60

THE INVENTION OF PRINTING has always been recognized by educated men as a subject of importance: there is no mechanical art, nor are there *any of the fine arts*, about whose early history so many books have been written. The subject is as mysterious as it is inviting. There is an unusual degree of obscurity about the origin of the first printed books and the lives and works of the early printers. There are records

Lower case a to z, 12½ ems

ABCDEFGHIJKLMNOPQRSTUVWXYZ  
1234567890

## 11 POINT No. 60

THE INVENTION OF PRINTING has always been recognized by educated men as a subject of importance: there is no mechanical art, nor are there *any of the fine arts*, about whose early history so many books have been written. The subject is as mysterious as it is inviting. There is an unusual degree of obscurity about the origin of the first printed books and

Lower case a to z, 11½ ems

ABCDEFGHIJKLMNOPQRSTUVWXYZ  
1234567890

## 12 POINT No. 60

THE INVENTION OF PRINTING has always been recognized by educated men as a subject of importance: there is no mechanical art, nor are there *any of the fine arts*, about whose early history so many books have been written. The subject is as mysterious as it is inviting. There

Lower case a to z, 12¼ ems

ABCDEFGHIJKLMNOPQRSTUVWXYZ  
1234567890

**American Press Association Series No. 61**

6 POINT

THE INVENTION OF PRINTING has always been recognized by men of education as a subject of importance: there is no mechanical art, nor are there any of the fine arts, about whose early history so many books have been written. The subject is no less mysterious than it is inviting. There is an unusual *degree of obscurity* about the origin of the first printed books and the lives and works of the early printers. There are records and traditions which cannot be

Lower case a to z, 16 $\frac{1}{2}$  ems

ABCDEFGHIJKLMNOPQRSTUVWXYZ  
1234567890

7 POINT

THE INVENTION OF PRINTING has always been recognized by educated men as a subject of much importance: there is no mechanical art, nor are there any of the fine arts, about whose history so many books have been written. The subject is as mysterious as it is inviting. There is an unusual degree of obscurity about the *origin of the first* printed books and the

Lower case a to z, 15 $\frac{1}{2}$  ems

ABCDEFGHIJKLMNOPQRSTUVWXYZ  
1234567890

8 POINT

THE INVENTION OF PRINTING has always been recognized by educated men as a subject of importance: there is no mechanical art, nor are there any of the fine arts, about whose early history so many volumes have been written. The subject is as mysterious as it is inviting. There is an unusual degree of *obscurity about the origin* of the first

Lower case a to z, 14 $\frac{1}{2}$  ems

ABCDEFGHIJKLMNOPQRSTUVWXYZ  
1234567890

9 POINT

THE INVENTION OF PRINTING has been recognized by educated men as a subject of importance: there is no mechanical art, nor are there any of the fine arts, about whose early history so many volumes have been written. The *subject is as mysterious* as

Lower case a to z, 15 $\frac{1}{4}$  ems

ABCDEFGHIJKLMNOPQRSTUVWXYZ  
1234567890

## COPPER ALLOY TYPE

5½ POINT No. 66



THE INVENTION OF PRINTING has always been recognized by educated men as a subject of importance: there is no mechanical art, nor are there any of the fine arts, about whose history so many books have been written. The subject is no less mysterious than it is inviting. There is an unusual degree of obscurity about the origin of the first printed books and the lives and works of the early printers. There are *records and traditions* which cannot be reconciled of at least three distinct inventions of printing. Its history is entangled with a controversy about rival inventors which has lasted for more than three centuries and is not yet fully determined. In the management of this controversy, an intrinsically

Lower case a to z, 15 ems

ABCDEFGHIJKLMNOPQRSTUVWXYZ

1234567890

6 POINT No. 66

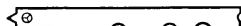

THE INVENTION OF PRINTING has always been recognized by educated men as a subject of importance: there is no mechanical art, nor are there any of the fine arts, about whose history so many books have been written. The subject is as mysterious as it is inviting. There is an unusual degree of obscurity about the origin of the *first printed books* and the lives and works of early printers. There are records and traditions which cannot be reconciled of at least three distinct inventions of printing. Its early history is entangled with a controversy about rival inventors which has

Lower case a to z, 15 ems

ABCDEFGHIJKLMNOPQRSTUVWXYZ

1234567890

7 POINT No. 66



THE INVENTION OF PRINTING has always been recognized by men of education as a subject of importance: there is no mechanical art nor are there any of the fine arts, about whose history so many books have been written. There is an *unusual degree* of obscurity about the origin of the first printed books and the lives and works of the early printers. There are records and traditions which cannot be reconciled of at least three distinct inventions of printing. Its early

Lower case a to z, 14¼ ems

ABCDEFGHIJKLMNOPQRSTUVWXYZ

1234567890

8 POINT No. 66



THE INVENTION OF PRINTING has always been recognized by educated men as a subject of importance: there is no mechanical art, nor are there any of the fine arts, about whose history *so many books* have been written. There is an unusual degree of obscurity about the origin of the first printed books and the lives and works of the early printers. There are records and traditions which cannot be reconciled

Lower case a to z, 14 ems

ABCDEFGHIJKLMNOPQRSTUVWXYZ

1234567890

8 POINT No. 64



THE INVENTION OF PRINTING has always been recognized by educated men as a subject of importance, and there is no mechanical art, nor are there any of the fine arts, about whose history so many books *have been written*. The subject is as mysterious as it is inviting. There is an unusual degree of obscurity about the origin of the first printed books and the lives and works of the early printers. There are records and traditions which cannot be reconciled of at least three distinct inventions of printing. Its early history is entangled with a controversy about rival inventors which has lasted for more than

Lower case a to z, 13½ ems

ABCDEFGHIJKLMNOPQRSTUVWXYZ  
1234567890

9 POINT No. 64

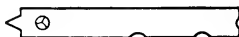

THE INVENTION OF PRINTING has always been recognized by educated men as a subject of importance: there is no mechanical art, nor are there any of the fine arts, about whose history so *many books have been written*. And the subject is as mysterious as it is inviting. There is an unusual degree of obscurity about the origin of the first printed books, and the lives and works of the early book printers. There are records and traditions which cannot be reconciled of at least three distinct inventions of book

Lower case a to z, 13 ems

ABCDEFGHIJKLMNOPQRSTUVWXYZ  
1234567890

10 POINT No. 64



THE INVENTION OF PRINTING has been recognized by educated men as a subject of importance: there is no mechanical art, nor are there any of the fine arts, about whose history *so many books* have been written. The subject is no less mysterious than it is inviting. There is an unusual degree of obscurity about the origin of the first printed books and the lives and works of the early printers. There are

Lower case a to z, 13 ems

ABCDEFGHIJKLMNOPQRSTUVWXYZ  
1234567890

11 POINT No. 64



THE INVENTION OF PRINTING has always been recognized by educated men as a subject of great importance: there is no mechanical art, nor are there any of the fine arts, about whose early history so *many books* have been written. The subject is as mysterious as it is inviting. There is an unusual degree of

Lower case a to z, 13 $\frac{3}{4}$  ems

ABCDEFGHIJKLMNOPQRSTUVWXYZ  
1234567890

12 POINT No. 64



THE INVENTION OF PRINTING has always been recognized by educated men as a subject of great importance: there is no mechanical art, nor are there any of the fine arts, *about whose history* so many books have been published. There is an

Lower case a to z, 13 $\frac{3}{4}$  ems

ABCDEFGHIJKLMNOPQRSTUVWXYZ  
1234567890

14 POINT No. 64



THE INVENTION OF PRINTING has always been recognized by educated men as a subject of *great importance*: there is no mechanical art, nor are there any of the fine arts, about whose history so many

ABCDEFGHIJKLMNOPQRSTUVWXYZ  
1234567890

5½ POINT No. 65

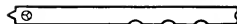

THE INVENTION OF PRINTING has always been recognized by educated men as a subject of importance: there is no mechanical art, nor are there any of the fine arts, about whose history so many books have been written. The subject is as mysterious as it is inviting. There is an unusual degree of obscurity about the origin of the first printed books and the lives and works of the early book printers. There are *records and traditions which cannot* be reconciled of at least three distinct inventions of printing. Its early history is entangled with a controversy about rival inventors which has lasted for more than three centuries, and is not yet fully determined. In the management of this great

Lower case a to z, 15¾ ems

ABCDEFGHIJKLMN OPQRSTUVWXYZ  
1234567890

6 POINT No. 65



THE INVENTION OF PRINTING has always been recognized by educated men as a subject of importance: there is no mechanical art, nor are there any of the fine arts, about whose history so many books have been written. The subject is as mysterious as it is inviting. There is an unusual degree of obscurity about the *origin of the first printed books* and the lives and works of the early printers. There are records and traditions which cannot be reconciled of at least three distinct inventions of printing. Its early history is entangled with a controversy about rival inventors which has lasted for

Lower case a to z, 15 ems

ABCDEFGHIJKLMN OPQRSTUVWXYZ  
1234567890

7 POINT No. 65



THE INVENTION OF PRINTING has always been recognized by men of education as a subject of importance: there is no mechanical art, nor are there any of the fine arts about whose history so many books have been written. The subject is as mysterious as it is inviting. There is an unusual degree of obscurity about the origin of the first printed books and the lives and works of the early printers. There are records and traditions which cannot be reconciled of no less than three distinct

Lower case a to z, 13⅔ ems

ABCDEFGHIJKLMN OPQRSTUVWXYZ  
1234567890

8 POINT No. 65



THE INVENTION OF PRINTING has always been recognized by educated men as a subject of great importance: there is no mechanical art, nor are there any of the fine arts, about whose history so *many books have been written*. The subject is as mysterious as it is inviting. There is an unusual degree of obscurity about the origin of the first printed books and the lives and works of the early printers. There are records and

Lower case a to z, 14 ems

ABCDEFGHIJKLMN OPQRSTUVWXYZ  
1234567890

9 POINT No. 65



THE INVENTION OF PRINTING has been recognized by men of education as a subject of great importance: there is no mechanical art, nor are there any of the fine arts, about whose early history so many books *have been written*. The subject is as mysterious as it is inviting. There is a degree of obscurity about the origin of the first printed books and the lives and works of the early book printers. There are records and traditions which cannot be reconciled of at least

Lower case a to z, 12¼ ems

ABCDEFGHIJKLMN OPQRSTUVWXYZ  
1234567890

10 POINT No. 65



THE INVENTION OF PRINTING has been recognized by educated men as a subject of importance: there is no mechanical art, nor are there any of the fine arts, about whose history so *many books* have been written. The subject is as mysterious as it is inviting. There is an unusual degree of obscurity about the origin of the first printed books and the lives and works of the early book printers. There are records and traditions which

Lower case a to z, 12¼ ems

ABCDEFGHIJKLMN OPQRSTUVWXYZ  
1234567890

11 POINT No. 65

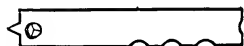

THE INVENTION OF PRINTING has always been recognized by educated men as a subject of great importance: there is no mechanical art, nor are there any of the *fine arts*, about whose history so many books have been written. The subject is as mysterious as it is inviting. There is an unusual degree of obscurity about the origin of the first

Lower case a to z, 12¼ ems

ABCDEFGHIJKLMN OPQRSTUVWXYZ  
1234567890

AMERICAN TYPE FOUNDERS CO.

5½ POINT No. 67



THE INVENTION OF PRINTING has always been recognized by educated men as a subject of importance: there is no mechanical art, nor are there any of the fine arts, about whose history so many books have been written. The subject is as mysterious as it is inviting. There is an unusual degree of obscurity about the origin of the first printed books and the *lives and works* of early printers. There are records and traditions which cannot be reconciled of at least three distinct inventions of printing. Its early history is entangled with a controversy about rival inventors which has lasted for more than three centuries, and is not yet fully determined. In the management of this controversy, an intrinsically attractive

Lower case a to z, 15½ ems

ABCDEFGHIJKLMNOPQRSTUVWXYZ

1234567890

6 POINT No. 67

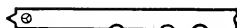

THE INVENTION OF PRINTING has always been recognized by educated men as a subject of much importance: there is no mechanical art, nor are there any of the fine arts, about whose history so many books have been written. The subject is no less mysterious than it is inviting. There is an unusual degree of obscurity *about the origin* of the first printed books and the *lives and works* of the early printers. There are records and traditions which cannot be reconciled of at least three distinct inventions of printing. Its early history is entangled with a controversy about rival

Lower case a to z, 15½ ems

ABCDEFGHIJKLMNOPQRSTUVWXYZ

1234567890

7 POINT No. 67



THE INVENTION OF PRINTING has always been recognized by educated men as a subject of importance: there is no mechanical art, nor are there any of the fine arts, about whose history so many books have been written. The subject is as mysterious as it is inviting. There is *an unusual degree* of obscurity about the origin of the first printed books and the *lives and works* of the early printers. There are records and traditions which cannot be

Lower case a to z, 14¾ ems

ABCDEFGHIJKLMNOPQRSTUVWXYZ

1234567890

8 POINT No. 67



THE INVENTION OF PRINTING has always been recognized by educated men as a subject of importance: there is no mechanical art, nor are there any of the fine arts, about whose history so many books *have been written*. The subject is as mysterious as it is inviting. There is an unusual degree of obscurity about the origin of the first printed books and the *lives and works* of the early printers. There are records and

Lower case a to z, 14 ems

ABCDEFGHIJKLMNOPQRSTUVWXYZ

1234567890



9 POINT NO. 67



THE INVENTION OF PRINTING has always been recognized by educated men as a subject of importance: there is no mechanical art, nor are there any of the fine arts, about whose history so many books have been written. The subject is as mysterious as it is inviting. There is an unusual degree of obscurity about the origin of the *first printed books* and the lives and works of the early printers. There are records and traditions which cannot be reconciled of at least three

Lower case a to z, 12½ ems

ABCDEFGHIJKLMNOPQRSTUVWXYZ  
1234567890

10 POINT NO. 67



THE INVENTION OF PRINTING has been recognized by people of education always as a subject of great importance: there is no mechanical art, nor are there any of the fine arts, *about whose history* so many books have been written. The subject is as mysterious as it is inviting. There is an unusual degree of obscurity about the origin of the first printed books as well as the lives and works of the early printers. There are

Lower case a to z, 12½ ems

ABCDEFGHIJKLMNOPQRSTUVWXYZ  
1234567890

11 POINT NO. 67



THE INVENTION OF PRINTING has been recognized by educated men as a subject of importance: there is no mechanical art, nor are there any of the fine arts, about whose history so many books have been written. There is an *unusual degree* of obscurity about the origin of the first printed books and the lives and works of the early printers. There are

Lower case a to z, 12 ems

ABCDEFGHIJKLMNOPQRSTUVWXYZ  
1234567890

12 POINT No. 67

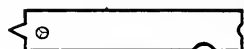

THE INVENTION OF PRINTING has always been recognized by educated men as a subject of importance: there is no mechanical art, nor are there any of the fine arts, about whose early history *so many publications* have been produced. There is an unusual degree of obscurity about the origin of the first printed books and the lives and works of the early printers. There are records and traditions which cannot be reconciled of at least three

Lower case a to z, 12½ ems

ABCDEFGHIJKLMNOPQRSTUVWXYZ  
1234567890

18 POINT No. 67



THE INVENTION OF PRINTING has always been recognized by educated persons as a subject of much *importance*: there is no mechanical art, nor are there any of the fine arts, about whose history so many books have been written. The subject is no less

ABCDEFGHIJKLMNOPQRSTUVWXYZ  
1234567890

COPPER ALLOY TYPE

6 POINT No. 68



THE INVENTION OF PRINTING has always been recognized by men of education as a subject of importance; there is no mechanical art, nor are there any of the fine arts, about whose history so many books have been written. The subject is no less mysterious than it is inviting. There is an unusual degree of obscurity about the origin of the first printed books and the lives and works of the early printers. There are records and traditions which cannot be reconciled of at least *three distinct inventions* of printing. Its early history is entangled with a controversy about rival inventors which has lasted for more than three centuries, and is not yet fully determined. In the management of this controversy an attractive subject has been made repulsive. The history of the invention of printing has been written to please public pride. German authors

Lower case a to z, 17 ems

ABCDEFGHIJKLMNOPQRSTUVWXYZ

1234567890

7 POINT No. 63

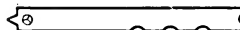

THE INVENTION OF PRINTING has always been recognized by educated men as a subject of much importance; there is no mechanical art, nor are there any of the fine arts, about whose history so many books have been written. The subject is as mysterious as it is inviting. There is an unusual degree of obscurity about the origin of the first printed books and the lives and works of *the early printers*. There are records and traditions which cannot be reconciled of at least three distinct inventions of printing. Its early history is entangled with a controversy about rival inventors which has lasted for more than three centuries, and is not yet fully determined. In the management of this controversy, an intrinsically attractive

Lower case a to z, 15½ ems

ABCDEFGHIJKLMNOPQRSTUVWXYZ

1234567890

8 POINT No. 68

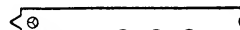

THE INVENTION OF PRINTING has always been recognized by educated men as a subject of importance; there is no mechanical art, nor are there any of the fine arts, about whose history so many books have been written. The subject is as mysterious as it is inviting. There is an unusual degree of obscurity about the origin of the first printed books as well as the *lives and works* of the early printers. There are records and traditions which cannot be reconciled of at least three distinct inventions of book printing. Its history is entangled with a controversy

Lower case a to z, 14¼ ems

ABCDEFGHIJKLMNOPQRSTUVWXYZ

1234567890

POSTER ROMAN SERIES

18 POINT NO. 120

22A 14A 124a \$12 48

INVENTION OF PRINTING  
HAS EVER BEEN RECOGNIZED BY  
Educated Men as a Godsend for  
Transmitting Mature Thought  
to the Minds of the Uncultured

20 POINT NO. 120

12A 8A 78a \$12 48

PRINTING SHOWED  
LEARNED MEN AVENUES  
Whereby Eminent Ideas  
Could be Transmitted to  
Ignorant Minds for  $42\frac{3}{4}$

24 POINT NO. 120

8A 5A 42a \$12 00

FRAME HOUSE  
LOCATED IN FINEST  
Suburban District  
For Sale Cheap  $2\frac{1}{2}$

POSTER ROMAN SERIES

—12—

30 POINT No. 120

6A 4A 27a \$12 00

EDUCATED  
MEN there are

48 POINT No. 120

6A 4A 34a \$23 00

POSTERS  
Need FINE

60 POINT No. 4

4A 4a \$8 95

PINED  
Artisan

POSTER ROMAN No. 123

—12—

★12 POINT

ITALIC 12A 24a \$2 65

12A 24a \$2 60

THE PRINTING INVENTIONS  
HAVE EVER BEEN RECOGNIZED BY  
educated men a subject of great  
importance; there is no greater  
art, nor are there any of the fine  
arts about *whose early history* so  
many books have been written.  
The subject is as mysterious as  
it is inviting. There is always a  
degree of obscurity about the  
origin of the first printed books  
and the lives and works of the

★18 POINT

ITALIC 12A 24a \$3 90

12A 24a \$4 55

RECORDED PRINTING  
EDUCATED THE POPULACE  
In the great mechanical  
arts, also in the fine arts  
about *whose real history* so  
many books have been  
written. The subject is  
mysterious and inviting.  
An unusual degree 233

TWENTY-FIVE POUNDS AND MULTIPLES AT ROMAN PRICES, COMPLETE WITH FIGURES, FRACTIONS  
AND SPACES AND QUADS.

POSTER ROMAN No. 123

12

★24 POINT

ITALIC 10A 20a \$4 55

10A 20a \$4 85

THE INVENTION OF  
PRINTING HAS BEEN  
recognized by men of  
education as a great  
Subject: *there* is not  
a mechanical art, nor  
are there any of 24½

★30 POINT

ITALIC 6A 12a \$4 55

6A 12a \$5 25

PRINTING AS  
AN INVENTION IS  
*recognized* by all  
educated people  
as a subject 56¼

CENTURY ROMAN

8 POINT

THE INVENTION OF PRINTING has always been recognized by educated men as a subject of importance: there is no mechanical art, nor are there any of the fine arts, about whose early history so many books have been written. The subject is as mysterious as it is inviting. There is an unusual degree of *obscurity about* the origin of the first printed books and the lives and works of early printers. There are records and traditions which cannot be reconciled of at least three distinct inventions of printing. Its early history is entangled with a controversy about rival inventors which has lasted for

Lower case a to z, 12 ems

ABCDEFGHIJKLMNOPQRSTUVWXYZ  
1234567890

9 POINT

THE INVENTION OF PRINTING has always been recognized by educated men as a subject of importance: there is no mechanical art, nor are there any of the fine arts, about whose early history so many books have been written. The subject is as mysterious as it is inviting. There is an unusual degree of *obscurity about* the origin of the first printed books and the lives and works of the early printers. There are records and traditions which cannot be reconciled of at

Lower case a to z, 12¼ ems

ABCDEFGHIJKLMNOPQRSTUVWXYZ  
1234567890

10 POINT

THE INVENTION OF PRINTING has always been recognized by educated men as a subject of importance: there is no mechanical art, nor are there any of the fine arts, about whose *early history* so many books have been written. The subject is as mysterious as it is inviting. There is an unusual degree of *obscurity about* the origin of the first printed books and the lives and works of the early printers. There are records and

Lower case a to z, 12 ems

ABCDEFGHIJKLMNOPQRSTUVWXYZ  
1234567890



## COPPER ALLOY TYPE

### 5½ POINT OLD STYLE NO. 73

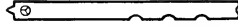

THE INVENTION OF PRINTING has always been recognized by educated men as a subject of importance; there is no mechanical art, nor are there any of the fine arts, about whose history so many books have been written. The subject is as mysterious as it is inviting. There is an unusual degree of obscurity about the origin of the first printed books and the lives and works of the early book printers. There are records and traditions of at least three distinct inventions of book printing. Its *early history* is entangled with a controversy about rival inventors which has lasted more than three centuries and is not yet fully determined. In the management of this controversy, a subject intrinsically attractive has been made repulsive. The history of the invention of printing has been written to please national pride. German authors assert the prior claims of Gutenberg and discredit traditions about Coster. Dutch authors must insist upon the priority of Coster, and charge Gutenberg with stealing the invention. Partisans on each side say that their

Lower case a to z, 16½ ems

ABCDEFGHIJKLMNOPQRSTUVWXYZ  
1234567890

### 6 POINT OLD STYLE NO. 73



THE INVENTION OF PRINTING has always been recognized by educated men as a subject of importance; there is no mechanical art, nor are there any of the fine arts, about whose history so many books have been written. The subject is now as mysterious as it is inviting. There is an unusual degree of obscurity about the origin of the first printed books and the lives and works of the early book printers. There are *records and traditions* which cannot be reconciled of at least three distinct inventions of printing. Its early history is entangled with a controversy about rival inventors which has lasted for more than three centuries, and is not yet fully determined. In the management of this controversy, a subject intrinsically attractive has been made repulsive. The history of the invention of printing was written to please national pride. German authors assert the claims of Gutenberg and discredit traditions about Coster. Dutch authors

Lower case a to z, 16½ ems

ABCDEFGHIJKLMNOPQRSTUVWXYZ  
1234567890

### 7 POINT OLD STYLE NO. 73



THE INVENTION OF PRINTING has always been recognized by educated men as a subject of importance; there is no mechanical art, nor are there any of the fine arts, about whose history so many books have been written. The subject is as mysterious as it is inviting. There is an unusual *degree of obscurity* about the origin of the first printed books and the lives and works of the early book printers. There are records and traditions which cannot be reconciled of at least three distinct inventions of printing. Its early history is entangled with a controversy about rival inventors which has lasted for more than three centuries, and is not yet fully determined. In the management of this controversy, a subject intrinsically attractive has been made repulsive. The history of

Lower case a to z, 15⅔ ems

ABCDEFGHIJKLMNOPQRSTUVWXYZ  
1234567890

AMERICAN TYPE FOUNDERS CO.

5½ POINT OLD STYLE NO. 80

THE INVENTION OF PRINTING has always been recognized by educated men as a subject of importance: there is no mechanical art, nor are there *any of the fine arts*, about whose early history so many books have been written. The subject is as mysterious as it is inviting. There is an unusual degree of obscurity about the origin of the first printed books and the lives and works of the early printers. There are records and traditions which cannot be reconciled of at least three distinct inventions of printing. Its early history is entangled with a controversy about rival inventors which has lasted for more than three centuries, and is not yet fully determined. In the management of this controversy, a subject intrinsically attractive has been made repulsive. The history of the invention of printing has been written to please national pride. German authors assert the claims of Gutenberg and discredit traditions about Coster. Dutch authors insist on the priority of Coster and charge Gutenberg with stealing the invention. Partisans on each side say that their opponents have perverted the records and suppressed

Lower case a to z, 15 ems

ABCDEFGHIJKLMN OPQRSTUVWXYZ

1234567890

6 POINT OLD STYLE NO. 83



THE INVENTION OF PRINTING has always been recognized by educated men as a subject of much importance; there is no mechanical art, nor are there any of the fine arts, about whose history so many books have been written. The subject is no less mysterious than it is inviting. There is an unusual degree of obscurity about the origin of the first printed books and the lives and works of the early printers. There are records and traditions which *cannot be reconciled* of at least three distinct inventions of printing. Its early history is entangled with a controversy about rival inventors which has lasted for more than three centuries, and is not yet fully determined. In the management of this controversy an intrinsically attractive subject has been made repulsive. The history of the invention of printing has been written to please national pride. German authors assert the claims of Gutenberg, and discredit the traditions concerning Coster. Dutch authors must insist on the priority of Coster, and charge

Lower case a to z, 15¼ ems

ABCDEFGHIJKLMN OPQRSTUVWXYZ

1234567890

7 POINT OLD STYLE NO. 83



THE INVENTION OF PRINTING has always been recognized by educated men as a subject of importance; there is no mechanical art, nor are there any of the fine arts, about whose history so many books have been written. There is an unusual degree of obscurity about the origin of the first printed books and the lives and works of the early printers. There are records and traditions which cannot be reconciled of at least *three distinct inventions* of printing. Its early history is entangled with a controversy about rival inventors which has lasted for more than three centuries, and is not yet fully determined. In the management of this controversy, an intrinsically attractive subject has been made repulsive. The history of printing has been written to gratify national pride. German authors assert

Lower case a to z, 14 ems

ABCDEFGHIJKLMN OPQRSTUVWXYZ

1234567890

COPPER ALLOY TYPE

8 POINT OLD STYLE No. 83

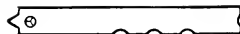

THE INVENTION OF PRINTING has been recognized by educated men as a subject of great importance; there is no mechanical art, nor are there any of the fine arts, about whose history so many books have been written. The subject is as mysterious as it is inviting. There is an unusual degree of obscurity about the origin of the *first printed books* and the lives and works of the early printers. There are records and traditions which cannot be reconciled of at least three distinct inventions of printing. Its early history is entangled

Lower case a to z, 14 ems

ABCDEFGHIJKLMNOPQRSTUVWXYZ

1234567890

9 POINT OLD STYLE No. 83



THE INVENTION OF PRINTING has been recognized by educated men as a subject of importance; there is no mechanical art, nor are there any of the fine arts, about whose history so many books have been written. The subject is as mysterious as it is inviting. There is an unusual degree of obscurity *about the origin* of the first printed books as well as the lives and works of the early printers. There are records and traditions which cannot

Lower case a to z, 13¼ ems

ABCDEFGHIJKLMNOPQRSTUVWXYZ

1234567890

10 POINT OLD STYLE No. 83

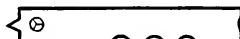

THE INVENTION OF PRINTING has always been recognized by educated men as a subject of great importance; there is no mechanical art, nor are there any of the fine arts, about whose history so many books *have been written*. The subject is as mysterious as it is inviting. There is an unusual degree of obscurity about the origin of the first printed books and the lives and works of the early

Lower case a to z, 13½ ems

ABCDEFGHIJKLMNOPQRSTUVWXYZ

1234567890

11 POINT OLD STYLE No. 83



THE INVENTION OF PRINTING has always been recognized by men of education as an important subject; there is no mechanical art, nor are there any of the fine arts, about whose history so many books have been written. The subject *is as mysterious* as it is inviting. There is an unusual degree of obscurity about the origin of the first printed books and the lives and works of the early printers. There are records and traditions which cannot be reconciled of at least three

Lower case a to z, 13¾ ems

ABCDEFGHIJKLMN OPQRSTUVWXYZ

1234567890

12 POINT OLD STYLE No. 83



THE INVENTION OF PRINTING has always been recognized by educated men as a subject of importance; there is no mechanical art, nor are there any of the fine arts, about whose history so many books *have been written*. There is an unusual degree of obscurity about the origin of the first printed books as well as the lives and works of the early book printers. There are records and traditions which cannot be reconciled of at least three distinct inventions of

Lower case a to z, 14 ems

ABCDEFGHIJKLMN OPQRST

1234567890

---

**OLD STYLE No. 83**

---

—12—

18 POINT

ITALIC 10A 20a \$3 10

8A \$0 55

10A 20a \$2 95

THE INVENTION OF PRINTING has always been recognized by men of education as a subject of great importance: there is no mechanical art, nor are there any of the fine arts, *about whose* history so many books have been written. The subject is mysterious 486  $\frac{1}{2}$

22 POINT

ITALIC 8A 16a \$3 80

6A \$0 75

8A 16a \$3 50

INVENTION OF PRINTING has been recognized by all men of *education* as a subject of importance: there is no mechanical art, nor are there any of the fine arts, about whose early history many 35  $\frac{3}{4}$

OLD STYLE No. 83

24 POINT

ITALIC 8A 16a \$4 25

6A \$0 95

8A 16a \$4 75

PRINTING INVENTION  
has been recognized  
by men of education  
as a *subject* of great  
importance: there is  
no mechanical 56 $\frac{1}{4}$

30 POINT

ITALIC 5A 10a \$5 00

4A \$1 00

6A 12a \$5 60

THE INVENTION  
of printing books  
been recognized  
by *educated* men  
as a great subject  
interesting 48 $\frac{1}{2}$

OLD STYLE No. 83

—12—

42 POINT

ITALIC 3A 6a \$6 00

3A 6a \$6 05

HISTORY  
Controversy  
brave *roman*

60 POINT

3A 6a \$10 25

Roamers  
near here  
when the

AMERICAN TYPE FOUNDERS CO.

6 POINT OLD STYLE No. 84



THE INVENTION OF PRINTING has always been recognized by educated men as a subject of great importance ; there is no mechanical art, nor are there any of the fine arts, about whose history so many books have been written. The subject is as mysterious as it is inviting. There is an unusual degree of obscurity about the origin of the first printed books and the lives and works of the early printers. There are records and traditions which cannot be reconciled of at least *three distinct inventions* of printing. Its early history is entangled with a controversy about rival inventors which has lasted more than three centuries, and is not yet fully determined. In the management of this controversy, a subject intrinsically attractive has been made repulsive. The history of the invention of printing has been written to please national pride. German authors assert the claims of Gutenberg and discredit traditions about Coster. Dutch authors must insist upon the

Lower case a to z, 15 ems

ABCDEFGHIJKLMNOPQRSTUVWXYZ

1234567890

7 POINT OLD STYLE No. 84



THE INVENTION OF PRINTING has always been recognized by educated men as a subject of importance ; there is no mechanical art, nor are there any of the fine arts, about whose history so many books have been written. The subject is really as mysterious as it is inviting. There is an unusual degree of obscurity about the origin of the first printed books and the lives and works of the early book printers. There are *records and traditions* which cannot be settled of at least three distinct inventions of printing. Its early history is entangled with a controversy about rival inventors which has lasted for more than three centuries, and is not yet fully determined. In the management of this controversy, a subject intrinsically attractive has

Lower case a to z, 14¼ ems

ABCDEFGHIJKLMNOPQRSTUVWXYZ

1234567890

8 POINT OLD STYLE No. 84

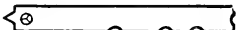

THE INVENTION OF PRINTING has been recognized by educated men as a subject of great importance ; there is no mechanical art, nor are there any of the fine arts, about whose history so many books have been written. The subject is as mysterious as it is inviting. There is an unusual degree of obscurity about the origin of the *first printed books* and the lives and works of the early printers. There are records and traditions which cannot be reconciled of at least three distinct inventions of printing. Its history is entangled with a controversy about rival inventors which has lasted for more than three centuries, and is not as yet fully determined

Lower case a to z, 14 ems

ABCDEFGHIJKLMNOPQRSTUVWXYZ

1234567890



COPPER ALLOY TYPE

10 POINT OLD STYLE NO. 84



THE INVENTION OF PRINTING has always been recognized by men of education as a subject of great importance; there is no mechanical art, nor are there any of the fine arts, *about whose early history* so many books have been written. The subject is as mysterious as it is inviting. There is an unusual degree of obscurity regarding the origin of the first

Lower case a to z, 13 ems

ABCDEFGHIJKLMNOPQRSTUVWXYZ

1234567890

11 POINT OLD STYLE NO. 84



THE INVENTION OF PRINTING has always been recognized by educated men as a subject of great importance; there is no mechanical art, nor are there any of the fine arts, *about whose history* so many books have been written. The subject is as mysterious as it is inviting. There is an unusual degree of obscurity about the origin of the first

Lower case a to z, 12½ ems

ABCDEFGHIJKLMNOPQRSTUVWXYZ

1234567890

12 POINT OLD STYLE NO. 84



THE INVENTION OF PRINTING has always been recognized by educated men as a subject of great importance; there is no mechanical art, nor are there any of the fine arts, *about whose early history so many books* have been published. There is an unusual degree of

Lower case a to z, 12½ ems

ABCDEFGHIJKLMNOPQRSTUVWXYZ

1234567890

**CUSHING SERIES.**

6 POINT

THE INVENTION OF PRINTING has always been recognized by educated men as a subject of importance: there is no mechanical art, nor are there any of the fine arts, about whose early history so many books have been written. The subject is as mysterious as it is inviting. There is an unusual degree of obscurity *about the origin* of the first printed books and the lives and works of the early printers. There are records and traditions which cannot be reconciled, of at

Lower case a to z, 13 $\frac{7}{8}$  ems

ABCDEFGHIJKLMNOPQRSTUVWXYZ  
1234567890

8 POINT

THE INVENTION OF PRINTING has always been recognized by educated men as a subject of importance: there is no mechanical art, nor are there any of the fine arts, *about whose early* history so many books have been written. The subject is as mysterious as it is inviting. There is an unusual degree of obscurity about

Lower case a to z, 12 $\frac{7}{8}$  ems

ABCDEFGHIJKLMNOPQRSTUVWXYZ  
1234567890

10 POINT

THE INVENTION OF PRINTING has always been recognized by educated men as a subject of importance: there is no mechanical art, nor are there any of the fine arts, about *whose early history* so many books have been written. The subject is as mysterious as it is inviting.

Lower case a to z, 11 $\frac{1}{4}$  ems

ABCDEFGHIJKLMNOPQRSTUVWXYZ  
1234567890

12 POINT

THE PRINTING INVENTION has always been recognized by educated men as a subject of importance: there is no mechanical art, nor are there *any of the fine arts*, about whose

Lower case a to z, 12 ems

ABCDEFGHIJKLMNOPQRSTUVWXYZ  
1234567890

FOR JOB FONTS, SEE PAGE 532

**CAXTON OLD STYLE**

12

6 POINT

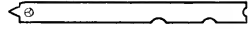

THE INVENTION OF PRINTING has always been recognized by educated men as a subject of great importance; there is no mechanical art, nor are there any of the fine arts about whose history so many books have been written. The subject is as mysterious as it is inviting. There is *an unusual degree* of obscurity about the origin of the first printed books and the lives and works of the early printers. There are records and

Lower case a to z, 18¾ ems

ABCDEFGHIJKLMN O P Q R S T U V W X Y Z  
1234567890

8 POINT



THE INVENTION OF PRINTING has always been recognized by educated persons as a subject of vast importance; there is no mechanical art, nor are there any of *the fine arts* about whose history so many books have been written. There is an unusual degree of obscurity about the origin of the first printed

Lower case a to z, 16½ ems

ABCDEFGHIJKLMN O P Q R S T U V W  
1234567890

10 POINT



THE INVENTION OF PRINTING has always been recognized by educated men as a subject of importance; there is no mechanical art, nor are there any of *the fine arts* about whose history

Lower case a to z, 15½ ems

ABCDEFGHIJKLMN O P Q R S T U V W  
1234567890

12 POINT

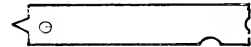

THE INVENTION OF PRINTING has been recognized by educated men as a subject of importance; *there* is no mechanical

Lower case a to z, 14½ ems

ABCDEFGHIJKLMN O P Q R S T U V  
1234567890

RONALDSON SERIES

6 POINT OLD STYLE NO. 72

THE INVENTION OF PRINTING has always been recognized by educated men as a subject of importance : there is no mechanical art, nor are there any of the fine arts, about whose early history so many books have been written. The subject is as mysterious as it is inviting. There is an unusual *degree of obscurity* about the origin of the first printed books and the lives and works of the early printers. There are records and traditions which cannot be reconciled of at least three distinct inventions of printing. Its early history is entangled with a controversy about rival inventors which has lasted for more than three centuries, and is not yet fully determined. In the management of this controversy, a subject intrinsically attractive has been made repulsive. The history of the invention of printing has been written to

Lower case a to z, 15½ ems

ABCDEFGHIJKLMNPOQRSTUVWXYZ

1234567890

7 POINT OLD STYLE NO. 72

THE INVENTION OF PRINTING has always been recognized by educated men as a subject of importance : there is no mechanical art, nor are there any of the fine arts, about whose early history so many volumes have been written. The subject is as mysterious as it is inviting. There is an *unusual degree* of obscurity about the origin of the first printed books and the lives and works of the early printers. There are records and traditions which cannot be reconciled of at least three distinct inventions of printing. Its early history is entangled with a controversy about rival inventors which has lasted for more than three centuries, and is not yet fully determined. In the management of

Lower case a to z, 14¾ ems

ABCDEFGHIJKLMNPOQRSTUVWXYZ

1234567890

8 POINT OLD STYLE NO. 72

THE INVENTION OF PRINTING has always been recognized by educated men as a subject of importance : there is no mechanical art, nor are there any of the fine arts, about whose early history so *many volumes* have been written. The subject is as mysterious as it is inviting. There is an unusual degree of obscurity about the origin of the first printed books and the lives and works of the early printers. There are records and traditions which cannot be reconciled of at least three distinct inventions of printing. Its early history is entangled with a controversy about rival inventors which has

Lower case a to z, 14 ems

ABCDEFGHIJKLMNPOQRSTUVWXYZ

1234567890

COPPER ALLOY TYPE

9 POINT OLD STYLE NO. 72

THE INVENTION OF PRINTING has always been recognized by educated men as a subject of importance: there is no mechanical art, nor are there any of the fine arts, about whose early history so many volumes have been written. The subject is as mysterious as it is inviting. There is an unusual degree of *obscurity* about the origin of the first printed books and the lives and works of the early printers. There are records and traditions which cannot be reconciled of at least three distinct inventions

Lower case a to z, 13½ ems

ABCDEFGHIJKLMNOPQRSTUVWXYZ

1234567890

10 POINT OLD STYLE NO. 72

THE INVENTION OF PRINTING has always been recognized by educated men as a subject of importance: there is no mechanical art, nor are there any of the fine arts, about whose early history so many books have been written. There is an unusual degree of obscurity about the origin of the first printed books and the lives and works of the early printers. There are records and *traditions* which cannot be

Lower case a to z, 13 ems

ABCDEFGHIJKLMNOPQRSTUVWXYZ

1234567890

11 POINT OLD STYLE NO. 72

THE INVENTION OF PRINTING has always been recognized by educated men as a subject of very great importance: there is no mechanical art, nor are there any of the fine arts, about whose early history so many volumes have been written. The subject is as *mysterious* as it is inviting. There is an unusual degree of obscurity about the origin

Lower case a to z, 12½ ems

ABCDEFGHIJKLMNOPQRSTUVWXYZ

1234567890

12 POINT OLD STYLE NO. 72

THE INVENTION OF PRINTING has always been recognized by educated men as a subject of importance: there is no mechanical art, nor are there any of the fine arts, about whose early history so many volumes have been written. The subject is as mysterious as it is inviting. There is an *unusual* degree of obscurity about the origin of the first printed books and the lives and works of the early printers. There are records and traditions which cannot be reconciled of at least three

Lower case a to z, 12½ ems

ABCDEFGHIJKLMN O P Q R S T U V W X Y  
 I 2 3 4 5 6 7 8 9 0

15 POINT OLD STYLE NO. 72

12A 6A 40a \$4 55

THE INVENTION of printing has been recognized by educated men as a subject of importance: there is no mechanical art, nor are there any of the fine arts, about whose early history so many books have been written. The subject is as mysterious as it is inviting. There is an unusual degree of obscurity about

ABCDEFGHIJKLMN O P Q R S T U  
 I 2 3 4 5 6 7 8 9 0

**Ronaldson Old Style No. 72**

48 POINT

5A 8a \$8 00

Mining TIN

36 POINT

6A 12a \$7 00

HARD Lumber

30 POINT

8A 16a \$5 85

Humorous JOKES

24 POINT

10A 20a \$4 70

Discovered in Australia  
RARE PRINTS

18 POINT

14A 30a \$4 30

Twenty-Four Genuine Rubies  
FAMOUS STONES

1234567890

RONALDSON CONDENSED

48 POINT

5A 8a \$5 90

Modern HOUSE

36 POINT

7A 12a \$5 25

RECENT Explosions

30 POINT

8A 14a \$4 15

Entertainment CLOSED

24 POINT

10A 18a \$3 60

Soldiers CROSSING Bayonets

18 POINT

14A 28a \$3 15

MINUTES of Geographical SOCIETY

12 POINT

22A 45a \$2 70

Journeying to Fairyland  
YOUNG LOVERS

8 POINT

30A 60a \$2 50

Theories Relentlessly Exploded  
SCIENTIFIC STUDIES

1234567890

10 POINT

26A 52a \$2 55

Ghost Story and Scarecrow  
TERRIFIED YOUTHS

6 POINT

36A 70a \$2 50

Trustworthy Dealings with the World  
EXCELLENT CHARACTER

1234567890



RONALDSON EXTENDED

48 POINT

4A 6a \$8 45

Red SIX

36 POINT

5A 8a \$6 55

TEN Lines

30 POINT

6A 10a \$5 40

Quaint SIGN

24 POINT

8A 12a \$4 65

FAWN Hunters

18 POINT

10A 16a \$4 00

Charming MAIDEN

12 POINT

18A 28a \$3 50

Large Trains  
LOADED

10 POINT

20A 30a \$3 00

Houses Painted  
RENEWED

8 POINT

22A 32a \$2 70

Railroad Company  
ORGANIZING

1234567890

6 POINT

25A 40a \$2 45

Popular Historic Event  
NOTED LECTURE

1234567890

RONALDSON CLARENDON

48 POINT

5A 8a \$8 35

Eight MEN

36 POINT

6A 10a \$7 00

BAND Concert

30 POINT

8A 16a \$6 05

Masculine FACES

24 POINT

10A 20a \$5 00

OBLONG Instrument

18 POINT

14A 28a \$4 65

Constitutional MEASURES

12 POINT

22A 45a \$3 95

Popular Teachers  
LECTURES

10 POINT

25A 50a \$3 55

Humorous Sketches  
DRAWINGS

8 POINT

30A 60a \$3 45

Electric Light Company  
INCANDESCENT

1234567890

6 POINT

36A 70a \$3 35

Medical Students Examined  
HOSPITAL SERVICE

1234567890

RONALDSON TITLE SLOPE

36 POINT

5A 8a \$6 00

*Grand* **RIDE**

30 POINT

6A 10a \$5 25

**CHILD** *Ranger*

24 POINT

8A 14a \$4 50

*Electrified* **STRAP**

18 POINT

12A 22a \$4 15

**THOROUGH** *Paralyzers*

12 POINT

20A 40a \$3 55

*Burglar Alarm for* **TURKEY COOP**

10 POINT

22A 45a \$3 35

**SUPERB SUMMER** *Landscape Scenery*

8 POINT

25A 50a \$3 15

*Warranted to Inflict Exquisite Torture Instantly*  
**CRIMINAL ELECTROCUTORS**

6 POINT

30A 60a \$3 00

*Announce That Their Electrical Machinery is Now Ready*  
**VOLTMETRE, DYNAMO AND COMPANY**

1 2 3 4 5 6 7 8 9 0

RONALDSON GOTHIC

48 POINT

5A 7a \$7 15

Silver MOON

36 POINT

6A 9a \$5 80

FALSE Reports

30 POINT

8A 12a \$4 95

HOMES Destroyed

24 POINT

10A 15a \$3 70

TUMBLING Foundations

18 POINT

12A 18a \$3 15

Mould Statue  
ARTISTS

14 POINT

18A 28a \$3 15

Strong Animals  
FEROCIOUS

12 POINT

22A 34a \$3 10

Shared by Adults  
ENJOYMENT

10 POINT

28A 45a \$3 10

Courteous Diplomats  
YOUNG MAIDEN

8 POINT

38A 55a \$3 10

Wriggling Down Chimneys  
OLD KRISS KRINGLE

6 POINT

40A 60a \$3 10

Endeavor to Please Children  
PLEASANT PURSUITS

1234567890

1234567890

**CASLON SERIES**

4

6 POINT OLD STYLE NO. 71

25A 15A 170a \$6 95

THE INVENTION OF PRINTING has always been recognized by educated men as a subject of importance: there is no mechanical art, nor are there any of the fine arts, about whose early history so many volumes have been written. The subject is as mysterious as it is inviting. There is an unusual degree of obscurity about the origin of the first printed books and the lives and works of the early printers. There are records and traditions which cannot be reconciled of at least three distinct inventions of printing. Its *early history* is entangled with a controversy about rival inventors which has lasted for more than three centuries, and is not yet fully determined. In the management of this controversy, a subject intrinsically attractive has been made repulsive. The history of the invention of printing has been written to please national pride. German authors assert the claims of Gutenberg

Lower case a to z, 13½ ems

ABCDEFGHIJKLMNQRSTU VWXYZ

1234567890

8 POINT OLD STYLE NO. 71

20A 12A 120a \$5 40

THE INVENTION OF PRINTING has always been recognized by educated men as a subject of great importance: there is no mechanical art, nor are there any of the fine arts, about whose early history so many volumes have been written. The subject is as *mysterious* as it is inviting. There is an unusual degree of obscurity about the origin of the first printed books and the lives and works of the early printers. There are records and traditions which cannot be reconciled of at least three distinct inventions of printing. Its early history is entangled with a controversy about rival inventors which has lasted for more than three centuries, and is not yet fully determined. In the management of this controversy, a subject intrinsically attractive has

Lower case a to z, 11½ ems

ABCDEFGHIJKLMNQRSTU VWXYZ

1234567890

9 POINT OLD STYLE NO. 71

THE INVENTION OF PRINTING has always been recognized by educated men as a subject of great importance: there is no mechanical art, nor are there any of the fine arts, about whose early history so *many volumes* have been written. The subject is as mysterious as it is inviting. There is an unusual degree of obscurity about the origin of the first printed books and the lives and works of the early printers. There are records and traditions which cannot be reconciled of at least three distinct inventions of printing. Its early history is entangled with a

Lower case a to z, 11 2-5 ems

ABCDEFGHIJKLMNQRSTU VWXYZ

1234567890

10 POINT OLD STYLE NO. 71

15A 8A 75a \$4 45

THE INVENTION OF PRINTING has always been recognized by educated men as a subject of great importance: there is no mechanical art, nor are there any of the fine arts, about whose *early history* so many books have been written. The subject is as mysterious as it is inviting. There is an unusual degree of obscurity about the origin of the first printed books and the lives and works of the

Lower case a to z, 11¼ ems

ABCDEFGHIJKLMNOPQRSTUVWXYZ

1234567890

11 POINT OLD STYLE NO. 71

THE INVENTION OF PRINTING has always been recognized by educated men as a subject of importance: there is no mechanical art, nor are there any of the fine arts, about whose *early history* so many volumes have been written. The *subject* is as mysterious as it is inviting. There is an unusual degree of obscurity about the origin of the first printed books and the

Lower case a to z, 11½ ems

ABCDEFGHIJKLMNOPQRSTUVWXYZ

1234567890

12 POINT OLD STYLE NO. 71

12A 6A 60a \$4 60

THE INVENTION OF PRINTING has always been recognized by educated men as a subject of great importance: there is no mechanical art, nor are there any of the *fine* arts, about whose *early history* so many volumes have been written. The subject is as mysterious

Lower case a to z, 11 5-6 ems

ABCDEFGHIJKLMNOPQRSTUVWXYZ

1234567890

14 POINT OLD STYLE NO. 71

18A 14A 52a \$5 25

THE INVENTION OF PRINTING has at all times been recognized by educated men as a subject of great importance: there is no mechanical art, nor are there any of the fine arts, about whose early history so many books have been written. The subject is as *mysterious* as it is inviting. There is an unusual degree of obscurity about the origin of the first printed books

ABCDEFGHIJKLMN OPQRSTU VW  
 1 2 3 4 5 6 7 8 9 0

18 POINT OLD STYLE NO. 71

18A 14A 52a \$8 30

THE INVENTION OF PRINTING has been recognized by educated men as a subject of great importance: there is no *mechanical* art, nor are there any of the fine arts, about whose early history so many books have been written. The subject is as difficult as it is inviting. There

ABCDEFGHIJKLMN OPQRST  
 1 2 3 4 5 6 7 8 9 0

Caslon Old Style No. 71

72 POINT

3A 3a \$14 05

Blonde

60 POINT

3A 4a \$10 45

Aid SIN

48 POINT

4A 6a \$8 50

BIG Delays

40 POINT

5A 10a \$8 35

Limbs SORE

36 POINT

7A 4A 14a \$9 35

ART SALE Open



**Caslon Old Style No. 71**

28 POINT

7A 4A 14a \$6 95

Brings FORTH Secrets  
FAMILIARITY

24 POINT

10A 7A 20a \$7 65

Honoring POE Unveiled  
MONUMENT

22 POINT

14A 10A 28a \$7 65

Historical NEWS Completed  
REPRODUCING

18 POINT

18A 14A 52a \$8 30

Imperial Palace of the Emperor  
BEAUTIFUL GALLERIES  
GORGEOUS SPLENDOR

14 POINT

14A 18A 52a \$5 25

Enthusiastic Demonstrations Prearranged  
CALISTHENIC EXERCISES  
JUVENILE EXCURSIONS

Caslon Old Style No. 71 Italic

48 POINT

3A 5a \$6 05

*Spring* **BUD**

40 POINT

4A 7a \$5 15

**NINE** *Bakers*

36 POINT

4A 8a \$4 60

*Singing* **BIRDS**

28 POINT

5A 10a \$3 60

**MODEL** *Expositions*

24 POINT

6A 14a \$3 35

*Advertisement* **PUSHED**

22 POINT

8A 18a \$3 15

**CLERICAL** *Demonstrations*

18 POINT

10A 28a \$3 40

*European* **HISTORIES** *Furnished*

14 POINT

18A 52a \$5 00

**FOREIGN GOODS** *Examined Minutely*

COPPER ALLOY TYPE

8 POINT FRENCH ELZEVIR NO. 1

THE INVENTION OF PRINTING has always been recognized by educated men as a subject of importance: there is no mechanical art, nor are there *any of the fine arts*, about whose early history so many books have been written. The subject is as mysterious as it is inviting. There is an unusual degree of obscurity about the origin of the first printed books and the lives and works of the

Lower case a to z, 12 $\frac{3}{4}$  ems

ABCDEFGHIJKLMNOPQRSTUVWXYZ

1234567890

10 POINT FRENCH ELZEVIR NO. 1

THE INVENTION OF PRINTING has always been recognized by educated men as a subject of importance: there is no mechanical art, nor are there *any of the fine arts*, about whose early history so many books have been written. The subject is as mysterious as it is in-

Lower case a to z, 12 ems

ABCDEFGHIJKLMNOPQRSTUVWXYZ

1234567890

12 POINT FRENCH ELZEVIR NO. 1

THE INVENTION OF PRINTING has always been recognized by educated men as a subject of importance: there is no mechanical art, nor are there *any of the fine arts*, about whose

Lower case a to z, 12 $\frac{1}{2}$  ems

ABCDEFGHIJKLMNOPQRSTUVWXYZ

1234567890

14 POINT FRENCH ELZEVIR NO. 1

THE INVENTION OF PRINTING has always been recognized by educated men as a subject of importance: there is no mechanical art, nor are there *inventions of*

DECIDEDLY PARTISAN

AMERICAN TYPE FOUNDERS CO.

6 POINT FRENCH OLD STYLE NO. 2

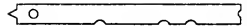

THE INVENTION OF PRINTING has always been recognized by educated men as a subject of importance: there is no mechanical art, nor are there any of the fine arts, about whose early history so many books have been written. The subject is as mysterious as it is inviting. There is an unusual *degree of obscurity* about the origin of the first printed books and the lives and works of the early printers. There are records and traditions which cannot be reconciled of at least three distinct inventions of printing. Its early history is entangled with a controversy about rival inventors which has lasted for more than three centuries, and is not yet fully determined. In the management of this controversy, a subject intrinsically attractive has been made repulsive. The history of the invention of printing has been written to please national pride. German authors assert the claims of Gutenberg, and discredit traditions about Coster. Dutch authors insist on the priority of Coster, and charge Gutenberg with

Lower case a to z, 14 ems

ABCDEFGHIJKLMN OPQRSTUVWXYZ

1234567890

7 POINT FRENCH OLD STYLE NO. 2



THE INVENTION OF PRINTING has always been recognized by educated men as a subject of importance: there is no mechanical art, nor are there any of the fine arts, about whose early history so many volumes have been written. The subject is as mysterious as it is inviting. There is an *unusual degree* of obscurity about the origin of the first printed books and the lives and works of the early printers. There are records and traditions which cannot be reconciled of at least three distinct inventions of printing. Its early history is entangled with a controversy about rival inventors which has lasted for more than three centuries, and is not yet

Lower case a to z, 14½ ems

ABCDEFGHIJKLMN OPQRSTUVWXYZ

1234567890

8 POINT FRENCH OLD STYLE NO. 2

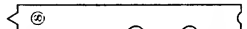

THE INVENTION OF PRINTING has always been recognized by educated men as a subject of importance: there is no mechanical art, nor are there any of the fine arts, about whose early history so *many volumes* have been written. The subject is as mysterious as it is inviting. There is an unusual degree of obscurity about the origin of the first printed books and the lives and works of the early printers. There are records and traditions which cannot be reconciled of at least three distinct inventions of printing. Its early history is entangled with a controversy about rival inventors which has

Lower case a to z, 13¾ ems

ABCDEFGHIJKLMN OPQRSTUVWXYZ

1234567890

COPPER ALLOY TYPE

10 POINT FRENCH OLD STYLE No. 2

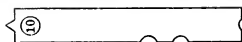

THE INVENTION OF PRINTING has always been recognized by educated men as a subject of importance: there is no mechanical art, nor are there any of the fine arts, about whose early history so *many volumes* have been written. The subject is as mysterious as it is inviting. There is an unusual degree of obscurity about the origin of the first printed books and the lives and works of the early printers. There are records and traditions which cannot be reconciled of at least three distinct inventions of printing. Its early history is entangled with a controversy about rival inventors which has lasted for more than three centuries, and is not yet fully determined. In the management of this controversy, a subject intrinsic-

Lower case a to z, 12 $\frac{2}{3}$  ems

ABCDEFGHIJKLMNOPQRSTUVWXYZ

1234567890

12 POINT FRENCH OLD STYLE No. 2

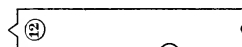

THE INVENTION OF PRINTING has always been recognized by educated men as a subject of importance: there is no mechanical art, nor are there any of the fine arts, about whose early history so *many volumes* have been written. The subject is as mysterious as it is inviting. There is an unusual degree of obscurity about the origin of the first printed books and the lives and works of the early printers. There are records and traditions which cannot be re-

Lower case a to z, 13 ems

ABCDEFGHIJKLMNOPQRSTUVWXYZ

1234567890

**FRENCH OLD STYLE No. 2**

15

72 POINT

3A 4a \$14 00

Homes

60 POINT

4A 5a \$12 50

ROADS  
Dusty

48 POINT

4A 7a \$8 50

MOTHER  
Hours 68

FRENCH OLD STYLE No. 2

15

36 POINT

5A 9a \$6 00

RICH TREES  
Christmas

30 POINT

7A 12a \$5 75

SUMMER TIME  
Gay Flowers

24 POINT

10A 20a \$5 75

PAINTED SCENES  
Great Masters 6

20 POINT

14A 28a \$5 50

BEAUTIFUL GARDEN  
Blooming Hyacinths

18 POINT

18A 36a \$5 00

ROYAL EUROPEAN PALACE  
Gorgeously Sparkling Rays

**FRENCH OLD STYLE No. 2**

—15—

12 POINT

20A 10A 60a \$5 00

SILVER MOONLIGHT ON THE LAKE  
GRACEFULLY GLIDES OUR BOAT  
Rippling Waters Sweetest Music Make

10 POINT

24A 12A 75a \$4 70

NATURE'S SWEET RESTORER, BALMY SLEEP  
TIRED AND WEARY WORKERS  
Early to Bed and Early to Rise Makes Health

8 POINT

30A 15A 90a \$4 60

TYPE OF EVERY DESCRIPTION MANUFACTURED  
TO ORDER ON SHORT NOTICE  
Unique and Cannot be Excelled by any Other Made

7 POINT

30A 15A 90a \$4 60

CONTAINS A DIRECTORY OF EVERY SOUL IN THE TOWN  
GIVING FULL NAME, AGE AND DESCRIPTION  
No Event will be too Small to Appear and Business Recorded

6 POINT

30A 20A 100a \$4 00

ENGLAND HAS TO UNDERGO THE REVOLT OF THE COLONIES  
TO SUBMIT TO DEFEAT AND SEPARATION  
And to Shake Under that Volcano of the French Revolution Grapple



## FRENCH OLD STYLE No. 2 ITALIC

15

12 POINT

16A 40a \$3 50

## THE REAL GENTLEMAN

*The Real Gentleman should be gentle in everything, at least in everything that depends on himself—in carriage, temper, constructions, aims, desires. He ought by all \$1234567890*

10 POINT

20A 50a \$3 00

## ABOUT UNDISCOVERED TRUTHS

*If Isaac Newton likened himself to a child on the seashore, gathering a few pebbles brighter than the rest, and humbly said that the great ocean of truth lay all undiscovered before him; who are we \$1234567890*

8 POINT

24A 60a \$2 75

## TIME FOREVER THE CRADLE OF HOPE

*It constantly flies, yet overcomes all things by flight; and although it is the present ally, it will be the future conqueror of Death. Time, the cradle of Hope, but the grave of Ambition, is the stern corrector of Fools, but is also the salutary \$1234567890*

7 POINT

24A 60a \$2 50

## ALL HONEST INDUSTRY HONORABLE

*There is no discredit, but honor, in every right walk of industry, whether it be in tilling the grounds, making tools, or weaving fabrics, or selling the products behind a counter. A youth may handle a yard-stick, or measure a piece of ribbon; and there will be 1234*

6 POINT

20A 45a \$2 25

## TIME TOO NARROW FOR THE 'DRAMA OF LIFE

*No monster of cruelty was ever dreamed of so monstrous as a Creator who could create this world and not continue it; create human beings with possibilities of accomplishment, with suggestions of happiness, and dash the cup from their lips while yet it is scarcely more than tasted. Even as it is, with the 1234567890*

CAXTON OLD STYLE

12

72 POINT

3A 5a \$15 50

Resort

60 POINT

3A 6a \$10 50

Dreams

48 POINT

4A 8a \$9 10

Mountain  
SHOE

36 POINT

5A 10a \$6 70

Born Grand  
MUSIC

CAXTON OLD STYLE

12

30 POINT

6A 12a \$5 15

HOME Friends

24 POINT

8A 16a \$4 90

MARINE Present

18 POINT

10A 20a \$3 65

Handsome 8 Romancer  
HARMONIOUS

12 POINT

18A 12A 50a \$4 75

Negotiated First Mortgage Payments  
CALM YOUR TEMPER  
SECOND NATIONAL BANKS

10 POINT

18A 12A 50a \$3 50

Modern Subject Traveling About the World  
PLEASANT BOAT RACES  
NEVER DISCOURAGE CHARITY

8 POINT

24A 18A 64a \$3 70

Unrelenting Criminals Receive Their Just Deserts  
FIREMEN SCARCELY ESCAPED  
EMBRACES ENTIRE DISTRICT BURNED

6 POINT

32A 24A 100a \$4 45

Large Black Eyes Were Sparkling Like Brazilian Diamonds  
SELECT GATHERING MONDAY NIGHT  
REGULATE NEWLY INVENTED MECHANISM

**CAXTON OLD STYLE ITALIC**

12

12 POINT

18A 100a \$5 70

*Printers Decide Historical Question*  
*Farmers with Money*  
**RESTORES HER FORTUNE**

10 POINT

24A 140a \$6 65

*Ignorance Rapidly Degenerates Character*  
*Pure Water Famine Ending*  
*Salutes Modest Officer*  
**HISTORIC CHICAGO SOCIETY 48**

8 POINT

32A 200a \$8 15

*Having Reached This Elevation They Returned*  
*Consider Subject Beautiful Indeed*  
*Inhumanity Among Turks*  
**RAVENOUS LOVE FOR GREEN BACKS**

6 POINT

32A 200a \$6 70

*Philanthropists Hold Churchmen Responsible for Good*  
*Many Industrious Pupils Advance Rapidly*  
*Education Among Laboring Class*  
**QUESTION DECIDED IMPARTIALLY 1234567890**

Old Style No. 83 Card Series

12

22 POINT

6A \$0 75

8A 16a \$3 50

Kentuckian Encouraged  
DEAD BIRDS

18 POINT

8A \$0 55

10A 20a \$2 95

Regulators Responded Promptly  
HOME 385 FARMS

12 POINT

25A 50a \$4 00

Dreaded Breakers Retreated Eastward  
PURCHASE COUCH

10 POINT

25A 75a \$3 80

Prominent Artisans Combine Without Greenbacks  
GOVERNED 967 CAVALRYMEN

8 POINT

30A 150a \$4 75

Elegant Home-Spun Linens Brought Direct From Germany  
Industries Bring Fortune  
WESTERN HARVESTERS WHISTLE 648

6 POINT

30A 150a \$4 00

Honorary Members Urgently Espoused the Minority Financial Report  
Chicago Banquets Eminent Diplomat  
ELEVATED RAILROAD STOCKHOLDERS ASSESSED

OLD STYLE ITALIC No. 83

12

42 POINT

3A 6a \$6 00

*Birds* **BOIL**

30 POINT

5A 10a \$5 00

*MAIN* *Reason*

24 POINT

8A 16a \$4 25

*Reimburse* *Railroader*  
**DEMONS**

22 POINT

8A 16a \$3 80

*Patriotic* *Man* *Carousing*  
*RUIN* 23 *FIRM*

18 POINT

10A 20a \$3 10

*Fortunate* *Stockholders* *Retired*  
*HOME* 467 *DESK*

**OLD STYLE ITALIC No. 83**

12

12 POINT

20A 40a \$3 05

*The Invention of Printing has always been recognized by educated men as a subject of great importance: there is no mechanical art, nor are there any of the fine arts about whose early history so many fine books have been written* \$1234

**INVENTION OF PRINTING**

10 POINT

20A 40a \$2 40

*The invention of Printing has been recognized by men of education as a subject of great importance: there is no mechanical art, nor are there any of the fine arts about whose early history so many books have been written. The subject is as mysterious as it is inviting. There is an unusual degree of obscurity about the origin* \$3678

**THE INVENTION OF PRINTING**

8 POINT

25A 75a \$2 95

*The Invention of printing has been recognized by men of education as a subject of importance: there is no mechanical art, nor are there any of the fine arts about whose early history so many books have been written. The subject is as mysterious as it is inviting. There is an unusual degree of obscurity about the origin of the first printed books and lives and works of the early printers. There are records and traditions which cannot be reconciled of at least three distinct inventions* \$12345

**THE INVENTION OF BOOK PRINTING**

6 POINT

25A 75a \$2 40

*The Invention of Printing has been recognized by men of education as a subject of importance: there is no mechanical art, nor are there any of the fine arts about whose early history so many books have been written. The subject is as mysterious as it is inviting. There is an unusual degree of obscurity about the origin of the first printed books and lives and works of the early printers. There are records and traditions which cannot be reconciled of at least three distinct inventions of printing. Its early history is entangled with a controversy about rival inventors which has* \$1234

**THE INVENTION OF BOOK PRINTING HAS**

FRENCH OLD STYLE No. 1

15

72 POINT

3A \$8 40

FINED

60 POINT

4A \$7 60

CHART

48 POINT

4A \$4 50

MARKED

36 POINT

5A \$3 00

HAND NOW

30 POINT

7A \$2 90

BRIGHT CASH



FRENCH OLD STYLE No. 1

15

24 POINT

10A \$2 80

MIRTHFUL MUSIC

20 POINT

14A \$2 70

LIGHTNING EXPRESS

18 POINT, ALSO CAST ON 16 POINT

18A \$2 50

NORWEGIAN IMMIGRATION  
COUNTRY STRANGER 78

14 POINT

20A \$2 30

BASKING IN BRIGHT SUNLIGHT  
GLORIOUS MORNING 84

12 POINT

20A \$1 55

PLUCKED BLOSSOMING WHITE ROSE  
EMBLEM OF INNOCENCE 76

10 POINT

24A \$1 60

DELIGHTFUL LAKESIDE SCENERY ADMIRER  
VIEWS FROM EXCURSION BOATS 63

8 POINT

30A \$1 65

ENTERTAIN NATIONAL HOSTLERS' ASSOCIATION  
DELEGATES TO STABLEMEN'S MEETING

6 POINT

30A \$1 25

ENGLAND HAD TO UNDERGO THE REVOLT OF THE COLONIES  
AFTER ENACTMENT OF UNJUST LAWS \$1234567890

OLD STYLE No. 43

40 POINT

5A \$4 60

HONIED

36 POINT

5A \$3 80

BURNISH

28 POINT

8A \$3 60

ROMANTIC

24 POINT

10A \$3 45

NINE 28 LOST

22 POINT

12A \$3 05

ORDER CLOAK

20 POINT

12A \$2 85

BRIGHT MOONS

16 POINT

14A \$2 40

BUYING 167 HOMES

12 POINT

18A \$1 95

TRYING HONEST PERSON

OLD STYLE TWO-LINE

15

24 POINT

12A \$3 00

SMILING MAID  
CHEERFUL

20 POINT

14A \$2 50

BURIED A MISER  
UNMOURNED

16 POINT

16A \$2 00

RAILROAD FOLDERS  
PECULIAR MAPS

12 POINT

16A \$1 50

MAKE RELIABLE RECORD  
HONEST HISTORIANS

EDINBURGH TITLE

—15—

36 POINT

7A \$4 65

EXERCISE

24 POINT

10A \$3 00

MESSENGERS

20 POINT

12A \$2 50

INSPECT STEAM

16 POINT

18A \$2 00

BELIEVE PROFESSOR

14 POINT

18A \$2 00

PRONOUNCING LETTERS

12 POINT

16A \$1 50

NOVEL ROMANCES WRITTEN  
DEVOUR WEIRD STORIES

10 POINT

20A \$1 50

PHONOGRAPHICAL SIGN ELEMENTS  
SOUND CHARACTERS 36

9 POINT

22A \$1 50

TABLES OF FRENCH METRICAL SYSTEM  
SIMPLE WEIGHTS AND MEASURES

OLD STYLE CONDENSED No. 40

36 POINT

7A \$3 60

HISTORIAN

28 POINT

10A \$3 85

RESENTMENT

24 POINT

12A \$3 50

PUBLIC HOUSES

22 POINT

16A \$3 70

RESORTS OPENED

20 POINT

18A \$3 70

ELECTION REPORT

18 POINT

22A \$3 30

HEROISM 862 SOLDIERS

16 POINT

22A \$3 10

RESERVED NEIGHBORS

14 POINT

22A \$2 75

MOUNTAIN 27 LANDSCAPE

12 POINT

30A \$2 50

10 POINT

36A \$2 35

HOLES BORED | EXPERT MARKED

OLD STYLE CONDENSED No. 120

42 POINT

4A \$2 75

NEIGHBORS

36 POINT

5A \$2 85

SURE CRIME

32 POINT

6A \$2 55

EXTENSIVELY

30 POINT

8A \$2 40

DEMONSTRATED

24 POINT

8A \$1 95

LIQUID 45 KNOWN

22 POINT

10A \$1 90

FORMERLY CHICAGO

**OLD STYLE CONDENSED No. 120**

—12—

20 POINT

12A \$2 00

MASTERED QUIETLY

18 POINT

16A \$2 00

BUTCHERED UNDERHAND

16 POINT

16A \$1 55

NORTHEASTERN ADVENTURES

12 POINT

18A \$1 35

FREQUENT YEARNED REMAINDER

10 POINT

24A \$1 30

GRANTED GROCERS ADEQUATE DOCKAGE  
GRUMBLING HARMONIOUS

9 POINT

24A \$1 15

GLORIOUS ANTHEMS OUTLYING SUREST THEMES  
HARMONIOUS 48 GATHERING

8 POINT

32A \$1 25

HONORABLE CONGRESSIONAL DIPLOMATS ATTRACTIVELY  
DISTRIBUTING GREATER EMOLUMENTS

OLD STYLE CONDENSED No. 122

—12—

72 POINT

3A 5a \$9 50

3A \$4 65

RED Bird

60 POINT

3A 6a \$7 95

3A \$3 50

FINE Show

48 POINT

3A 6a \$5 75

3A \$2 45

MEN 68 Liver

44 POINT

3A 6a \$4 80

3A \$2 00

END NOT Sure

42 POINT

3A 6a \$3 85

3A \$1 75

UNTOLD Wealth

SMALL CAPS NOT SENT UNLESS EXPRESSLY ORDERED



OLD STYLE CONDENSED No. 122

—12—

36 POINT

4A 8a \$3 70      4A \$1 45

MORE GUIDE Here

★ 30 POINT

7A 11a \$4 50      5A \$1 25

REASONS Desired 86

24 POINT

6A 12a \$2 65      6A \$1 00

BRIGHT STONE Colors 8

20 POINT

8A 16a \$2 55      8A \$1 00

GREATER GERMANS Advance

18 POINT

10A 20a \$2 50      10A \$0 90

Freedom is Declared Shrieked 465  
GROTESQUE FORMALITIES

12 POINT    16A 32a \$2 00    16A \$0 80

Producing Everything  
ROMANCE WAVES

10 POINT    20A 40a \$2 05    20A \$0 75

Grangers Beauty Displays  
GRAND MODELS

9 POINT

24A 48a \$2 15

Display Courageous Abilities  
MODERN CELEBRANTS

8 POINT

32A 64a \$2 65

Touching Anomalous Questions  
MANY DEVIATING WAYS

SMALL CAPS NOT SENT UNLESS EXPRESSLY ORDERED

OLD STYLE CONDENSED No. 4

10

48 POINT

6A 10a \$5 60

Clothing 21 DEALER

40 POINT

6A 10a \$4 05

SHOCKING 52 Accidents

36 POINT

10A 15a \$4 50

Unfortunate 96 CANDIDATE

24 POINT

15A 20a \$3 60

NEWSPAPER 782 Advertisement

18 POINT

20A 30a \$3 30

78 Summer Night and the Bright Moonshine  
FOND RECOLLECTIONS

12 POINT

25A 40a \$2 40

Upon Countless Unhappy Mortals Residing Below 725  
FROM GOD GREAT BLESSINGS FLOW

Old Style Latin Condensed No. 30

48 POINT

5A 8a \$4 85

**STEEL Mechanism**

40 POINT

5A 10a \$4 15

**BRIGHT Winter Scene**

36 POINT

8A 12a \$3 80

**BUSINESS Reform Method**

24 POINT

12A 20a \$3 65

**Rare Modern Christmas Presents  
CUSTOMARY CURIOSITIES**

18 POINT

20A 30a \$3 40

**Professional Medical Oratorical Discussion  
OPERATIVE SURGICAL REVIEW**

12 POINT

25A 40a \$2 45

**Useful Scientific Examination of Geological Specimens  
AMERICAN MINERALOGICAL RESEARCHES**

OLD STYLE EXTENDED

15

48 POINT

4A 6a \$13 00

4A \$4 75

GIVES

First

36 POINT

4A 6a \$6 00

4A \$2 50

PONTIFF

Regard

24 POINT

6A 10a \$5 00

6A \$2 00

GOVERNORS

Execution

Rich 5 Mine

SMALL CAPS NOT SENT UNLESS SPECIALLY ORDERED

OLD STYLE EXTENDED

15

18 POINT

9A 12a \$3 50

9A \$2 00

TEACHES MUSIC  
Short Month  
Summer Hours

12 POINT

14A 22a \$3 50

14A \$1 50

SECOND GRAND BALL  
Classical Concert  
Fancy Dress Occasion

10 POINT

16A 22a \$3 00

16A \$1 25

RUN IF YOU LIKE BUT TRY  
Worked to Death  
Graduating 25 Exercises

8 POINT

20A 30a \$3 00

16A \$1 00

HORSEMEN DIRECTED NORTH  
Furnaces and Ranges  
Long Sings the Old German Poet

6 POINT

24A 30a \$2 75

BREATHES THERE A MAN WITH SOUL  
Who Never Dead to Himself  
Grand Display of Christmas Presents

**PARTHENIAN SERIES**

—12—

72 POINT

3A 6a \$17 25

China

60 POINT

3A 5a \$12 10

Route

48 POINT

3A 6a \$9 60

Counter  
HOE

36 POINT

4A 8a \$6 50

Nonsense  
HOUR

**PARTHENIAN SERIES**

—12—

24 POINT

6A 12a \$4 65

Course 4 Chains  
FARMING

18 POINT

8A 16a \$4 15

Eleven Daises 34  
METEORS

12 POINT

12A 24a \$3 00

Monument 34 Columbian  
WINTER DISPLAY

10 POINT

16A 32a \$2 60

78 Machines Hurriedly Improved  
EASTERN STABLES

9 POINT

16A 32a \$2 55

Holiday Number Ready November  
ECONOMICAL HEATHEN

6 POINT

24A 48a \$2 75

Performances Under Unfavorable Conditions  
PAUL BOYTONS EXHIBITION

**CAXTON BOLD**

—12—

72 POINT

3A 5a \$15 00

ENter

60 POINT

3A 6a \$11 75

MISuse

48 POINT

4A 8a \$9 50

ENGines

36 POINT

5A 10a \$8 50

PRODuctive

30 POINT

6A 12a \$5 60

FROG 4 Brown



**CAXTON BOLD**

—12—

24 POINT

8A 16a \$4 90

**Printers Measure  
FRENCH**

18 POINT

10A 20a \$3 85

**Enormous 5 Cosmetics  
HERODITUS**

12 POINT

18A 36a \$3 40

**Demonstrate Combined Requisitions  
METEORIC 86 FORMATIONS**

10 POINT

20A 40a \$3 00

**Extraordinary Diplomatic Functionaries  
GOVERNMENT PRODUCTION**

8 POINT

24A 48a \$3 20

**Elucidate Aristocratic Fashionable Companion  
56 BURNING ELOQUENCE**

6 POINT

24A 48a \$2 60

**Demonstrated Superiority 24 Intelligent Combinations  
HETEROGENEOUS MISCALCULATIONS**

CUSHING OLD STYLE

15

48 POINT

4A 6a \$7 00

**HIGH Gate**

36 POINT

5A 8a \$5 50

**RISES Earlier**

24 POINT

8A 12a \$4 50

**BROKE the Bankers**

18 POINT

12A 16a \$3 50

**PERFECTION Guaranteed**

14 POINT

16A 24a \$3 25

**Harmonious Sounds Issuing Forth  
Enough for Universe  
SEND THE JOYFUL NEWS**

12 POINT

20A 30a \$3 00

**When Freedom from Her Mountain Height  
Admire Her Long Braid  
UNFURLED HER STANDARD**

**CUSHING OLD STYLE**

— 15 —

11 POINT

22A 34a \$2 90

Whenever in the Ordinary Course of Events it  
Becomes Absolutely Necessary  
**NATIONAL BOUNDARIES CHANGE**

10 POINT

24A 36a \$2 75

Corrected Time Tables have been Issued from Time  
to Time But Still in Spite of All  
**DISASTROUS WRECKS OFTEN OCCUR**

9 POINT

28A 42a \$2 75

The Deeds of Heroes have been Told in Prose and Poem  
Ever since the World was Young  
**PAUL REVERE WAS A RIDER BOLD**

8 POINT

28A 42a \$2 50

The World may be Growing Wiser and Weaker, but it Surely  
Has Far to go to Reach the Limit  
**PRIZE FIGHTERS ARE STRONG AND BRUTAL**

7 POINT

26A 40a \$2 50

To Him Who in the Love of Nature Holds Communion with Her  
Visible Forms, She Speaks a Various Language  
**BOOKS IN RUNNING BROOKS, SERMONS IN TREES**

6 POINT NO. 1

24A 36a \$2 25

A Very Interesting Item of News and one That Seems to be Dished Up in  
All Kinds of Style by Metropolitan Papers  
**MOODY'S GREAT REVIVAL MEETINGS IN NEW YORK**

LATIN ANTIQUE No. 120

48 POINT

3A 5a \$7 70

BURners

36 POINT

4A 8a \$5 90

NEW Hose

30 POINT

6A 12a \$5 35

Harm 5 Beans  
MOUNDS

24 POINT

8A 16a \$4 50

Restored Monarch  
REMAINS

18 POINT

10A 20a \$3 65

French Soldier Rushing  
ELECTRICIANS

**LATIN ANTIQUE No. 120**

12

12 POINT

12A 24a \$2 45

Montana Stock Raisers Reunion  
December Eleventh  
**CHARMING CREATURES**

10 POINT

18A 36a \$2 95

Beautiful Christmas Presents Given  
Elegant Display Goods 54  
**UNITED STATES SECURITIES**

8 POINT

24A 48a \$3 00

Metropolitan Accident Insurance Companies  
Educational Institutions  
**READING BECOMING IMPORTANT**

6 POINT

24A 48a \$2 60

American Type Founders Company Would Kindly  
Invite Your Attention 34567  
**HUDSON RIVER STEAMBOAT COMPANY**

5 ON 6 POINT

24A 48a \$2 15

Specimens Modern Inventions in Lithographing and Engraving  
Establishments During Past Years 857  
**MANHATTAN SOCIALS GRAND ENTERTAINMENT**

**OLD STYLE ANTIQUE**

4-12

48 POINT NO. 40

4A 6a \$8 00

**Managers  
HOME**

36 POINT NO. 40

6A 9a \$7 10

**Stone House  
GRAND**

30 POINT NO. 40

8A 12a \$6 00

**Deliver Reports  
MARINES**

24 POINT NO. 120

8A 16a \$5 80

**First Annual Sale  
RIBBONS**

OLD STYLE ANTIQUE

20 POINT NO. 120

10A 20a \$4 60

Nineteen Exhibitions  
INTRODUCED

18 POINT No. 120

12A 24a \$4 30

Confidence 4 Stockholders  
NATIONAL BANK

12 POINT NO. 120

16A 32a \$2 85

Strongest Protests Against Reducing  
RAILROAD RATES 485

10 POINT No. 120

18A 36a \$2 35

Mans Inhumanity to Man Makes Countless  
Thousands Mourn Burns 123  
GOVERNMENT APPLICATIONS

8 POINT No. 120

20A 40a \$2 10

Chasteness and Purity in Language Always Desirable  
Uprightness and Sincerity  
GRACEFULNESS UNITED TO ELEGANCE

6 POINT No. 120

24A 48a \$2 00

Beautiful Sunsets Appearing to an Enraptured Observer of Nature  
Now the Hush of Twilight Falls 456  
GENTLY ON THE GREEN AND SLOPING MEADOWS

Old Style Antique No. 112

48 POINT

4A \$5 00

SOUPS

42 POINT

5A \$4 80

FINGER

36 POINT

7A \$4 50

BUNTING

24 POINT

10A \$3 75

TACK POINT

20 POINT

12A \$3 15

BLUE VIOLET 5

18 POINT

14A \$2 45

2 CHICKEN POTPIE

12 POINT

18A \$1 80

LARGE NOTION HOUSE 7



OLD STYLE BOLD

15

48 POINT

4A 6a \$15 00

**Ran 8**

36 POINT

4A 6a \$9 50

**7 Mires**

24 POINT

5A 7a \$6 00

**HIS Count**

18 POINT

7A 9a \$4 50

**Ground FOUR**

12 POINT

12A 16a \$4 00

**Dealer £24 Howled  
PANORAMA**

10 POINT

14A 18a \$3 50

**Economic \$5 Discourses  
ACKNOWLEDGED**

8 POINT

16A 22a \$3 50

**Lady Rider 375 Fine Habits  
EQUESTRIENNE**

6 POINT

16A 22a \$3 00

**Hail Freedom 846 Patriotic Men  
BIG HIPPOPOTAMUS**

**French Old Style Extended**

12

72 POINT

3A 5a \$12 50

Horse

60 POINT

4A 5a \$11 75

Record

48 POINT

4A 5a \$7 50

Demons

36 POINT

5A 10a \$4 75

Hard 4 Cash  
BRICKS

**French Old Style Extended**

—12—

30 POINT

5A 10a \$4 75

Brave Heroes  
MOURN

24 POINT

6A 12a \$4 00

Record 5 Breaker  
CHARMING

18 POINT

8A 16a \$3 00

Handsome 3 Number  
EXCURSION

12 POINT

15A 30a \$2 75

Eastern Telegraph Company  
REFUSE CONTRACT

10 POINT

18A 36a \$2 75

Unfortunate Speculator Recuperating  
European Countries  
QUESTIONS 36 ANSWERED

CONDENSED SERIES

12

★72 POINT No. 45

5A \$9 85

STRONG

48 POINT No. 124

4A \$4 05

REVENUE

42 POINT No. 124

5A \$2 90

ENTER PORTS

36 POINT No. 124

6A \$2 70

MORSE 5 BRUSH

30 POINT No. 124

10A \$2 80

REPORT SOLDIER

24 POINT No. 124

12A \$2 20

ORPHEUS 8 REMORSE

CONDENSED SERIES

12

18 POINT No. 124

16A \$2 00

HOMERIC NERO DEMERITS

16 POINT No. 124

18A \$2 00

DRAINAGE EASY PRODUCED

12 POINT No. 124

24A \$1 85

HISTORY WOULD COVER MUCH  
FAMOUS 65 CAPTAIN

11 POINT No. 124

24A \$1 50

REVISED TABLES CONTAIN FIGURES  
12 POINT FINGER NORTH 34

10 POINT No. 124

24A \$1 35

HIGH LIVING DESTROYS THEIR HEALTH  
56 EIGHTY NUMBERS 78

8 POINT No. 124

24A \$1 15

RECITING PLEASANT STORY MADE PROFITABLE  
CONCISE FORM MODELS DONATED

6 POINT No. 124

36A \$1 30

HEROICALLY SAVED THEMSELVES FROM IGNOMINIOUS DEFEAT  
FATIGUED SOLDIERS MARCHING  
12 WONDERFUL CENTENNIAL EXPOSITION 34

**TWO-LINE LETTER**

3-12

48 POINT No. 35

5A \$5 50

RIGHTS

40 POINT No. 35

5A \$4 65

HERMIT

36 POINT No. 35

6A \$3 80

TERMINUS

30 POINT No. 124

12A \$4 50

EXTEMPORE

24 POINT No. 124

12A \$3 40

METAL

22 POINT No. 124

12A \$2 80

TRAMPS

20 POINT No. 124

12A \$2 70

LENGTH

18 POINT No. 124

12A \$2 15

BARONET

16 POINT No. 124

16A \$2 25

POLEMICS

14 POINT No. 124

18A \$2 20

EMPORIUM

12 POINT No. 124

24A \$2 10

DEMOCRATIC

11 POINT No. 124

24A \$1 75

DEMOSTHENES

10 POINT No. 124

24A \$1 55

MONETIZATION

9 POINT No. 124

24A \$1 35

BRIGHT CHARMER

**TWO-LINE LETTER No. 129**

—12—

24 POINT

8A \$2 10

**RECALCITRATE**

18 POINT

12A \$1 90

**MUNICIPAL LEAGUE**

16 POINT

12A \$1 50

**STUDENTS GRADUATE**

12 POINT

16A \$1 50

**PHYSICIANS 4 SURGEONS**

11 POINT

16A \$1 35

10 POINT

22A \$1 50

**DOG SHOW 63 | VOCAL 78 MUSIC**

**TWO-LINE LETTER No. 128**

—12—

16 POINT

16A \$2 30

**ENLIGHTEN STUDENT**

14 POINT

18A \$2 20

**MISCHIEVOUS CRIMINAL**

12 POINT

24A \$2 20

**MUSICAL SCORING ABILITY**

11 POINT

24A \$1 95

**GOVERNMENT PRODUCTION 58**

10 POINT

24A \$1 60

**UNDERSTANDING 5478 WESTERN**

HALF TITLE SERIES

12

16 POINT No. 120

18A \$2 95

ENGLISH GENERAL

14 POINT No. 120

18A \$2 45

HOPEFUL 4 SCHEMES

12 POINT No. 120

24A \$2 50

FORTY MICE CAUGHT 6

11 POINT No. 120

24A \$2 15

7 BUILDING ON HIS HOPES  
WEAK FOUNDATION

10 POINT No. 120

24A \$1 70

STEALING OUR ARMY RATIONS  
123 HORSES AND MULES

8 POINT No. 120

32A \$1 85

NOT MANY CONSTANTLY TREAD UPON  
59 HONOR HER MEMORY MORE

8 POINT No. 122

16A 32A \$2 30

TRY SOUR MASH STRANGLING THE MURDERERS  
POUNDED WITCH POISON 23568

6 POINT No. 120

48A \$2 10

POETICAL HISTORY OF THE LATEST INDIAN WAR  
EDITED BY JUMPING BEAVER 84



**TW@-LINE No. 151**

15

24 POINT

10A \$3 00

BOOK BUYERS

20 POINT

10A \$2 50

PROUD WOMEN

18 POINT

11A \$2 25

FLORID SPEECH

16 POINT

12A \$2 00

LONGEST SERMON

14 POINT

14A \$2 00

NOCTURNAL DREAM

12 POINT

16A \$1 75

COMMERCIAL REPORTER

10 POINT

16A \$1 50

PRACTICAL MECHANOGRAPHY

9 POINT

18A \$1 50

UNIFORM SYSTEM OF TYPE BODIES

**LIGHT-FACE No. 158**

30 POINT

7A 8a \$5 00

ROME Maidens

24 POINT

8A 12a \$4 50

Building DANED

20 POINT

12A 16a \$4 00

GOLD Pendant Make

18 POINT

15A 20a \$3 50

FINE LACE Furnishers

12 POINT

20A 30a \$3 25

MAGAZINES AND PERIODICALS  
Weekly and Monthly Issues

10 POINT

24A 32a \$3 00

TRICYCLE RIDERS' RACING RULES  
Secured Distance Championship

8 POINT

24A 36a \$2 75

COLLECTIONS OF AMERICAN LITERATURE  
Library Endowment Fund 67

6 POINT

30A 40a \$2 50

REMINISCENCES OF THE RECENT UNPLEASANTNESS  
Rebellion Records Augmented Several Monthlies

UNIVERSITY SERIES

15

18 POINT

9A 20a \$3 50

SIMPLEST FASHIONS

Artistic decorations rarely are the most elaborate, but should display the \$1234

12 POINT

12A 28a \$3 00

SUPERIOR TYPOGRAPHY

We would call the attention of all printers and publishers to this new series, which is especially adapted for use on editions de luxe and other artistic books and \$1234567

10 POINT

16A 36a \$2 75

APPROBATION IS MERITED

That this is the handsomest of all the light-face Romans every printer will admit at first glance, which leads us to expect a large number of orders for fonts of all sizes and will appreciate useful face \$123456

8 POINT

20A 44a \$2 75

PLAIN AND CHASTE STYLE SHOWN

Many printers and not a few of their customers have complained that the type faces produced of late were much too grotesque. It has always been our endeavor to satisfy all tastes, and therefore this new Roman is now offered \$123456789

**BOLDFACE SERIES**

—11-12—

★48 POINT NO. 114

4A 4a \$6 30

**RED Bird**

★36 POINT NO. 114

4A 8a \$5 20

**PINE Boards**

30 POINT NO. 120

6A 12a \$5 25

**Market Baskets  
HUNTERS**

24 POINT NO. 120

10A 20a \$4 85

**Retired Army Officer  
HARD 41½ BEDS**

18 POINT NO. 120

12A 24a \$4 55

**Elevated Road Director  
UNPREPARED**

**BOLDFACE No. 120**

—12—

12 POINT No. 120

12A 24a \$2 60

**Elaborate Tariff Estimates 189  
HUNTS LOST YOUTH**

11 POINT No. 120

18A 36a \$2 90

**Double Reputation Daily Regenerated  
ELEGANT BRONZE SAMPLES**

10 POINT No. 120

18A 36a \$2 80

**Children Wanted Practical Knowledge  
TURBULENT WINDS RAGING**

9 POINT No. 120

24A 48a \$3 00

**Bank Depositor Coerced Them Into Payment  
FLORIDA TRANSIT COMPANY**

8 POINT No. 120

24A 48a \$3 10

**Marketable Products for Merchants Received  
SELECTING POETIC COLLECTION**

7 POINT No. 120

24A 48a \$2 60

**Wonderful Stories Recited About Brazilian Explorers  
INCREASED TRAVELING FACILITIES**

6 POINT No. 120

24A 48a \$2 30

**Haste Makes Waste and Ancient Adage Never Proved Truer  
FLEXIBLE MEMORIES SOUNDLY DEVELOPED**

5½ POINT No. 120

24A 48a \$2 65

**Properly Conducted Services Every Sunday Evening at Seven  
NATIVES STARTLED OVER INSURRECTION**

**BOLDFACE ITALIC No. 120**

—12—

30 POINT

6A 12a \$4 55

***BOSTON Failure***

24 POINT

10A 20a \$4 55

***PRINTS 4 Magazines***

18 POINT

12A 24a \$3 90

***35 BROWN Mantel Figures***

12 POINT

12A 24a \$2 65

***FORTUNE Divided Between 2***

11 POINT

18A 36a \$3 05

***6 MUNIFICENCE Embodied Therein***

10 POINT

18A 36a \$2 90

***NEGRO STRIFE Engenders Danger 5***

9 POINT

24A 48a \$2 95

***Hope Withering Fled and Mercy Sighed Aloud***  
***78 FUNERAL SERVICES***

8 POINT

24A 48a \$3 00

***Thousands Fiercely Storming Chinese Batteries***  
***POISONOUS IMPLEMENTS 532***

7 POINT

24A 48a \$2 55

***Revolving Mechanicalism***  
***HOMOGENEOUS 1234***

6 POINT

24A 48a \$2 25

***Engineers Open the Throttles***  
***5678 DISASTER COMES***

OPEN TITLE No. 120

16 POINT

12A 24a \$3 65

**NEW HEROIC Sentiment**

12 POINT

12A 24a \$2 55

**Doubtful National HISTORY**

11 POINT

18A 36a \$3 00

**GOVERNMENTS Combined Against**

10 POINT

18A 36a \$2 90

**Intersecting Decorations Dexterously  
MARKED 85 SCENERY**

9 POINT

24A 48a \$2 85

**Grand Barbacue on the Twentieth Anniversary  
WESTERN 5678 CONTAMINATING**

8 POINT

24A 48a \$2 95

**Money Loaned on Real and Personal Property  
TIGHTGRIP PINCHING COMPANY**

7 POINT

24A 48a \$2 25

**In Advertisements We Rely on Our Face Which Looms Up  
NEWSPAPER WORK 123 EXCEPTED**

6 POINT

24A 48a \$2 20

**Decorations Dexterously Interwoven to Deceive the Women  
NATURAL AND ARTIFICIAL**

5½ POINT

24A 48a \$2 00

**The Nine Sizes in this Series Modestly Bespeak for Themselves Utility  
COMMENDABLE 1893 CLEAN CUT FACES**

EXTRA CONDENSED

23

120 POINT No. 234

3A 6a \$12 50

LONG Theatre

96 POINT No. 234

4A 8a \$11 00

Tasteful and REAL

72 POINT No. 234

5A 10a \$10 50

Men Judge ACTIONS



**EXTRA CONDENSED**

—12—

48 POINT NO. 123

4A 8a \$5 80

Honorable Publication  
DISCONTINUE

42 POINT NO. 123

5A 10a \$4 80

Executed Beautiful Pictures  
21 MERCY SHOWN 43

36 POINT NO. 123

6A 12a \$4 70

United States 1234 Hearts Pined  
FOUGHT FOR RICHES

**EXTRA CONDENSED**

—12—

24 POINT NO. 123

8A 16a \$3 65

Handsome Collection Ancient Literature  
**EDUCATIONAL STATEMENT**

20 POINT NO. 123

10A 20a \$3 10

Startling Telegrams Concerning Japanese Powers  
**ELEVENTH INSTRUMENTAL RECEPTION**

18 POINT NO. 123

12A 24a \$3 00

Important Questions Answered Regarding Printers Treasury  
**MANUFACTURING 34529 MERCHANDISE**

14 POINT NO. 123

12A 24a \$2 55

Numerous Contented Farmers Viewing Their Harvests Thinking  
**BEAUTIFUL SPECIMENS STANDARD WRITERS**

12 POINT NO. 123

16A 32a \$2 65

Handsome Proportioned Cosmopolitan Underground Railroad Stations  
**BADLY MANAGED CANDLE HOUSES SUSPEND**

★10 POINT NO. 123

30A 40a \$3 10

This Work Will Give Relief in the Most Hopeless Cases and Consolation When in Despair  
**USEFUL HOUSEHOLD MANUAL FOR LEAP YEAR VICTIMS**

★8 POINT NO. 123

40A 50a \$3 50

Geneological Researches Prove that He Worked for a Living and Consequently the Amalgamated  
**POOR BENJAMIN FRANKLIN GREATLY EMBARRASSED BECAUSE**

CONDENSED TITLE No. 124

14 POINT

18A 36a \$3 70

Shoemakers Protective Associations  
COMPOUND FRACTURE

12 POINT

18A 36a \$3 05

Manufacturers Annual Ratifications 48  
MONSTER BANQUET

11 POINT

18A 36a \$2 60

37 Financial Question Advocates Economies  
DESTROY GIGANTIC SCHEMES

10 POINT

24A 48a \$3 30

Thirteen Meritorious Conditions Existed 26  
HUMOROUS SKETCHES

9 POINT

24A 48a \$2 75

49 Merchants Detectives Frustrated Counterfeiters  
SPLENDID ARTIFICIAL FIREWORKS

8 POINT

24A 48a \$2 50

Undisputed Champion Interpreter Translated Words 37  
SATISFACTORY EXPLANATIONS

7 POINT

24A 48a \$2 05

42 Great Difficulties Encountered Exploring Territories  
EASTBOUND STEAMSHIP PASSENGER

6 POINT

24A 48a \$2 05

Periodicals Including Varied Imposing Introductory Sketches 45  
PROMINENT CHICAGOIANS VACATIONS

CONDENSED TITLE

4-12

★ 72 POINT NO. 46

5A 6a \$16 95

MENtors

60 POINT NO. 125

3A 6a \$8 35

DEMocrats

48 POINT NO. 125

4A 8a \$6 40

METZ 8 Bonds

36 POINT NO. 125

8A 16a \$8 60

ROUTES Honest 58

30 POINT NO. 125

10A 20a \$4 90

54 COURAGE Diamonds

24 POINT NO. 125

12A 24a \$4 00

ENCOURAGES Monarchies 52

CONDENSED TITLE No. 125

—12—

18 POINT NO. 125

12A 24a \$3 25

MONUMENTAL 15 Protectionists

14 POINT NO. 125

18A 36a \$3 25

REPENTANCE Has Not Been Dated

12 POINT NO. 125

18A 36a \$2 75

PRAISE ATTENDING Pomp and Power 2

11 POINT NO. 125

18A 36a \$2 40

NATURE IS LIBERAL to Her Inmost Soul 48

10 POINT NO. 125

24A 48a \$3 00

HOW LOVELY LASTING PEACE OF MIND  
Sweet Delight of Human Kind

9 POINT NO. 125

24A 48a \$2 50

WITH ELOQUENCE INNATE HIS TONGUE IS ARMED  
And Draws his Audience Upward to the Sky

8 POINT NO. 125

24A 48a \$2 55

RICH WAS HIS SOUL THOUGH HIS ATTIRE POOR  
God hath Clothed his own Ambassador

7 POINT NO. 125

24A 48a \$2 00

OPPORTUNITIES MAKE US KNOWN TO OURSELVES AND OTHERS  
The Man that Hath no Music in Himself nor is Moved

6 POINT NO. 125

24A 48a \$2 05

ALL IMPROVEMENTS IN THE PRODUCTIVE POWERS OF LABOR  
With Division of Employment Depend on Cooperation

CONDENSED TITLE No. 123

12-15

★ 54 POINT

4A 5a \$8 00

KEY Club

★ 48 POINT

4A 6a \$7 00

LION Lame

42 POINT

5A 10a \$7 55

HARD Game

36 POINT

6A 12a \$7 15

MODES Shrink

30 POINT

8A 16a \$5 50

GLORY Exhibited

24 POINT

12A 24a \$4 75

GENTILITY Hysterical

18 POINT

10A 20a \$3 05

ENCOUNTER ? Transcription

**CONDENSED TITLE No. 123**

14 POINT

12A 24a \$2 60

**Receive Here Extra Grand Hounds  
CUMBERLAND MOUNTAIN**

12 POINT

18A 36a \$3 10

**Courageous Soldiers Power Establish  
Foreigners Compelled 42  
IRRIGATION NOW COMPLETE**

10 POINT

24A 48a \$2 95

**Surprising Controversies Enumerate Casualties  
48 Foretold Unquestionably  
UNDOUBTED RESPONSIBILITIES**

8 POINT

24A 48a \$2 50

**Thousand Thoughtful Entertainments More Interesting  
Quotient Interests Combined 70  
COMMODIOUS MALES GROSSLY OBEYED**

6 POINT

24A 48a \$1 95

**Manufacturing Interests Relating Financially to Gubernatorial Purpose  
Commemorate Established Home Securities  
ENERGETIC MACHINES PHILOSOPHICALLY HANDLED**

5 POINT

32A 64a \$2 40

**Organic Substances Combined with Celestial Objects to Illuminate Hemispheres Generously  
Manufactured Standard Woolen Domesticities  
HIGH GRADE MODERN FASHIONS WARRANTED FIRST CLASS**

CONDENSED ALDINE No. 150

72 POINT

4A 6a \$8 00

THOMAS Vanish

60 POINT

5A 7a \$7 00

Elated DRIVING 9

48 POINT

6A 10a \$6 30

DESIGN Matter Sent

36 POINT

10A 15a \$6 00

Wisdom THE FORFEIT 3

30 POINT

10A 15a \$4 00

FORBID Death Pomegranate

20 POINT

12A 16a \$4 00

PUNISHMENT OF OUR ANCESTORS

Ending Blissful Times \$980



CONDENSED ALDINE No. 150

18 POINT

18A 26a \$4 00

**RESULTS OF MAN'S FIRST DISOBEDIENCE**  
**Causing Banishment from Eden**

14 POINT

18A 26a \$3 75

**BIBLICAL ACCOUNT ABOUT WORLD CREATING**  
**Making the First Inhabitants 467**

12 POINT

22A 32a \$3 50

**BELIEVE NOT AMBITION WISE BECAUSE 'TIS BRAVE**  
**Soar Not High to Fall but Stoop to Rise**

11 POINT

24A 36a \$3 00

**MORTALS MUST SHARE THE FORTUNES OF THEIR TIMES**  
**And None but the Ancients Can be Always Classical 12**

10 POINT

24A 36a \$3 00

**SIN MAY BE CLASPED SO CLOSE WE CANNOT SEE ITS FACE**  
**Then Keep Each Passion Down However Dear 4680**

9 POINT

24A 36a \$2 90

**NUMEROUS INTERESTING DISCUSSIONS BY SCIENTIFIC GENTLEMEN**  
**Intellectual Pleasure Given to Attentive Listeners \$345**

8 POINT

26A 38a \$2 80

**SOFT AUTUMN BREEZES BLOW AND BEND THE RUSTLING GRASSES LOW**  
**The Melancholy Days Have Come, the Saddest of the Year**

7 POINT

36A 50a \$2 25

**TRANSATLANTIC PASSENGER BALLOON COMPANY'S DISTRIBUTION OF DIVIDENDS**  
**Stockholders Delighted with Flattering Prospects of Large Incomes 850**

6 POINT

30A 60a \$2 00

**PARADISE LOST, A POEM WRITTEN IN TEN BOOKS, BY JOHN MILTON, LICENSED**  
**Sold by Peter Parker, Under Creed Church, near Aldgate, London, 1667**

**CONDENSED TITLE No. 104**

28 POINT

14A 20a \$6 30

**Gathered During Autumn  
HAZEL NUTS**

22 POINT

14A 27a \$4 60

**Sparkling Electric Displays 54  
BRILLIANT SIGHTS**

18 POINT

18A 27a \$3 55

**Life Held Much Cheaper than Gold  
COLORADO MINERS**

12 POINT

25A 52a \$3 65

**78 Cheek of Adamant and also Nerves of Brass  
MOST HIGHLY ACCOMPLISHED**

10 POINT

36A 70a \$3 85

**Immense Rural Gatherings at the Harvest Homes  
ANNUAL COUNTRY FESTIVALS**

8 POINT

36A 70a \$3 25

**Teaches all the Latest Phases in Handkerchief Flirtation 36  
YOUNG LADIES BICYCLE ACADEMY**

6 POINT

36A 70a \$2 60

**234 Thousands Seek Pleasure but Very Few Find Everlasting Happiness  
PROGRESSIVE IN STYLES AND LUXURIES**

FULL FACE ITALIC No. 123

12

12 POINT

12A 24a \$2 65

*Furnishing Printing Specimens*  
**PROBATE NOTICES**

11 POINT

18A 36a \$3 30

*Metropolitan Prosperous Enterprise*  
**ROMANCE 64 PLEASING**

10 POINT

18A 36a \$3 20

*Northwestern Gigantic Warehouses*  
**BONANZA HARVEST**

9 POINT

18A 36a \$2 65

*Reasonable Estimates Furnished Printers*  
**947 ANCIENT MUSTY LEAVES**

8 POINT

18A 36a \$2 60

*Promenade Fashionable Brighton Resorts*  
**SECOND GRAND PRIZE 826**

6 POINT

24A 48a \$2 60

*Rambles Through Beautiful Adirondack Mountains*  
*During Autumn Months*  
**PISCATORIAL 354976 MONSTROSITIES**

5½ POINT

24A 48a \$2 65

*Wonderful Experience Adventurous Seamen Near Antartic*  
*Novelties Constantly Produced*  
**JEANETTE EXPEDITION HISTORY 6452**

FULL FACE No. 123

—12—

48 POINT

3A 6a \$9 20

**FAVored**

42 POINT

4A 8a \$6 80

**BEG 3 Cuts**

30 POINT

6A 12a \$5 80

**HUGE Carmel**

24 POINT

8A 16a \$4 70

**Lost Coats Found**  
**218 HOMES**

18 POINT

10A 20a \$4 25

**Cultivate Your Voice**  
**LUCKY DREAM**

14 POINT

12A 24a \$3 40

**Council Sustained Action**  
**CHRISTMAS 546**

FULL FACE No. 123

12

12 POINT

12A 24a \$2 60

**Christmas Treatment Overjoyed  
GRANDMA DARLING**

11 POINT

18A 36a \$2 95

**Strong Eastern Winds Subside Quick  
MARINE TROUBLE 123456**

10 POINT

18A 36a \$2 75

**Fortunate Speculation Unmanipulated  
AUTUMNAL ZEPHYRS**

9 POINT

18A 36a \$2 55

**Operators Declined Any Further Advances  
598 REJECT FOXY MAIDEN**

8 POINT

24A 48a \$3 25

**Married Women Quietly Combine Interests  
LEADING CITIZENS OBSERVANT**

7 POINT

24A 48a \$2 80

**Unscrupulous Demagogues Restoring Sinfulness  
EXPOSE SNEAK THIEVES 123456**

6 POINT

24A 48a \$2 55

**Patriotic Denizens Cheerfully Promulgate Principles  
Secreted During August  
UNPOPULAR SPECIALISTS RIDICULED**

5½ POINT

24A 48a \$2 75

**Stockholders Declare Quarterly Dividends Impracticable  
Providing Capital Inadequate  
12345 DEPRESSIVE COMPETITION 67890**

**ROMAN EXTENDED No. 120**

12

36 POINT

4A 8a \$8 75

Become

30 POINT

5A 10a \$5 85

MEN Born

24 POINT

6A 12a \$5 40

Drama Scene  
FOUND

18 POINT

8A 16a \$5 10

Bravest Heroes  
RUN 4 BIN

12 POINT

12A 24a \$3 70

Modern Silver Designs  
NEW YORK

**ROMAN EXTENDED No. 120**

12

10 POINT

12A 24a \$2 50

Present Constructions Modern  
Grandest Known  
**CURVED BORDER**

9 POINT

16A 32a \$2 75

Tremendous Wholesale Assignments  
54 Orange Groves  
**FRACTION CALAMITY**

8 POINT

18A 36a \$3 05

International Mounters Conventions  
Produced Continuous 4  
**NUMEROUS COMPOUND**

6 POINT

18A 36a \$2 30

Mechanical Arrangements Greatly Strengthened  
5 Prominent Maidens Tripping  
**HUNTING CALIFORNIA BEAUTIES**

5½ POINT

24A 48a \$3 05

Unmerciful Cannibal Devoured Indecorous Missionaries  
Commercial Industries 6  
**ELEGANT SUNSHINE FURNISHED**

5 POINT 24A 48a \$3 40

5 ON 6 POINT 24A 48a \$2 70

Fifteenth Anniversary Grand Complimentary Concert  
Frenchmen Select Convention  
**CLIMBING POSTHUMOUS DISTINCTION**

TITLE EXPANDED No. 120

12

48 POINT

3A 5a \$11 55

**BEau**

42 POINT

3A 5a \$8 60

**PICnic**

36 POINT

3A 6a \$5 60

**REDuce**

24 POINT

4A 8a \$4 15

**SIGN Here**

20 POINT

6A 12a \$4 35

**Rustic Scene 4  
BEARS**

18 POINT

6A 12a \$3 15

**Great Lakes Fresh  
HEXAGON**



**TITLE EXPANDED No. 120**

— 12 —

12 POINT

10A 20a \$2 80

**Latest Patriotic Message  
HIGHER PRICE**

10 POINT

12A 24a \$2 50

**Double Your Money Invested  
QUICK 456 RUNS**

9 POINT

18A 36a \$3 10

**Forcibly Exclude Dutiable Products  
Made Science Plain  
LIBERATED PRISONERS**

8 POINT

18A 36a \$3 10

**Boisterous Youths Become Insulting  
Electrical Engineering  
321 MEXICAN SAILOR 654**

6 POINT

18A 36a \$2 65

**Fortunate Proposals Handled Dubiously  
Columbian Museum  
COMMAND BAND BRIGADE**

5½ ON 6 POINT 24A 48a \$3 05

5½ POINT 24A 48a \$3 50

**Savages Wildly Sanction Diabolical Massacres  
Popular Kentucky Blue Grass  
UNKEPT MARBLE COLUMN 645**

IONIC SERIES

3-12-15

★48 POINT No. 30

4A 6a \$8 90

**2 SEcrets**

★42 POINT No. 159

4A 5a \$6 40

**MAIdens 5**

36 POINT No. 122

4A 8a \$5 20

**BIRD 4 Hums**

30 POINT No. 122

6A 12a \$4 90

**Darling Matrons  
WOMEN**

24 POINT No. 122

8A 16a \$4 70

**Hungry 95 Ancient  
NOTICEABLE**

IONIC SERIES

12

18 POINT NO. 122

10A 20a \$3 70

**Educational Information  
PERFECTIONS**

12 POINT NO. 122

16A 32a \$3 15

**Thirsty People Consider Hunger  
NUMBER 7485 SELECT**

10 POINT NO. 122

18A 36a \$2 60

**Magnificent Seminary Building Destroyed  
549 EUROPEAN SECURITY**

8 POINT NO. 122

24A 48a \$2 60

**Latest Reports Regarding European Steamers Received  
Special Document Returned 649  
SPRINGTIME RAMBLES THROUGH**

6 POINT NO. 122

24A 48a \$2 30

**Their Gallant Ship Skims Gracefully with Canvas Fluttering  
Constantly Exhibiting Furniture 936  
LAUGHABLE SITUATION UNAVOIDABLE**

5 POINT NO. 122

24A 48a \$2 60

**Disastrous Hailstorm Visited Philadelphia During Nineteenth Century  
Merchants Banking Association 8576  
HISTORICAL LITERATURE LATELY DISCOVERED**

**IONIC No. 150**

—15—

48 POINT

3A 5a \$7 00

**DIM HOE**  
**Presser**

42 POINT

5A 6a \$8 00

**GIVE MUSIC**  
**Produced**

36 POINT

6A 10a \$5 00

**FREE TRADING**  
**Continental**

24 POINT

7A 11a \$4 00

**EVENING HERALD**  
**Local Reporter**

**IONIC No. 150**

—15—

20 POINT

10A 16a \$3 50

**TYPOGRAPHIC MACHINE**  
**Superior Appliances 15**

12 POINT

17A 28a \$3 00

**EXHIBITS HANDSOME DESIGNS**  
**Charming Novelties**  
**Delighted Good Printers 50**

10 POINT

22A 32a \$2 75

**MOST USEFUL SERIES OF TYPE SHOWN**  
**Accurate and Durable Make**  
**Cast with Celebrated Copper Alloy 98**

8 POINT

24A 36a \$2 50

**COMBINED SPECIMEN BOOK OF THE BEST FACES**  
**Plain and Ornamental Jobbing Type**  
**Latest Products Furnished by Punch Cutters 45**

6 POINT

30A 45a \$2 25

**UNTO OTHERS DO EVEN AS YOU DESIRE THEM TO DO UNTO YOU**  
**Constant Adhering to the Golden Rule Advised**  
**Gentle People Exchanging Kindest Courtesies and Favors 73**

IONIC SERIES

48 POINT No. 122

3A 6a \$10 25

Dreams

42 POINT No. 122

3A 6a \$7 15

DECorate

36 POINT No. 120

6A 12a \$7 70

NOTE Horse

24 POINT No. 120

10A 20a \$5 65

ENGINE Recorder

18 POINT No. 120

16A 32a \$4 90

DISCOUNT 49 Numerous

12 POINT No. 120

18A 36a \$3 65

376 NEARING Broad Homes

10 POINT No. 120 18A 36a \$3 05

Beacons Eleventh  
AUCTION

8 POINT No. 120 24A 48a \$3 10

Submarine Telegraph  
DESTROYED

6 POINT No. 120 24A 48a \$2 50

Northeastern Metropolitan  
RAILROADS 54

5½ POINT No. 120 24A 48a \$2 55

African Continental Railroads  
87 CONSTRUCTED

ANTIQUE No. 127

24 POINT

8A 16a \$5 45

NEGRO Beaten

18 POINT

10A 20a \$3 90

BUNKER 4 Notorious

12 POINT

16A 32a \$2 95

Meritorious Recitations Honored  
TEACHERS ELATED

11 POINT

16A 32a \$2 45

Returns Indicate Unparalleled Victory  
256 FORTUNE CONTESTING

10 POINT

18A 36a \$2 70

Famished Boarders Conceal Thimbles  
INNOCUOUS DESUETUDE.

9 POINT

18A 36a \$2 05

Erroneous Calculations Averted Imminent Danger  
MONSTROSITIES INVIGORATED 836

8 POINT

24A 48a \$2 70

Performing Travelers Complacently Demonstrate  
1238 MONROE DOCTRINE CRITICISED

6 POINT

24A 48a \$2 30

Thousands Discussed European Intricacies Much Concerned  
MULTIPLIED INTERIOR DISORDERS 534

**CENTRAL ANTIQUE**

54 POINT

3A 5a \$10 00

Reason

48 POINT

3A 5a \$8 00

HOMES  
Found

42 POINT

4A 6a \$7 00

GROUND  
Breast

36 POINT

4A 6a \$5 00

EAST SIDE  
Purchase



CENTRAL ANTIQUE

15

30 POINT

5A 8a \$4 50

BURN MUCH  
Romancers

24 POINT

6A 10a \$4 00

ADMIRE'S BOOK  
Publish Notices

18 POINT

10A 16a \$3 25

STANDARD BRAND  
Delicious Cake

14 POINT

14A 20a \$3 00

REDUCTION IN WEIGHT  
Buy Seasonable Hats

12 POINT

18A 22a \$3 00

BIND SECURE  
Print Seven

10 POINT

22A 30a \$2 75

GOLDEN GOBLETS  
Latest Designs

8 POINT

24A 36a \$2 50

DANCERS CHARMED  
Graceful Movement

6 POINT

30A 42a \$2 25

FOUR ELECTION RETURNS  
Proclaim Great Victory

LINING ANTIQUE

---

36 POINT No. 40

6A \$4 50

MOTIONS

30 POINT No. 40

8A \$3 80

REFORMED

24 POINT No. 40

10A \$3 20

EXPERIMENT  
MEXICAN

18 POINT No. 40

14A \$2 55

BRIGHT SCHOLAR  
INDUSTRIOUS

12 POINT No. 40

25A \$2 25

TOURISTS IN MISFORTUNE  
CAUGHT TOGETHER

**LINING ANTIQUE**

4

10 POINT No. 40

30A \$2 00

**BOYS AND GIRLS RESTORATIVE  
GYMNASTIC EXERCISE**

8 POINT No. 40

36A \$2 00

**NOVEL ACROBATS AND BALL PLAYERS  
PITCHER AND TUMBLER**

6 POINT No. 45

45A \$1 90

**GATHERING OF THE MUTUAL ADMIRATION SOCIETY  
CONVOCAION OF CELEBRITIES**

6 POINT No. 44

45A \$1 60

**LIBERAL COMPENSATION ALLOWED FOR ADVERTISING SPACE  
BALD PATES WANTED IMMEDIATELY**

6 POINT No. 43

45A \$1 30

**RECOUNTING THE FIERCE STRUGGLES AND CONFLICTS OF BYGONE DAYS  
AGED VETERANS IN THE WARFARE OF LIFE**

6 POINT No. 42

45A \$1 15

**BUSY BRAINS AND ACTIVE FINGERS INVARIABLY PRODUCE DOMESTIC COMFORTS  
MECHANICAL GENIUS PROTECTED  
IMPROVED TOOLS AND INDUSTRIAL IMPLEMENTS**

6 POINT No. 41

45A \$1 10

**COUNTRY VISITS, COURTSHIP, MATRIMONIAL ALLIANCES AND ADVENT OF THE FIRST-BORN  
RED-LETTER DAYS IN MEMORY'S CALENDAR  
NOTEWORTHY OCCURRENCES AND IMPORTANT TRANSACTIONS**

1 2 3 4 5 6 7 8 9 0

ANTIQUE No. 124

11-12

★72 POINT

3A 4a \$14 15

**SEals**

48 POINT

3A 6a \$8 40

**ENTered**

42 POINT

4A 8a \$7 50

**RED Hairs**

36 POINT

5A 10a \$5 05

**5 PINE KNOTS**

30 POINT

6A 12a \$4 55

**Barn Martin Dead  
FARMER**

ANTIQUE No. 124

12

24 POINT

10A 20a \$4 80

**Bouncing 8 Managers  
IMPROVISED**

18 POINT

12A 24a \$4 00

**Monied Henchmen Donate  
BUILDER ERECT**

12 POINT

18A 36a \$3 40

**Beauties Received Coveted Rubies  
LENDING INTEREST 72**

10 POINT

18A 36a \$2 60

**Encountered Barbarian Stole Provisions  
HISTORIC PERSONIFICATION**

8 POINT

24A 48a \$2 90

**Nonentities Unanimously Disembodied Socialism  
PROTESTING LEADERS CONTEND 549**

6 POINT

24A 48a \$2 35

**Rushton Students Declare Their Behavior Invites Protest  
123 FAIR IMOGENE SUNK INTO OBLIVION**

5 ON 6 POINT

24A 48a \$1 85

**Presidential Communication Considered Unequivocally Patriotic Withal  
MONARCHIAL DOMINIONS DEVASTATED 12345**

ANTIQUE No. 125

—12—

42 POINT

4A 8a \$9 35

Montana

36 POINT

5A 10a \$7 90

DUE Hens

30 POINT

6A 12a \$5 80

NEW 4 Game

24 POINT

8A 16a \$4 70

97 BRING Marines

18 POINT

12A 24a \$4 45

Innumerable Mountains  
MERCHANDISE

12 POINT

18A 36a \$3 20

Northwestern Produce Merchandise  
NUMEROUS 35 MACHINES

**ANTIQUE No. 125**

12

10 POINT

24A 48a \$3 05

**Eastern Cartilaginous Fishes Transported  
Instrumental Selections  
SUBSTANTIAL SKYSCRAPERS**

9 POINT

24A 48a \$3 05

**Determined Mechanics Furnished Inhabitants  
44 Worlds Exposition Grounds  
HOUSEHOLD NOTIONS MORTGAGED**

8 POINT

24A 48a \$2 80

**Instantaneous Pictures Produced Entertainment  
Constitutional Amendment 46  
FURNISHED PRINTING SPECIMENS**

7 POINT

24A 48a \$2 25

**Established Remarkable Hospitable Educational Institutions  
Typographical Errors Eradicated 56  
ANCIENT TRADITIONS CLEARLY EXPOSED**

6 POINT

24A 48a \$2 30

**American Manufacturers Comprehend European Difficulties  
Characterized Excursionists Catastrophe 8  
SPONTANEOUS COMBUSTIONS PRINCIPALLY**

5½ POINT

32A 64a \$2 95

**Numerous Excellent Graduated Nutriments Thoroughly Confiscated  
Compositors Benevolent Amusement Association  
WILLING COMMENTATORS APPELLATIONS BESTOWED**

ANTIQUÉ No. 126

12

36 POINT

6A 12a \$6 00

**Printed Sermon**  
**MODERN**

24 POINT

10A 20a \$4 95

**French Music Teacher**  
**HARMONIC 234**

18 POINT

12A 24a \$3 60

**Grand Shaded Canvas Stands**  
**Renominated**  
**EXTEND THANKS**

12 POINT

16A 32a \$2 50

**Procuring Instructive Medical Authority**  
**International Exhibition**  
**2468 MUSIC HATH CHARMS**



**ANTIQUÉ No. 126**

11 POINT

16A 32a \$2 20

**Celebrated Historical Teacher Resumes Study  
ENLARGE STEREOTYPING OUTFITS**

10 POINT

18A 36a \$2 35

**Thoroughly Represented Diplomatic Statesmen  
Behold Degenerate Emperor  
KINDHEARTED 32 SAMARITANS**

9 POINT

18A 36a \$2 10

**Counterfeit Unscrupulous Methods Prove Unavailing  
Courteous Councilmen Imprisoned  
SCIENTIFIC BOTANICAL DEPARTMENT**

8 POINT

20A 40a \$2 25

**Marked Interesting Quotations Throughout Lectures  
Subjects Receive Attention  
DISPLAY WONDERFUL VITALITY 12**

6 POINT

24A 48a \$2 15

**Proper Officials Should Zealously Guard Contagious Locality  
Backcapping Fossilized Political Scheme  
REINVIGORATE DEPOPULATED MUNICIPALITIES**

5½ POINT

24A 48a \$2 00

**Wisecracs Artfully Overcame Unfriendly Feeling Between Foreign Nationalities  
Melodious Voices Singing Requiems Over Departed Friends  
6172839 HEARTRENDING APPEAL FROM VENEZUELAN PATRIOT**

SKELETON ANTIQUE No. 122

12

60 POINT

6A \$4 70

RINGS GOLDEN

48 POINT

6A \$4 45

HORSE 4 LOANS

36 POINT

8A \$3 30

56 CLEVER MONKEYS

24 POINT

12A \$2 85

NUMBER BRANCH HOUSES 78

18 POINT

16A \$2 20

BRAVE FIREMEN 648 SAVING CHILDREN

12 POINT

24A \$2 10

547 HANDSOME WEDDING PRESENTS EXPENSIVE

10 POINT

24A \$1 55

BRIGHTEST HOPES IMAGINED ARE THE MOST FLEETING 9853

8 POINT

36A \$2 00

876543 BE THOU CHASTE AS SNOW THOU SHALT NOT ESCAPE CALUMNY

ANTIQUÉ CONDENSED

12-15

36 POINT NO. 152

6A 10a \$5 00

IMPORT Brands

30 POINT NO. 152

8A 12a \$4 50

PICTURES Moonlit

24 POINT NO. 152

10A 14a \$4 00

WRINKLES Literature

20 POINT NO. 152

12A 16a \$3 50

NEW LEDGER ACCOUNT  
Debits are Entered 26

18 POINT NO. 122

12A 24a \$3 50

COLLECTION OF SPECIMENS  
Army Maneuvering Corps

12 POINT NO. 122 18A 36a \$2 85

ROUGH DIAMOND  
83 Uncut Gems

10 POINT NO. 122 24A 48a \$2 85

BUSINESS CHANCES  
New Spring Styles

8 POINT NO. 122 24A 48a \$2 35

HEALTHFUL EXERCISES  
Running and Jumping

6 POINT NO. 122 24A 48a \$1 90

NIGHT SCHOOL REMEMBERED  
Admirable Description

ANTIQUE CONDENSED

72 POINT No. 122

3A 5a \$10 00

MOUNTAINS

60 POINT No. 122

3A 6a \$7 25

FORM GRACES

48 POINT No. 122

4A 8a \$5 50

HUMAN NATURES  
MARKETING

36 POINT No. 122

6A 12a \$5 45

EDUCATED SENATORS  
ENCLOSING

**ANTIQUE CONDENSED**

—11-12—

30 POINT NO. 122

8A 16a \$4 65

**Numerous Specialties**  
**EDUCATIONAL**

24 POINT NO. 122

10A 20a \$3 65

**Bronze Pictures Handsome**  
**MUSICAL FRIENDS**

18 POINT NO. 116

15A 24a \$2 90

**Summer Wisconsin Excursion 46**  
**BEAUTIFUL LAKES**

14 POINT NO. 116

16A 30a \$2 85

**892 Evening Chat with Cheerful Friend**  
**WONDERFUL ADVENTURE**

12 POINT NO. 116

20A 30a \$2 55

**Kind Words When Sincerely Welcome 567**  
**LAY AWAY GLOOMY DESPAIR**

10 POINT NO. 116

24A 50a \$2 70

**34 Delightful Tale of Robinson Crusoe the Romantic**  
**YOUTHFUL DREAM OF PARADISE**

ANTIQUE EXTRA COND. No. 150

12-15

★96 POINT

3A 4a \$10 85

USE 3 Brick

72 POINT

3A 5a \$8 50

MAKE Havoc 5

60 POINT

4A 6a \$6 50

FOREIGN 4 Trader

48 POINT

4A 7a \$5 00

SOCIAL Intercourse 8

ANTIQUE EXTRA COND. No. 150

15

42 POINT

5A 8a \$4 50

SOUND the loud timbrel 2

36 POINT

7A 11a \$4 25

THE DARK 45 Plutonian Shore

30 POINT

9A 12a \$4 00

PARISIAN Clothing Display 32

24 POINT

11A 17a \$3 75

HE THAT REVENGES 23 knows no rest

20 POINT

10A 16a \$3 50

SPRING FLOWERS 5 Brighten the Universe

18 POINT

14A 20a \$3 25

THE ONLY ROSE 4 without Thorns, Friendship

12 POINT

16A 26a \$3 00

Husbandmen Reaping and Harvesting Grain and Fruit 73  
AUTUMNAL GATHERING GARNERED

10 POINT

20A 32a \$2 75

Friends drop in and remind you  
WE HAVE DEBTS TO PAY

8 POINT

22A 32a \$2 50

And Anger Brings Forth Hard Blows  
WORDS STIR UP ANGER

ANTIQUE CONDENSED No. 123

60 POINT

3A 6a \$6 55

**BRICK Homes**

48 POINT

4A 8a \$5 75

**ROME 8 Demon**

42 POINT

6A 12a \$5 55

**MENDING Fortunes**

30 POINT

8A 16a \$4 40

**EMPHATIC 36 Damsels**

24 POINT

12A 24a \$4 20

**Defective Fences Remedied**  
**SOLDIERS FOUGHT**



ANTIQUE CONDENSED No. 123

18 POINT

12A 24a \$3 05

**DISCOURAGING Reports Prevailed**

16 POINT

12A 24a \$2 40

**Painters Develop Grand Artistic Effects  
MODERN PRINTER REFINED**

14 POINT

16A 32a \$2 70

**Locomotor Ataxia Conveying Rheumatism  
SUBLIME ORGANIC MOTIVES 52**

12 POINT

18A 36a \$2 30

**Representatives Straightway Accomplish Notations  
NORTHUMBERLAND 58 DISMANTLING**

10 POINT

24A 48a \$2 30

**Extraordinary Courage Displayed Throughout Many Battles  
Herculean Efforts Accomplished Result  
MONGOLIANS DISPLAY WONDERFUL MEMORIES**

8 POINT

24A 48a \$2 15

**Odorless Benzine Produced Without Technical Experiments  
Excessive Freight Charges Rebated  
WORTHY BOHEMIAN MAIDENS HAPPY 1234**

ANTIQUE CONDENSED No. 124

4-12

★72 POINT

5A \$8 35

**MINUETS**

60 POINT

4A \$4 20

**MORE PUNS**

48 POINT

5A \$3 40

**OCEAN SHORE**

42 POINT

6A \$3 00

**DESK 53 OPENS**

36 POINT

8A \$2 55

**HUMBUGS RESPOND**

ANTIQUE CONDENSED No. 124

24 POINT

12A \$2 40

**FOUGHT DARK NIGHTS**

18 POINT

16A \$2 30

**EXCHANGE RARE PRESENTS**

16 POINT

18A \$1 75

**POLICE CAPTURE BOLD BANDITS  
AFTER LIVELY CHASING**

14 POINT

18A \$1 40

**UNIFORM BANKING HOURS OPTIONAL  
WATCH 1234 TRAMPS**

12 POINT

24A \$1 45

**GENERALS COMPARE MODERN WARFARE  
EMPEROR DEPOSED TRAITOR**

10 POINT

24A \$1 25

**NOTORIETY EASILY GAINED AMONG FISHERMEN  
5678 DURING TROLLING SEASON**

8 POINT

24A \$1 00

**REMUNERATIVE POSITION GENEROUSLY BESTOWED UPON  
BENEVOLENTLY DISPOSED KENTUCKIAN 1234**

**BRETON SERIES**

48 POINT

3A 3a \$8 00

**Lone 2  
HOUR**

40 POINT

3A 4a \$5 00

**Termed 8  
MINERS**

24 POINT

7A 10a \$4 00

**Desert 67 Homes  
Sandy Plains  
QUITE BRIGHT**

BRETON SERIES

18 POINT

12A 18a \$3 25

**Washington 90 Marches  
Silent at Eventide  
VICTORY RESULTED**

12 POINT

16A 24a \$3 00

**Clever 357 Decampment of Troops  
Christmas and Fireside  
FROSTY CAMPS AHEAD**

10 POINT

20A 30a \$2 75

**Soldiers Encounter 412 Numerous Hardships  
Experienced Terrible Hindrances  
RUSHING DELAWARE WATERS**

8 POINT

24A 36a \$2 50

**Green Graves and 137 Mossy Hillside for Monuments  
Sweet Dreams Visit Those Patriotic  
COURAGEOUS HEROES SLUMBERING**

6 POINT

28A 42a \$2 25

**Peace and Contentment Reign Throughout the Country \$432  
Prosperity the Outcome of Cruel Warfare  
GLORY FOREVER FOR THE UNITED STATES**

**CLARENDON No. 120**

— 12 —

48 POINT

4A 8a \$8 30

**MEN Hate**

36 POINT

5A 10a \$6 40

**SOUR 4 Cider**

30 POINT

6A 12a \$4 15

**Handsome Railroads  
DISASTROUS**

24 POINT

8A 16a \$3 35

**Harmonious 7 Instrument  
POLICE COURT**

18 POINT

10A 20a \$2 95

**National Yellowstone Park 8  
MODERN STORIES**

CLARENDON No. 120

—12—

12 POINT

16A 32a \$2 95

**Substituted Chocolate Decoctions**  
**AMERICAN GIRLHOOD**

11 POINT

16A 32a \$2 40

**394 Mohammedan Adventurers Befriended**  
**GOVERNMENT EXAMINATION**

10 POINT

18A 36a \$2 50

**Indestructible Microscopical Inventions 42**  
**HANDSOME GENTLEMEN**

9 POINT

18A 36a \$2 00

**685 Commander Neversweats Dangerous Predicaments**  
**Participants Severely Reprimanded**  
**PERSEVERANCE OVERCAME DIFFICULTIES**

8 POINT

24A 48a \$2 50

**University Graduates Terrorizing Neighborhoods 768**  
**Diminutive Brownies Excursions**  
**INTERNATIONAL DEMONSTRATIONS**

6 POINT

24A 48a \$2 05

**Renowned Kentuckian Thoroughbred Trotting Stallion Beaten 38**  
**Distinguished Congressmen Debating**  
**MISCELLANEOUS SENATORIAL CONTEMPLATIONS**

CLARENDON CONDENSED No. 122

12

60 POINT

3A 6a \$6 05

SINFUL Printer

48 POINT

4A 8a \$5 10

BONDS 42 Recover

36 POINT

6A 12a \$3 85

LENDING Furniture 26

24 POINT

8A 16a \$2 95

32 PROCURING Contributions

18 POINT

12A 24a \$2 45

Numerous Failures Reduced Manufacturer  
PATRIOTS RESCUED IRISHMEN



CLARENDON CONDENSED

1-12

60 POINT NO. 10

3A 4a \$9 68

BIG head

48 POINT NO. 120

4A 8a \$7 60

4A \$2 80

NOBLE Girls

42 POINT NO. 120

5A 10a \$6 55

5A \$2 35

RED FOR Him 4

36 POINT NO. 120

6A 12a \$5 45

6A \$2 00

25 BIRD MEN Sold

30 POINT NO. 120

8A 16a \$4 65

8A \$1 60

ENDS MANY Songs 86

24 PT. 120 10A 20a \$3 60 10A \$1 30

Grand DRINK

18 PT. 120 12A 24a \$3 00 12A \$1 00

MEN FOR TOWN

12 PT. 120 16A 32a \$2 35 16A \$0 75

Yearnings Prevailed  
TEARS BOILED

10 PT. 120 18A 36a \$2 00 18A \$0 70

Evasive Tablet Removed  
STRICT ORDERING

ANTIQUE EXTENDED No. 122

---

30 POINT

4A 8a \$6 45

**DISarm**

24 POINT

5A 10a \$5 05

**ENDures 4**

12 POINT

8A 16a \$4 00

**Moved Frame  
BRAND**

10 POINT

10A 20a \$3 70

**Printer 5 Broken  
EMPORIUM**

---

ANTIQUE EXTENDED No. 123

---

12 POINT

16A \$2 35

**LIQUIDS TESTED**

10 POINT

18A \$2 05

**BROKER 49 RESIGN**

8 POINT

24A \$2 25

**36 MEN IN CONFIDENCE**

6 POINT

24A \$1 90

**RETURNING 345 MERCHANT**

5 POINT

24A \$1 65

**ENGINES RUSHING DOWN GRADES 12345**

ANTIQUE EXTENDED No. 152

15

36 POINT

5A \$7 00

**BEST**

30 POINT

5A \$5 00

**ARMED**

24 POINT

6A \$3 00

**SERMON**

20 POINT

8A \$2 75

**MORNING**

18 POINT

10A \$2 60

**MEMORIAL 6**

12 POINT

15A \$2 25

**TORPEDO BOATS**

---

ANTIQUE EXTENDED No. 153

15

24 POINT

4A 6a \$3 35

**HER Love**

ANTIQUE EXTENDED No. 120

12

24 POINT

4A 8a \$5 75

**Recover  
DINE**

18 POINT

6A 12a \$5 25

**Hard Lines  
MEND 4**

12 POINT

8A 16a \$3 95

**Lemon Grove  
6 NUTMEG**

10 POINT

12A 24a \$3 95

**Debator Ridiculed  
SPURING 24**

8 POINT

12A 24a \$3 20

**Formalities Enlivened  
57 RESENTMENT**

6 POINT

12A 24a \$2 50

**Numerous Colonies Threaten  
REFUTING EVIDENCE**

5 POINT

18A 36a \$3 50

**Maine Statesman Recommends Measures  
BRITISH ENRICHMENT 7 2 3**

ANTIQUE EXTENDED No. 124

12

42 POINT

3A 6a \$10 40

**Extra**

30 POINT

4A 8a \$6 40

**PRInter**

24 POINT

6A 12a \$5 45

**SITUation 4**

18 POINT

8A 16a \$4 45

**FINE 9 Silver**

12 POINT

10A 20a \$3 65

**LEGAL Tender 8**

10 POINT

10A 20a \$2 75

**MODEST 4 Festivities**

8 POINT

16A 32a \$3 30

**Beauties Treasures Supreme  
ARTFUL DECEIT**

6 POINT

18A 36a \$2 90

**3 Midwinter Excursions Southwest  
DELIGHTFUL RECREATION**

**French Clarendon Extended No. 120**

—12—

42 POINT

3A 5a \$8 85

**BRoke**

36 POINT

3A 6a \$6 00

**STIEams**

30 POINT

4A 8a \$4 95

**Monstrous  
HORDE**

24 POINT

6A 12a \$5 05

**Names Rome  
FORM 52**

18 POINT

8A 16a \$4 70

**Proposed Theatre  
NATIONAL**

**French Clarendon Extended No. 120**

12

12 POINT

10A 20a \$3 45

**Famous Engraving  
PURCHASED**

11 POINT

12A 24a \$3 50

**Thankless Organization  
MUSICAL 48**

10 POINT

16A 32a \$3 45

**Nowhere Boastful Interested  
GLORIOUS MEDIUMS**

8 POINT

18A 36a \$3 20

**Experiences Practically Established  
Create Confidence Great  
HUMANITY BALANCING**

6 POINT

18A 36a \$2 30

**Statement Commercially Introduced Sustained  
National Government Treasury  
CONFIDENCE NOW PERMANENT**

5 POINT

20A 40a \$2 85

**Theories Expressed Lucidly Encouraged Phenominal  
Energetic Mechanical Engineers  
MODERN TEDIOUS DUTIES INDORSED**

EGYPTIAN EXTENDED

-2-3

48 POINT NO. 20

3A 4a \$7 50

**Beaten 9**

36 POINT NO. 20

4A 6a \$5 50

**LUCA Salts**

24 POINT NO. 20

6A 10a \$4 25

**Indian SOIREE**

18 POINT NO. 20

10A 15a \$3 50

**FRAMOSE 2 Tecoma**

12 POINT NO. 20

14A 20a \$3 00

**Confiscated 284 Regiments  
EUROPEAN KINGDOMS**

10 POINT NO. 30

20A 30a \$2 60

**Transoceanic 26 Communicator  
RAILROAD EXCHANGE**

8 POINT NO. 30

20A 30a \$2 60

**Curative Qualities 27 American Resorts  
MINERAL WATER SPRINGS**



FRENCH ANTIQUE No. 110

48 POINT

3A 4a \$8 25

**TOM Cat**

42 POINT

4A 5a \$8 20

**BIG Saw 5**

36 POINT

4A 6a \$5 60

**3 FINE Rain**

30 POINT

6A 8a \$4 60

**GOLD Bracelet 5**

20 POINT

10A 16a \$3 00

**Pleasures 2**  
**MORAL**

12 POINT

20A 38a \$3 25

**Their Fruits and**  
**TREES**

8 POINT

30A 60a \$2 70

**Bivouac and Battle 567**  
**REVOLUTION**

18 POINT

10A 16a \$2 75

**Grandfather 5**  
**TENUP**

10 POINT

20A 38a \$2 50

**Now Fast Asleep 89**  
**LITTLE BEE**

6 POINT

30A 60a \$2 60

**Factors in Modern Progress**  
**PRINTING PRESSES**

**FRENCH CLARENDON No. 120**

—12—

72 POINT

3A 5a \$14 15

**END** Dears

60 POINT

3A 6a \$8 50

**BIG** Pad 2

48 POINT

4A 8a \$6 80

**TURN** Brains

36 POINT

6A 12a \$6 50

**8 FIRST** Match

30 POINT

8A 16a \$4 65

**PERFECT** Counterfeits

**FRENCH CLARENDON No. 120**

12

24 POINT

12A 24a \$4 55

**Handsome Gifts Distributed  
BRIGHT SCENES**

18 POINT

12A 24a \$3 00

**Practical Business Methods Restored  
DESERVED COURTESY 25**

12 POINT

18A 36a \$2 90

**Patrons Select Various Christmas Gifts  
68 COMPLETE SERIES**

10 POINT

24A 48a \$2 65

**Composing Distasteful Sentences Easily Prevented  
CURIOSITIES FROM INLAND COUNTRY**

8 POINT

24A 48a \$2 30

**Overstocked Warehouses Collapse Entailing Frightful Losses  
CUSTOMARY DELEGATES RESPOND 12345**

6 POINT

32A 64a \$2 10

**Frivolous Young Maidens Ingeniously Escape From Their Seminary Boarding Houses  
Handsome Typographical Effects Intelligently Depicted  
VANDALS RETIRE WITHOUT DESTROYING BEAUTIFUL MONSTER**

**Egyptian Extra Condensed No. 120**

72 POINT

3A 6a \$8 70

**MODEST Dream**

60 POINT

4A 8a \$7 40

**Detective Recovers**

**EUROPEAN 7**

48 POINT

4A 8a \$5 20

**Home Commercial Nerve**

**BENDING NORTH**

**Egyptian Extra Condensed No. 120**

12

42 POINT

8A 16a \$7 05

**COMPOSITION Manufacturers**

36 POINT

8A 16a \$5 25

**Mexican Consumers Extreme Measures  
CHICAGOS 4 HUNDRED**

24 POINT

12A 24a \$4 30

**Americas Lonesome Fisherman Controls Minnows  
ELEGANT DRAWINGS PUBLISHED 56**

18 POINT

12A 24a \$2 80

**Aristocratic Californians Incubate Horizontal Hailstorms 23  
HUMOROUS MUSCULAR DIFFICULTY**

12 POINT

16A 32a \$2 60

**Switzerland Mountain Excursionists Witnessed Beautiful Fountains  
38 NEWSPAPER PROPRIETORS ASSOCIATION**

NEW TUSCAN No. 120

12

48 POINT

4A 8a \$8 50

**DOG Runs**

42 POINT

5A 10a \$6 80

**NICE 4 Time**

36 POINT

6A 12a \$6 05

**ROMAN Faces**

24 POINT

8A 16a \$4 00

**Hungarian Emporium**

**75 DESIRABLE**

18 POINT

10A 20a \$3 50

**Mineral Spring Water Fame**

**FRESCO PAINTER**

ANTIQUÉ POINTÉ No. 120

—12—

48 POINT

3A 5a \$9 65

**Dances**

42 POINT

3A 6a \$7 45

**MODern**

36 POINT

4A 8a \$6 70

**DElicate 7**

30 POINT

5A 10a \$4 50

**FINE 4 Toned**

24 POINT

6A 12a \$3 90

**69 PINK Noses**

18 POINT

8A 16a \$3 85

**MENU 65 Medals**

12 POINT

10A 20a \$2 55

**BRIGHT June Flowers 4**

DORIC No. 120

—12—

48 POINT

3A 6a \$9 00

**REStore**

42 POINT

3A 6a \$6 90

**MUD Pies**

36 POINT

4A 8a \$6 40

**HER 4 Love**

30 POINT

4A 8a \$5 40

**France Burns  
RIOTER**

24 POINT

8A 16a \$5 50

**Princes Deserve  
TRUTH 25½**



DORIC No. 120

12

18 POINT

10A 20a \$5 20

**Reliable Theatres  
GROW RICH**

12 POINT

12A 24a \$2 90

**Blended Harmonious Colors  
DELIGHT 4 SCORES**

10 POINT

16A 32a \$2 95

**Leaders Denouncing Paternalism  
58¼ DISTANT REGION**

8 POINT

20A 40a \$3 10

**Previous Manifestations Encountered  
RETURNS PRESENT 642½**

7 POINT

24A 48a \$2 75

**Memorable Festivities Characterized Germanians  
437½ HUNDREDS DELIGHTED**

6 POINT

24A 48a \$2 55

**Notorious Statesman Discusses Imminent Disturbances  
Recommends forcible Measures  
ENGLISH SOVEREIGN DEMONETIZED 364¼**

5 ON 6 POINT

24A 48a \$2 55

**Fostered Industries Evincing Undesirable Inclinations  
Multitudes Protest Vociferously  
IMPOSITION FINDS RESENTMENT 12345**

LATIN CONDENSED No. 150

72 POINT

4A 6a \$8 50

LATER Show

60 POINT

5A 6a \$7 50

HORIZON ROOMS

48 POINT

4A 7a \$5 00

ELEGANT HOMES  
Settlements

36 POINT

8A 12a \$4 25

PICTURESQUE WOODS  
Representations 68

LATIN CONDENSED No. 150

30 POINT

10A 15a \$4 00

IMPROVEMENTS DESIRED

Interests Printers 25

24 POINT

15A 20a \$3 75

TRANSCENDENTAL KNOWLEDGE

Speculative Philosophy

18 POINT

20A 30a \$3 25

ENTERTAINMENT FOR HILARIOUS MORTALS

Pleasurable Incident Minutely Related

12 POINT

28A 38a \$3 00

AMUSEMENTS OF NINETEENTH CENTURY CIVILIZATION

Lawn Tennis, Base Ball, Rowing and Running

10 POINT

36A 50a \$2 75

CONSCIENTIOUS LEGISLATORS CLASSED AS GREAT CURIOSITIES

Rare Specimens Collected and Placed in Museums

MODERN ANTIQUE

11

72 POINT

3A 4a \$11 20

Brent 1

60 POINT

4A 5a \$10 25

GUILTY

Dean 4

48 POINT

5A 8a \$10 90

TRIUMPH

Steam 16

MODERN ANTIQUE

42 POINT

6A 10a \$8 90

**HARD COAL**  
**Weighed**

36 POINT

8A 12a \$8 50

**GRAND FEAST**  
**Barbecue 8**

30 POINT

10A 16a \$6 40

**BRAIN PORTIONS**  
**Anatomical 4**

20 POINT

12A 20 \$4 50

**POWERFUL NORMANS**  
**Daring Pioneers**

**MODERN ANTIQUE**

18 POINT

16A 24a \$3 90

**PICTURES FROM CHILDHOOD**  
**Doth Make Love Slowly**

12 POINT

20 A 40a \$3 00

**NUMEROUS MODERN IMPROVEMENTS**  
**Excellent Style and Finish**  
**Is Useful as Well as Ornamental**

10 POINT

24A 50a \$3 00

**SOUNDING OF DISCORDS IN CHURCH CHORUS**  
**Singing the Poorest Hymns 25**  
**Eighteen Hundred and Ninety-four 1894**

8 POINT

30A 60a \$3 00

**LANGUID CROQUET AND TENNIS CLUB MEMBERS**  
**Desirable Enthusiasm Lacking**  
**Partners and Opponents are Disgusted 34**

6 POINT

30A 60a \$2 50

**TEACHER AND APOSTLE OF OCCULT SCIENCES SUPPORTED**  
**Grandest Promises to Investigators**  
**Insisting on Most Unendurable Abstemiousness 90**

MODERN ANTIQUE WIDE No. 110

48 POINT

3A 4a \$8 90

**BE Just**

36 POINT

4A 6a \$7 00

**Colds DIP**

30 POINT

6A 8a \$5 60

**LIVE DUCK  
Sportsmen**

20 POINT

10A 16a \$4 85

**SAME MANNER  
Condemn Piano**

18 POINT

10A 16a \$3 75

**PUBLISHED FICTION  
Strangest Stories**

12 POINT

20A 30a \$3 65

**HAPPY CHILDHOOD DAYS  
Useful Man Friday \$40**

LATIN EXTENDED

— 15 —

36 POINT

3A 4a \$8 65

**Royal**

30 POINT

4A 6a \$6 90

**France**

24 POINT

6A 8a \$6 95

**HIT Bag**

18 POINT

8A 12a \$5 60

**SEA Dogs**

14 POINT

10A 14a \$4 95

**CAKE Bakers**

12 POINT

12A 20a \$3 40

**COMING Attraction 4**

10 POINT

18A 24a \$3 60

**DEPARTURE and Arrival**

8 POINT

24A 32a \$3 75

**CONTENTMENT very Desirable**

6 POINT

30A 40a \$3 90

**BEAUTIFUL SNOW Storms Arrived**



HARDWARE SERIES

12

36 POINT

3A \$5 50

**BUM**

24 POINT

6A \$4 15

**HORSE  
HIDE**

18 POINT

6A \$2 45

**REMINDS  
SURE**

12 POINT

10A \$2 10

**ENCOURAGE  
HOPES**

10 POINT

10A \$1 55

**HOMES DIRECT  
MAIDENS**

ALL SIZES IN THIS SERIES LINE AT THE BOTTOM.

BROADGAUGE

40 POINT

5A \$10 70

**CONE**

36 POINT

5A \$8 85

**DINES**

28 POINT

5A \$6 10

**SHINED**

22 POINT

7A \$4 65

**RED INKS**

18 POINT

10A \$5 05

**BOND GRAB**

12 POINT

14A \$4 20

**ROUND NUMBER**

10 POINT

18A \$4 05

**GRECIAN IRONCLAD**

8 POINT

22A \$3 80

**UNIQUE BORDER DESIGN**

6 POINT

25A \$3 40

**SCIENTIFIC MEDICAL QUALITIES**  
**1 2 3 4 5 6 7 8 9 0**

**CONCAVE EXTENDED No. 120**

—12—

48 POINT

3A 6a \$11 50

**Races**

36 POINT

4A 8a \$8 55

**MINeral**

24 POINT

6A 12a \$5 75

**FINE Horse**

18 POINT

8A 16a \$4 55

**MARKS Former**

12 POINT

12A 24a \$3 25

**HYMNALS Harmonized**

9 POINT

12A 24a \$2 35

**Race Gigantic Ocean Steamers  
HUMANITARIAN 243**

6 POINT

18A 36a \$2 25

**Beautiful Golden Designs Accurately Measured  
2345 MISERABLE COMPOSITION**

**CONCAVE No. 120**

—12—

36 POINT

4A \$3 80

**RECORD**

30 POINT

6A \$3 50

**BENCH 45**

28 POINT

8A \$3 55

**HARE DOGS**

24 POINT

10A \$3 30

**REMUNERATE  
DIVIDEND**

20 POINT

12A \$2 95

**BRANCH HOUSE  
HENCE 945**

**CONCAVE No. 120**

—12—

18 POINT

18A \$2 65

**BRIGHTLY SHINING  
POLAR LIGHTS**

12 POINT

18A \$1 85

**MOST TRUTHFUL HISTORY  
ARTISTIC PRINTER**

10 POINT

24A \$1 50

**SUPERB FAMILY BOARDING HOUSES  
HANDSOME ARTICLES  
ARTISTIC FLORAL PIECES 6459**

8 POINT

24A \$1 25

**THEY STOLE THE CARDINALS DIAMOND RING  
WALL STREET BROKERS  
FEARFUL CONSTERNATION AMONG**

6 POINT

32A \$1 35

**BOSTONS GLORIOUS MUSEUMS ANCIENT IMPLEMENTS  
VARIOUS DANGEROUS WEAPONS  
AROUND THE POSTS HUNG HELMETS 94573**

**CONCAVE CONDENSED No. 120**

—12—

72 POINT

4A \$6 55

**NOTIONS**

60 POINT

5A \$5 60

**HUM CLUB**

48 POINT

6A \$4 80

**MEAN HOUR**

42 POINT

8A \$3 85

**NOBLE HORSES**

ALL SIZES LINE AT THE BOTTOM.

CONCAVE CONDENSED No. 120

36 POINT

10A \$3 10

RUSTING CLOTHES

24 POINT

16A \$2 90

BARGAINED HANDSOME

20 POINT

18A \$2 50

LIBERTYS MARBLE STATUES  
UNITED 549 BRANDS

16 POINT

24A \$2 15

RELIABLE DOMESTICS FURNISHED  
786 VERY DISTANT MOUNTAIN

12 POINT

24A \$1 20

MAGNIFICENT PICTURES RECENTLY PAINTED  
DISCOVERED 379 TORTOISES  
INTRODUCING GORGEOUS COSTUMES

**RUNIC CONDENSED No. 120**

72 POINT

3A 5a \$12 85

BOS<sup>t</sup>on

60 POINT

3A 5a \$8 25

HER Fate

48 POINT

3A 6a \$6 10

RUGS Laid 6

42 POINT

4A 8a \$4 60

28 MICE Return

30 POINT

5A 10a \$3 40

LEMON 42 Relieves



---

**RUNIC CONDENSED No. 120**

—12—

24 POINT

6A 12a \$2 80

Eleven Known Miseries  
MINTS 4 CLOSE

18 POINT

8A 16a \$2 60

Frustrate Criminal Schemes  
24 PUNGENT HEROISM

14 POINT

10A 20a \$2 05

Miseries Burden Armenian Peasant  
NATIONS CONSULTING 87

12 POINT

12A 24a \$1 80

Liberal Bachelors Endowed Gentle Maidens  
35 FOREIGN NOBLES DELIGHTED

10 POINT

18A 36a \$1 95

Reserved Matrons Criticised Bloomerfield Advocates  
Meritorious Features Demonstrated  
PEDESTRIANS UNSPEAKABLY SHOCKED 63

**RUNIC CONDENSED No. 122**

— 12 —

60 POINT

4A \$8 55

NOBLE

48 POINT

4A \$4 05

HONEY 4

42 POINT

6A \$4 05

ROMANCER

36 POINT

8A \$3 15

HORSE RACES  
5 EMOTION

**RUNIC CONDENSED No. 122**

—12—

24 POINT

10A \$2 40

GENUINE ORANGE

20 POINT

12A \$2 10

BREAKING MACHINES  
LONG 495 STAR

16 POINT

16A \$1 75

MORTAL ENEMIES ENTERED  
IMAGINARY JEALOUSY

12 POINT

18A \$1 35

NEVER EXPECT MORE GOLD THAN  
WHAT YOU ORDERED 947

10 POINT

24A \$1 30

MERRY AUTUMN INTRUDES UPON SUMMER  
DREAMS PROVING SERIOUS

8 POINT

32A \$1 40

FAMOUS EXHIBITS BROUGHT SUFFICIENT REWARDS  
675 DREADFUL WINDSTORMS PREDICTED

LIGHT RUNIC

11-15

48 POINT NO. 110

4A 6a \$9 35

GUN Shot

42 POINT NO. 152

5A 8a \$7 25

HOPE Stars

36 POINT NO. 110

5A 8a \$6 85

FAIRY Tales

30 POINT NO. 152

8A 12a \$5 95

MODERN Maids

24 POINT NO. 152

10A 16a \$4 55

DOMESTIC Changes

18 POINT NO. 152 12A 18a \$3 30

Ladies Invest

14 POINT NO. 152 14A 20a \$2 40

Illustrated Poem

12 POINT NO. 152 20A 40a \$2 80

Moonlight on the Beach

10 POINT NO. 152 18A 36a \$2 00

Franklin County Members

ENTERTAINING

ANNUAL MEETING

LATIN No. 20

36 POINT

6A 8a \$4 50

FRENCH BONDS  
Money 26 Issued

28 POINT

8A 10a \$4 00

QUAKER PROMISE  
Devoted 45 Friends

22 POINT

10A 14a \$3 50

HARTFORD MACHINES  
Romantic and Beautiful 8

18 POINT

14A 20a \$3 25

DESIRING CHAMBER TABLES  
Second Flight 197 Grand Hotel

LIGHTFACE CELTIC No. 150

15

48 POINT

3A 4a \$8 50

SOUND  
Horse

36 POINT

4A 6a \$6 25

GERMAN  
Dancing

30 POINT

5A 7a \$5 00

BEST MADE  
Ornament

24 POINT

7A 10a \$3 50

OLD UNIFORMS  
Save Coats

**LIGHTFACE CELTIC No. 150**

—15—

18 POINT

10A 16a \$3 25

**QUIETNESS REIGNS**  
**Strife Finished**

12 POINT

16A 26a \$3 00

**GUN AND CANNON AT REST**  
**Deaths Messengers**  
**Rusty Weapons Found 98**

10 POINT

18A 28a \$2 75

**DEPARTED HEROES FORGOTTEN**  
**Neglected Warriors 25**  
**Underneath Flowery Meadows**

8 POINT

20A 30a \$2 50

**TRACES OF BITTER CONFLICTS MISSED**  
**Beneath Golden Grain Fields**  
**Only Contention's History Remains 10**

6 POINT

22A 32a \$2 25

**BATTLE-THUNDER STILLED BY YEARS OF PEACE**  
**Artillery's Sounds No Longer Heard**  
**Horror's Haunts Changed to Balmy Bowers 76**

**BOLDFACE CELTIC**

---

40 POINT

4A 6a \$7 50

**2 HOmes**

36 POINT

4A 6a \$5 55

**SUN Line 7**

28 POINT

6A 10a \$5 40

**5 BEST Horse**

24 POINT

8A 12a \$4 40

**FINE Steel Ship 67**

18 POINT

10A 15a \$3 35

**82 GRAND Historic Art**

12 POINT

15A 25a \$3 30

**STEAM Pleasure Yacht 93**

10 POINT

25A 40a \$3 95

**24 MODERN Horticultural Clubs**

8 POINT

30A 50a \$3 35

**MAGNIFICENT Frontier Attractions 35**

6 POINT

30A 50a \$2 90

**INTERESTING METROPOLITAN EXHIBITION  
89 Fine Hunting Paraphernalia and Implements**



ROMANESQUE SERIES

30 POINT No. 150

5A 5A \$5 10

DIM STUDIO

24 POINT No. 150

6A 6A \$4 00

BASE 4 RULED

18 POINT No. 150

10A 10A \$3 50

CHRISTMAS CHILD

12 POINT No. 150

14A 14A \$3 00

EXPOSING TO RIDICULE  
INNOCENTS ABROAD 68

10 POINT No. 150

16A 16A \$2 50

KALEIDOSCOPIC IN DIVERSITY  
ENJOY COUNTRY SPORT 340

8 POINT No. 150

18A 18A \$2 00

BEGINS INTERSTELLAR EXCURSION  
HISTORY OF A SPIRIT'S JOURNEY 839

6 POINT No. 151

20A 20A \$2 25

SKETCHES OF JOURNEYS OVER THE WORLD  
FIVE PENCILINGS BY AUDACIOUS REPORTER 792

6 POINT No. 152

20A 20A \$2 25

CIRCLING ROUND THIS LITTLE SPHERE IN EIGHTY DAYS  
25 THOUSAND MILES PASSED IN 11 WEEKS AND 3 DAYS

6 POINT No 153

20A 20A \$2 25

ASSOCIATION OF TOURISTS COMPARING EXPERIENCES WITH BAGGAGEMEN

2579 SATCHELS AND 1367 TRUNKS DEMOLISHED WHILE UNDER THEIR CARE

**Lightface Celtic Condensed No. 120**

—12—

36 POINT

6A \$2 15

6A 6A \$3 90

HUMAN 56 MONOLITH

32 POINT

8A \$2 10

8A 8A \$3 70

NORSEMEN PERFORMERS

30 POINT

10A \$1 90

10A 10A \$3 45

HANDSOME 546 STEAMBOAT

24 POINT

12A \$1 75

12A 12A \$3 15

MERCHANDISE MANUFACTURED

20 POINT

16A \$1 85

16A 16A \$3 20

NORTHWESTERN 6 REPRESENTATIVES

18 POINT

18A \$1 40

18A 18A \$2 50

HUMOROUS TEACHER INSTRUCTING CHILDREN

12 PT. 24A \$1 10 24A 24A \$2 05

10 PT. 32A \$1 35 32A 32A \$2 45

GLORIOUS PHENOMENON 4

REMARKABLE PHONOGRAPHS

8 PT. 36A \$1 25 36A 36A \$2 15

6 POINT NO. 122

48A \$1 30

HERMETICALLY SEALED PRODUCE

SLENDERLY SHAPED STEAMERS 18967

COPPER ALLOY TYPE

TELESCOPIC GOTHIC

15

6 POINT NO. 158

30A \$2 00

PREPLEXED JUDGES AT BABY SHOWS RELIEVED  
FURIOUS DISAPPOINTED MOTHERS 980

6 POINT NO. 157

30A \$1 60

THIRTY-SEVEN BOUNCING BOYS AND GIRLS ON EXHIBITION  
LACK OF PRIZES TO MEET THE DEMAND 75

6 POINT NO. 156

30A \$1 15

THE MYSTERIES OF BREAD BAKING  
PREFERABLE TO LEARNING

6 POINT NO. 155

30A \$1 00

EFFECTS PRODUCING VERY SMALL RESULTS  
STUDENTS GREATEST INTELLECTUAL

THIS SERIES CAN BE USED IN COMBINATION AS CAPS AND SMALL CAPS.

IMPRINT GOTHIC

12-15

6 POINT NO. 121

32A \$0 75

THE BAKER & PEYTON CO., PRINTERS, CHICAGO.

6 POINT NO. 150

48A \$0 75

THE NEVERSLEEP BOOK AND JOB PRINTING CO., WAKEFORD, OHIO.

6 POINT NO. 124

28A \$0 65

STANDARD PRINTING AND BINDING CO., CHICAGO.

COPPER ALLOY IMPRINTS

15

CAST IN ONE PIECE, ANY OF THE FACES HERE SHOWN, AT THE FOLLOWING PRICES:  
100 OF ANY ONE KIND FOR \$8.00 NET. 50 OF ANY ONE KIND FOR \$5.00 NET.

STYLE 1

COMMERCIAL PRINTING CO., ST. LOUIS.

STYLE 2

R. P. STUDLEY & CO., PRINTERS, ST. LOUIS

STYLE 3

THE MAYNARD-GOUGH CO., PRINTERS, WORCESTER.

STYLE 4

TRIBUNE JOB PRINTING CO.

STYLE 5

WOODWARD & TIERNAN PRINTING CO.

STYLE 6

BANNER PTG. CO.

STYLE 7

LITTLE & BECKER, PRINT.

STYLE 8

NIXON-JONES.

IF IMPRINTS ARE WANTED LONGER THAN ONE AND ONE-FOURTH INCHES IN LENGTH, THEY WILL  
HAVE TO BE MADE IN TWO OR MORE PIECES, AND \$3.00 EXTRA PER HUNDRED WILL BE CHARGED  
FOR EACH EXTRA PIECE.

**GOTHIC CONDENSED No. 112**

24 POINT

12A 20a \$3 75

Unkind Demand 4 EXPLORER

18 POINT

16A 24a \$3 20

Several Unqualified Congressmen 5  
RECOGNIZE BELLIGERENTS

12 POINT

24A 36a \$3 08

Wandering Hebrews £67 Helpless Condition  
UNHEARD-OF MONEY INVESTMENT

10 POINT

28A 44a \$2 50

Narrow-Minded Women 93  
FIGHTING STARVATION

8 POINT

40A 62a \$2 70

Englishmen Spending Fortunes 7  
VALUABLE OIL SPRINGS LOST

**COMBINATION CONDENSED GOTHIC**

12 POINT No. 166

16A \$1 50

CONVENIENT COMBINATIONS SHOWN HEREWITH 634

12 POINT No. 165

18A \$1 25

ARTISTIC COMMERCIAL WORK PRODUCED BY APPRENTICE 25

12 POINT No. 164

24A \$1 25

HIGH-GRADE ACTRESSES PERFORM AT MADISON SQUARE THEATRE 678

6 POINT No. 163

32A \$1 50

UNQUESTIONABLE SUPERIORITY IN TYPES 179 FROM AMERICAN TYPE FOUNDERS COMPANY

6 POINT No. 162

40A \$1 25

NICHOLAS SAID THAT HIS BLACK LETTER  
1525 PREVOST OF PARIS

6 POINT No. 161

50A \$1 25

FINEST PRINTER OF THE FIFTEENTH CENTURY  
NICHOLAS JENSON TOURS FRANCE 49

**COMBINATION GOTHIC**

—15—

12 POINT NO. 159 16A \$1 50  
COLDER NORTHERN COUNTRIES

12 POINT NO. 158 16A \$1 50  
SHOWING INEXPRESSIBLE DELIGHT

12 POINT NO. 157 18A \$1 25  
MYSTICAL BELIEF OF THE ROSICRUCIANS

12 POINT NO. 156 24A \$1 25  
ENJOYABLE RAILROAD EXCURSION EXCITEMENT

6 POINT NO. 155 32A \$1 50  
WONDROUS ADVENTURES IN KING SOLOMON'S MINES  
EXPERIENCES OF ALLAN QUATERMAIN 85

6 POINT NO. 154 42A \$1 50  
MECHANICAL AND SCIENTIFIC SCHOOL ENDOWMENT FUND COLLECTED  
SUBSCRIPTIONS TO ENCOURAGE MANUAL TRAINING 375

6 POINT NO. 153 42A \$1 50  
ANNOUNCEMENT OF GENTLEMEN DESIROUS OF RUNNING THE GOVERNMENT  
PECULIAR ELECTION TRICKERIES NOT DESPISED 248

6 POINT NO. 152 50A \$1 25  
DIRECT TRANSPORTATION OF EAST INDIAN MERCHANDISE BY RAILROAD TO SOUTH AMERICA  
MONSTROUS BRIDGE ERECTED ACROSS BEHRING'S STRAITS \$680

6 POINT NO. 151 55A \$1 25  
BEWARE OF ALL COUNTERFEITS OF THE CELEBRATED PATENT CUREALL ODDNAME MEDICINAL PREPARATION  
TAKE A TABLESPOONFUL THREE TIMES BEFORE MEALS  
GUARANTEED TO KILL INSTANTLY IF THE NAME IS NOT BLOWN INTO THE BOTTLE

**GOTHIC No. 127**

—12—

42 POINT

4A \$3 40

HERMONE

36 POINT

5A \$2 70

BRUSHINGS

30 POINT

6A \$2 40

ROMANCINGS

24 POINT

8A \$2 25

HOME 45 GAME

20 POINT

10A \$2 30

KNOWN 83 COURT

18 POINT

12A \$2 00

HEROICS 7 GRANTED

16 POINT

16A \$2 05

MORTUARY 2 MONSTER

**GOTHIC No. 127**

—12—

12 POINT

18A \$1 80

**FURNACES 53 ADVANCING  
MORGANATIC**

10 POINT

24A \$1 80

**PREVENTION FINDS CURATIVES  
HARMONY 84 COMBINED**

8 POINT

32A \$1 90

**MORNING BRINGS BLOSSOMING SHRUB  
MONARCHIAL 57 HALLUCINATION**

6 POINT

36A \$1 60

**EVERMORE ENHANCE INSTRUCTIVE ANGELIQUE  
THROUGH 486 UNIVERSE**

5 POINT ON 6 POINT

36A \$1 30

**CONSTRUCTED ALLEGED ELEVATED RAILWAY OVER PRINCIPAL  
BOULEVARDS CONTEMPLATED 85**

4½ POINT ON 6 POINT

42A \$1 25

**RECORDING EXAMINATIONS EXTRAORDINARY SHOULD GRADUATE COEDUCATORS  
PHONETICALLY ENTHUSIASTICALLY MOMENTOUS  
CAMPOS GAZED HEROICALLY CONTROLLING THE MANIFESTATIONS**

3 POINT ON 6 POINT

48A \$1 10

**EXTRAORDINARY COMMUNICATIONS EXTRADITE GOVERNMENTAL CEREMONIALS CONSTITUTIONALLY  
ENORMOUS THOUGHTFULNESS ENERGETIC 85  
MONSTROSITIES CONDEMNED THROUGH AURORAL AMERICAN ACQUISITIONS**

INTERCHANGEABLE GOTHIC

—12—

48 POINT

3A \$5 90

BURN

36 POINT

4A \$3 90

REGION

32 POINT

4A \$3 00

7 HORSE

24 POINT

6A \$2 45

DANCERS 4

20 POINT

8A \$2 50

NEAR 9 HOME  
BORDERS

COMPLETE SERIES, 14 SIZES, \$30.00.

ALL SIZES LINE AT THE BOTTOM; 12 TO 48 POINT LINE AT BOTH TOP AND BOTTOM.



INTERCHANGEABLE GOTHIC

—12—

18 POINT

12A \$2 30

**REPORT CRANKS**

12 POINT

18A \$2 00

**BEAUTIFUL 45 PRESENT**

10 POINT

18A \$1 35

**MODERN DESIGNED ARTICLES**

8 POINT

24A \$1 35

**97 WEARY PLOWMEN PLOD HOMEWARD**

6 POINT No. 5

36A \$1 70

**DREADFUL UPHEAVING MOTHER EARTH 624**

6 POINT No. 4

36A \$1 45

**PERSEVERANCE OVERCOMES GREATEST DIFFICULTIES  
65 NUMEROUS POLITICAL ORATORS**

6 POINT No. 3

36A \$1 25

**CONTRACTORS DISCOURAGE ENTERPRISING MANUFACTURERS  
FROM BUILDING HANDSOME FACTORIES 4567**

6 POINT No. 2

36A \$1 05

**REFRESHING EVENING BREEZES DRIFTED OVER THE CALM SILVER LAKES  
BRINGING DELIGHTFUL RELIEF TO EXCURSIONISTS 945**

6 POINT No. 1

36A \$0 90

**THOSE WHO ARE GOOD COMPANY FOR THEMSELVES ARE PLEASANT TO OTHERS  
PECULIAR SPIRITUAL MANIFESTATIONS CLEARLY EXPLAINED**

5 SIZES ON 6 POINT BODY, \$6.00;

COMPLETE SERIES, 14 SIZES, \$30.00.

ALL SIZES LINE AT THE BOTTOM; 12 TO 48 POINT LINE AT BOTH TOP AND BOTTOM.

COMBINATION GOTHIC

—15—

24 POINT No. 1528

8A \$3 00

**MONTEZUMA**

24 POINT No. 1527

8A \$3 00

**CALIFORNIANS**

18 POINT No. 1526

12A \$2 50

**GILDED CHARMS**

18 POINT No. 1525

14A \$2 40

**MAGNIFICENT EQUINE**

12 POINT No. 1524

20A \$2 25

**FAMOUS PARADE MUSIC**

12 POINT No. 1523

24A \$2 25

**AMERICAN BOOK PUBLISHERS**

12 POINT No. 1522

24A \$2 25

**TRANSCONTINENT EXCURSION**

12 POINT No. 1521

30A \$2 25

**VALUABLE ROCKY MOUNTAIN MINERAL**

6 POINT No. 1533

40A \$2 00

**NEW PRINTING INVENTIONS AND APPLIANCE**

6 POINT No. 1532

40A \$1 75

**IMBUED WITH THE PASSION FOR STOCK GAMBLING**

6 POINT No. 1531

42A \$1 60

**WEIRD AND FANTASTIC PRODUCT IN ROMANTIC LITERATURE**

6 POINT No. 1530

45A \$1 50

**RUSSIAN RULER AND PUBLIC OFFICERS ALWAYS IN MORE OR LESS PERIL**

6 POINT No. 1529

45A \$1 40

**EXHIBITOR OF ATHLETIC SKILL AND WESTERN PEOPLE QUITE WELCOME \$425**

GOthic No. 1510

—15—

30 POINT

10A \$4 50

DANCE RIDE

24 POINT

12A \$3 20

FINISHED ROOM

20 POINT

14A \$2 80

MOLDING DESIGNS

16 POINT

16A \$2 50

ROMPING OF CHILDREN

14 POINT

18A \$2 25

HUNGRY PEOPLE FEASTING

12 POINT

22A \$2 00

PRINTS CONGRESSIONAL RECORD  
COMPILE ENACTMENTS 95

10 POINT

24A \$1 75

PICTURESQUE LANDSCAPES OF MISSOURI  
HUNTS DELIGHTFUL SCENES 80

8 POINT

28A \$1 35

MANUFACTURER OF FINEST SURGICAL INSTRUMENTS  
HOSPITALS SUPPLIED WITH BEST CUTTERS 82

6 POINT

36A \$1 25

RECONSTRUCTION OF THE ENGLISH LANGUAGE VERY MUCH DESIRED  
INVENT LABOR-SAVING METHODS OF LEARNING GRAMMAR 46

**GOTHIC CONDENSED No. 127**

—12—

48 POINT

4A \$3 00

**HORSE DESIGN**

40 POINT

5A \$2 40

**FLORAL 6 TENDER**

32 POINT

8A \$2 45

**MONKS DESERVED 8**

28 POINT

10A \$2 30

**MEXICAN 345 RESORTS**

24 POINT

12A \$2 15

**38 PATRONS DEMORALIZE  
IMPENETRABILITY**

**GOTHIC CONDENSED No. 127**

—12—

20 POINT

16A \$2 10

**BEDOUIINS PROCURE MISERIES**

18 POINT

18A \$1 90

**DELIGHTFUL CLIMATES ENJOYABLE**

16 POINT

24A \$1 95

**63 LAUGHABLE SITUATION RETURNABLE**

12 POINT

32A \$1 80

**STANDARD UNABRIDGED WORLDS GEOGRAPHY  
PRESENTED WHENEVER DESIRED**

10 POINT

36A \$1 40

**EXTRAORDINARY MANUFACTURING ENTERPRISES LAUNCHED  
PRIVATELY WITHOUT CAPITAL COMPLICATED**

8 POINT

42A \$1 35

**RESTORED FRATERNAL RELATIONS INDUCING COMMERCIAL INTERESTS  
COLUMBIA COLLEGE INTRODUCTION SOCIETY**

6 POINT

48A \$1 25

**DEMORALIZED ARMENIAN SETTLEMENTS  
TURKISH BRUTALITIES 678  
HUMANE INFLUENCES INTERCEDING**

5 POINT ON 6 POINT 56A \$1 30

**PRINTERS DISCOVER HISTORICAL MANUSCRIPTS  
UNDERGROUND CHAMBERS  
NUMEROUS EVENING NEWSPAPERS SOLD**

**GOTHIC CONDENSED No. 128**

48 POINT

4A \$3 55

**HURT BIRDS**

42 POINT

5A \$2 80

**HERBIVOROUS**

36 POINT

8A \$3 10

**BRUSH 4 CORKS**

30 POINT

10A \$2 65

**CURIOUS NOVELTY 4**

24 POINT

12A \$2 25

**MONSTER 75 IMPEDED  
MAGNIFICENTLY**

**GOTHIC CONDENSED No. 128**

—12—

20 POINT

16A \$2 45

**BUILDING FRUIT STANDS**

18 POINT

18A \$2 10

**ROMANESQUE 94 PERFORMERS**

16 POINT

24A \$2 10

**63 LIBERAL INDUCEMENTS OFFERED**

12 POINT

32A \$2 10

**GREAT BARGAINS 459 WINTER GLOVES**

10 POINT

36A \$1 70

**827 MAIDEN WANDERING THROUGH LEAFY LANES  
MOUNTING MONTANA MOUNTAINS**

8 POINT

42A \$1 65

**ESTIMATES AND SPECIMENS FURNISHED IMMEDIATELY  
HANDSOME STEAMERS BURNED 34567**

6 POINT

48A \$1 55

**DEPARTING POLITICIAN WALKING  
SILVER EXHIBITS 945**

5 POINT ON 6 POINT 56A \$1 45

**REMARKABLE INDUCEMENTS OFFERED  
NUMEROUS HARDSHIPS 5678**

**CHAMFER CONDENSED**

---

96 POINT

5A \$12 80

**MOWERS**

84 POINT

5A \$10 30

**BOUNDING**

72 POINT

7A \$9 90

**PRESIDENTS**



CHAMFER CONDENSED

60 POINT

7A \$7 15

SOUND HOMES

48 POINT

7A \$6 15

DRIVERS

40 POINT

10A \$4 90

INDULGED

36 POINT

10A \$3 75

ENCOURAGE

28 POINT

14A \$4 00

DOMESTICATE

22 POINT

18A \$3 00

CLOTHING HOUSES

18 POINT

30A \$3 60

LIBERTY PROCLAIMED

12 POINT

36A \$2 60

GREAT INTENTIONS PURSUED

10 POINT

36A \$2 00

JUVENILE YOUNG EXPERIMENTERS

8 POINT

45A \$2 00

GREAT EUROPEAN RESTAURANT SUPPERS  
FAMOUS MUSICAL ARTISTS

6 POINT

52A \$2 00

PROFESSOR GATHERER'S SWEET EXTRACT OF ROOTS  
MEDICINAL PROPERTIES DEFINED

1234567890

1234567890

**GOTHIC CONDENSED No. 122**

12

72 POINT

3A 6a \$10 85

3A \$4 25

**BIND Grain**

60 POINT

3A 6a \$7 70

3A \$2 90

**FERN 4 Brew**

48 POINT

4A 8a \$6 10

5A \$2 65

**HER NET Gain 6**

42 POINT

6A 12a \$5 90

5A \$2 05

**53 REMORSE Pains**

36 POINT

8A 16a \$6 40

5A \$1 45

**PENS RUST Entire 84**

SMALL CAPS NOT SENT UNLESS EXPRESSLY ORDERED.

**GOTHIC CONDENSED No. 122**

12

24 POINT

10A 20a \$3 85 6A \$1 05

**NORTHERN Lumber District  
ENRICHED FOREIGNER**

20 POINT

10A 20a \$3 10 8A \$1 00

**RETURNED Patriots Derive Fame  
HONORED 4 PRESIDENT**

18 POINT

12A 24a \$2 80 8A \$0 70

**MERCHANTS DESIRE Personal Mention  
24 BEAUTIFUL THOUGHTS**

12 POINT

18A 36a \$2 30 10A \$0 50

**Combine Receive Benefit 6 RHYMES WITH REASON  
PHILOSOPHIC MANIFESTATION 365**

10 POINT

20A 40a \$1 75

**Transcient Printers Determine Reasonable Technical Measures  
Situations Considered Monotonous  
EDITORIAL COMMENTS GLORIOUSLY RECEIVED**

SMALL CAPS NOT SENT UNLESS EXPRESSLY ORDERED.

**GOTHIC CONDENSED No. 129**

12-15

★72 POINT

4A 6a \$11 50

**SINK Ours**

★60 POINT

4A 6a \$8 50

**Made FRESH**

48 POINT

6A 10a \$6 35

**BRIGHT Scholar**

42 POINT

10A 12a \$5 90

**Standard DEMANDS**

36 POINT

10A 12a \$4 60

**REFORMED Probable**

**GOTHIC CONDENSED No. 129**

24 POINT

15A 20a \$4 00

**Standard Doctrines Enforced  
FRENCH REPUBLIC**

20 POINT

15A 20a \$2 65

**Choicest American Features Coveted  
ANCIENT REMARKS DESIRED**

18 POINT

15A 25a \$2 10

**Continuously Unrewarded Christmas Dreaming  
GRANDEST BELOVED SECRETS**

12 POINT

20A 30a \$1 85

**Numerous Strange Inventors Protesting Outrageously  
INSINUATING MASQUERADE COSTUMES**

\*10 POINT

20A 40a \$1 75

**Complimented Organizations Remained Handsomely Regarded  
ORIGINAL ELOQUENCE DISCOURAGED**

**GOTHIC CONDENSED No. 123**

36 POINT

6A 12a \$5 90

**Handsome Monster  
EXCURSION**

30 POINT

10A 20a \$4 90

**Magnificent Improvement  
GRAND 45 MARCH**

24 POINT

12A 24a \$4 00

**Diamond Combination Exposed  
976 FINEST SERIES**

18 POINT

12A 24a \$2 95

**Extraordinary Commercial Situation  
Popular Concerts 78  
SEVENTH OCEAN EXCURSION**

**GOTHIC CONDENSED No. 123**

14 POINT

18A 36a \$3 15

**Remarkable Railroad Station Extensions  
Enterprising Newspaper 74  
NORTHERN TRUST COMPANY**

12 POINT

18A 36a \$2 55

**Minor Speculators Accumulate Vast Amounts  
Individual Securities 627  
NORTHWEST MARKETS REVIEWED**

10 POINT

24A 48a \$2 55

**Delivering Contributions from Charitable Aid Societies  
Rushing German Soldiers 79  
AMERICAN HISTORICAL INSTITUTIONS**

8 POINT

32A 64a \$2 80

**Experience Proves that the Apprentice Foreshadows the Workman  
457 Encountered Difficult Controversies  
LATEST SERIES EGYPTIAN ORNAMENTS RECEIVED**

6 POINT

32A 64a \$2 35

**The World is Full of Fools and Those Who Would Not Wish to See One Must  
Not Only Shut Themselves Up Alone But Must 839  
SPRINGTIME RAMBLES THROUGH SOUTHERN COUNTRIES**

**GOTHIC CONDENSED No. 124**

48 POINT

4A 8a \$6 40

**GRAND Shows**

42 POINT

4A 8a \$5 05

**Coreans Remain  
GRAND 42**

36 POINT

6A 12a \$5 50

**Consumer Generate  
MONSTERS 86**

30 POINT

8A 16a \$4 35

**Introducing Receptacles  
MONGOLIAN 45**



**GOTHIC CONDENSED No. 124**

12

24 POINT

12A 24a \$4 45

Monastic Costumes Becoming  
**MAIDEN 82 HELPERS**

18 POINT

12A 24a \$3 05

Blessings Descending Generously  
**BEFORE 68 RICHES**

12 POINT

18A 36a \$2 65

Victorious Multitude Marched Triumphantly  
**MILITARY ACHIEVEMENTS**

10 POINT

24A 48a \$2 65

Decorated Foreign Substance Illuminated Beautifully  
**MODERATE DESCENDANT INCLINATION**

8 POINT

32A 64a \$2 85

Eternal Blessings Bestowed Meritoriously on Hastening Pilgrims  
**GLORIOUS IMMORTALITY COMPREHENDED**

6 POINT

32A 64a \$2 30

Removing Incumbrances from Properties Conveyed Legitimately to Descendants  
**MODESTLY SUSTAINED 45 NUMERICALLY ORIGINATING**

**Gothic Extra Condensed No. 122**

— 12 —

72 POINT

4A 8a \$10 75

**HUMAN** Bones

60 POINT

5A 10a \$9 65

**MORE 86** Dream

48 POINT

6A 12a \$9 20

**HARPIST** Charmer

42 POINT

6A 12a \$6 90

**FAMOUS** Turf Writer 45

36 POINT

6A 12a \$4 80

**CONSECRATION** Presentations

**Gothic Extra Condensed No. 122**

12

30 POINT

8A 16a \$4 80

Elaborate Montana Quartz Mines  
RAREST ORIENTAL ROSES

24 POINT

10A 20a \$4 20

Departing Worshipers Receiving Prayers  
REMARKABLE 47 DISTRIBUTION

22 POINT

12A 24a \$4 00

Reverse Side Having Many Revolving Chambers  
NEPTUNE SEEMS ENRAGED 873

18 POINT

16A 32a \$3 80

Constantly Exhibiting Wonderful Miscellaneous Inventions  
PROCURING RENOWNED MEDICINES 56789

12 POINT

18A 36a \$2 35

Revised Histories of Many Celebrated Modern Characters Nearly Ready for Publication  
CHARITABLE LADIES DISTRIBUTING WINTER CLOTHING 3456

**Gothic Extra Condensed No. 150**

—15—

48 POINT

5A 8a \$5 00

**HONORABLE** Securities

40 POINT

6A 9a \$4 50

Bidder Without **PROPERTY**

30 POINT

10A 16a \$4 50

**SPIRITUALIST** Medium Pretenders

24 POINT

12A 18a \$3 50

Discussing Tiresome **POLITICAL SPEECHES**

18 POINT

18A 24a \$3 25

**GERMAN BROTHERHOOD** Governing Kingdoms

12 POINT

20A 40a \$3 00

This Handsome Face Useful 72 **COPPER ALLOY TYPE FOR SALE**

10 POINT

20A 38a \$2 75

**TIME WITH SILENT FOOTSTEPS** Many Happy Days Forever Fled from Us

8 POINT

22A 32a \$2 50

Travelers Braving the Dangers of the **EXPLORATIONS WITHIN THE ARCTIC CIRCLE** 48

**JOHNSON GOTHIC**

15

16 POINT

16A 24a \$4 00

MELANCHOLY AUTUMN DAYS  
Indiscreet Friends Reproved

14 POINT

14A 36a \$3 75

GREATEST OF MEN VULNERABLE  
Architect of His Own Fortune 2

12 POINT

15A 40a \$3 50

CONSPICUOUS BY THEIR ABSENCE  
Determined and Unrelenting Taskmaster

10 POINT

18A 45a \$3 00

WEDDING OUTFITS FOR THE YOUNG LADIES  
Latest, Most Correct and Exclusive Styles

8 POINT

20A 50a \$2 50

HE INDULGED IN LOUDNESS AND IRREVERENCE  
Sure Mark of a Low and Unregenerate Nature \$82

6 POINT

24A 60a \$2 25

HARVESTING MACHINERY BOUGHT AT VERY LOW PRICES  
Farmer and Merchant Much Gratified by Good Crops

**GOTHIC No. 124**

12

48 POINT

4A 6a \$7 65

REMiNder

36 POINT

5A 8a \$5 75

Honor Deals  
NUMBER

30 POINT

6A 10a \$5 15

Bond 4 House  
FORTUNE

24 POINT

8A 16a \$4 50

Encores Tendered  
HERDSMEN

**GOTHIC No. 124**

12

18 POINT

12A 24a \$3 50

President Received Securities  
Investment 42 Drawn  
SUBURBAN TRANSFER

12 POINT

18A 36a \$2 50

Revised Dictionaries Caused Unusual Demand  
Seminaries Endorse Education  
UNABRIDGED EDITION POPULAR

10 POINT

20A 40a \$2 10

Ministerial Invocations Received Honorable Mention  
Deceased Members Eulogized  
369 BEAUTIFUL PROGRAM RENDERED

8 POINT

24A 48a \$2 05

Examination Invites Criticism from Distinguished Connoisseurs  
Ancient Classical Lore Perpetuated  
EXHIBITED PAINTINGS DELIGHT MULTITUDES

6 POINT

32A 64a \$2 15

Decorous Maidens Find Lucile Interesting Material for Pleasant Contemplation  
Holiday Gifts Comprising Eminent Productions  
ENRICHED MERCHANTS MANIPULATE ENGLISH STOCKS

**GOTHIC No. 125**

12

48 POINT

4A 8a \$9 30

**PREsume**

42 POINT

4A 8a \$7 10

**BEN 4 Runs**

36 POINT

6A 12a \$7 10

**Eastern Dudes  
DECISION**

30 POINT

8A 16a \$5 20

**Heretics Ostracized  
MODERN 24**

24 POINT

10A 20a \$4 35

**Desire Honest Method  
63 NORMANS**



**GOTHIC No. 125**

12

18 POINT

12A 24a \$3 80

**Receive Christmas Presents  
PLUMP 4 GANDER**

14 POINT

16A 32a \$2 80

**Peasants Denounce Aristocratic Grandeur  
LIGHTER BURDENS**

12 POINT

18A 36a \$2 50

**Extended Mercies Shown Unlawful Members  
258 FIREMAN BADLY INJURED**

10 POINT

24A 48a \$2 65

**Leonora Divorces Falsified Education From Science  
POLITICAL AMBITIONS THWARTED**

8 POINT

24A 48a \$2 30

**Endeared Ruralistic Tendencies Deserve Severe Criticism  
Farmers Contradict Measurements  
BOHEMIAN PROPOSED ENCAMPMENT 85**

6 POINT

32A 64a \$2 45

**Facilitate Governmental Monometalism Schemes Through Manipulation  
Interest Awakened Throughout Financial Circles  
ENGLISH CAPITALISTS WITHDRAW THEIR INVESTMENT**

**GOTHIC No. 122**

—12—

48 POINT

3A 6a \$9 25

5A \$5 45

**Decimal**

42 POINT

4A 8a \$8 00

4A \$3 40

**MINERS 3**

36 POINT

4A 8a \$6 60

5A \$3 10

**EXCUSED**

30 POINT

5A 10a \$5 35

6A \$2 55

**DUMP Cart 8**

24 POINT

8A 16a \$5 35

8A \$1 85

**Hudson MAIDEN  
HUNTERS**

SMALL CAPS WITH ALL SIZES EXCEPT 5 POINT.

**GOTHIC No. 122**

—12—

20 POINT

10A 20a \$4 90

10A \$1 70

**HERO UNDER Ocean**

18 POINT

10A 20a \$3 15

10A \$1 25

**STOLEN Security Bonds  
WORLD MAKER**

12 POINT

16A 32a \$3 65

16A \$1 20

**Unconventional ADVERTISER  
REMOTE SCIENCE**

10 POINT

18A 36a \$3 15

18A \$1 15

**Modern Hercules DISCARDS CIGAR  
REPULSIVE FACE 95**

8 POINT

24A 48a \$3 45

24A \$1 10

**Emperor Presents FRIEND WITH DIAMONDS  
ELEMENTARY STUDIES**

6 POINT

24A 48a \$2 65

24A \$0 90

**Disgruntled Politicians REFUSE HONORARY OFFICES  
2345 UNDER HYPNOTIC INFLUENCE**

5 POINT

24A 48a \$2 90

**Unscrupulously Disregarded Swiftly Passing Golden Moments  
INVIGORATING EXERCISES RESTORE FRESHMEN**

SMALL CAPS NOT SENT UNLESS EXPRESSLY ORDERED.

ROYAL GOTHIC

12

48 POINT

4A 8a \$8 95

**DOG Meat**

36 POINT

5A 10a \$7 05

**NEAT 8 Girl**

30 POINT

6A 12a \$5 25

**RESIN Burned**

24 POINT

8A 16a \$5 05

**Beautiful Flower  
NOURISHED**

20 POINT

10A 20a \$4 80

**Entertain Ministers  
REJUVENATE**

ROYAL GOTHIC

— 12 —

18 POINT

10A 20a \$3 15

**Ninth Dose Proved Fatal**  
**DECIDE SUBJECT**

12 POINT

16A 32a \$3 15

**Disastrous Hailstorm Predicted**  
**SOUTHERN 42 ARKANSAS**

10 POINT

18A 36a \$2 70

**Natural Amiable Qualities Invulnerable**  
**Friends Receive Honors**  
**SOCIETY EMBRACES DUKEDOM**

8 POINT

24A 48a \$3 05

**Mountainous Scenes Lure American Tourist**  
**Fortunes Facilitate Pleasure**  
**GLACIERS CONTINUE FORMIDABLE 38**

6 POINT

24A 48a \$2 25

**Resolute Characters Explore Unknown Northern Regions**  
**Governments Contribute Paraphernalia**  
**67 EXPEDITION REPORTING DISCOVERIES**

**MID-GOTHIC SERIES**

—15—

72 POINT

3A 4a \$14 00

**Broken**

60 POINT

3A 4a \$10 00

**ENDURE**  
**Stops**

54 POINT

3A 5a \$8 00

**SIX MEN**  
**Muscle**

MID-GOTHIC SERIES

—15—

48 POINT

4A 6a \$7 25

**CLINTONIA**  
**Mansion**

42 POINT

5A 8a \$6 50

**DARK BELLE**  
**Hercules**

36 POINT

6A 9a \$5 00

**MEMPHIS MAID**  
**First Engine**

30 POINT

7A 10a \$4 25

**MONEY GRABBERS**  
**Three Card Men**

MID-GOTHIC SERIES

15

24 POINT

9A 12a \$4 00

**MAGAZINE PUBLISHER**  
**Account Books 81**

18 POINT

12A 16a \$3 50

**SPECIMENS OF FINE WORK**  
**Prayer for Printers**

14 POINT

12A 18a \$3 25

**PUNCTUALITY GREAT IN BUSINESS**  
**Still Tongue Maketh a Full Stick**

12 POINT

16A 20a \$3 00

**SEEST THOU A MAN DILIGENT IN BUSINESS**  
**He Shall Stand Before Kings**

10 POINT

20A 26a \$2 75

**HABITUAL LAGGARDS SOON REQUESTED TO RESIGN**  
**Dropped Letter Must be Distributed at Once**

8 POINT

22A 30a \$2 50

**CONSULT THE FOREMAN FIRST UPON ALL BUSINESS MATTERS**  
**Affected Dispatch is one of the Business Faults**

6 POINT

24A 36a \$2 25

**LET MY DEATH COME FROM SPAIN FOR THEN IT WILL BE LONG IN COMING**  
**Time is the Measure of Business as Money is of Wares, said Bacon**



**TAYLOR GOTHIC**

---

48 POINT

4A 5a \$7 75

**Mast Head**

36 POINT

5A 8a \$5 50

**Boston 3 Globe**

24 POINT

10A 15a \$4 50

**Generous 9 Christmas  
PRAISE GIVING**

18 POINT

12A 20a \$4 00

**Produce Century Flowers 2  
YEARS OF STUDY**

12 POINT

16A 25a \$3 25

**Thanksgiving Proclamation Annually 89  
CHARLESTOWN MONUMENT**

10 POINT

20A 30a \$3 00

**Middle West Customers £34 Demanding Novelties  
ROMPING THROUGH GARDENS**

**LINING GOTHIC No. 43**

36 POINT

6A 9a \$7 10

Remembers  
SOUND

30 POINT

8A 12a \$6 60

Home Bought  
MEMBER

24 POINT

10A 15a \$5 20

Nomads Ramble  
ROVERS

18 POINT

14A 25a \$4 95

Mansions Remodeled  
ARCHITECTS

**LINING GOTHIC No. 43**

12 POINT

25A 40a \$4 20

**Industrial and Financial Crashes  
REFORM AGITATED**

9 POINT

36A 50a \$3 90

**Modern Improvements in Roofing Material  
THATCHED MANSIONS**

8 POINT

36A 55a \$3 90

**Relaxation and Repose of Hard-Worked Miners  
HONORABLE COMPETENCY**

6 POINT No. 417

60A 70a \$4 00

**Oblique Inclinations of the Base with the Horizon Discussed  
THEODOLITE REPEATING CIRCLE**

6 POINT No. 416

60A 70a \$3 70

**Changes in the Atmospheric Strata Exemplified by Noted Astronomers  
MICROSCOPIC VERNIER INDICATIONS COMPARED**

6 POINT No. 415

60A \$2 25

**CIRCUMFERENCE OF THE TERRESTRIAL SPHERE SCIENTIFICALLY CONSIDERED BY EXPLORERS  
SOME INSTANCES OF INACCURATE GEODETIC OPERATIONS**

6 POINT No. 414

60A \$2 25

**CALCULATIONS BY AN INVARIABLE AND CONSTANT SYSTEM OF MEASUREMENT WITH IMPROVED APPARATUS  
SUPERIORITY OF THE MODERN METHODS AND APPLIANCES**

LINING GOTHIC No. 44

---

36 POINT

6A 8a \$7 65

Monument  
BANDS

30 POINT

8A 12a \$6 95

Amusements  
HONOR

24 POINT

10A 15a \$5 65

Wearied Soldier  
RESTING

18 POINT

14A 22a \$4 75

Humorous Managers  
DESIRABLE

**LINING GOTHIC No. 44**

---

12 POINT

22A 40a \$4 10

**Disturbing Musical Milkmaids  
HILLSIDE SPORTS**

10 POINT

28A 45a \$4 05

**Investigating Devastated Properties  
MORNING RAMBLES**

8 POINT

36A 55a \$3 80

**Automatic Machine and Pickpocket Detectors  
INTERESTING LECTURES**

6 POINT No. 422

50A 70a \$4 45

**Contentment and Harmony Nestle on the Hearthstone  
SECURITY FOSTERED PEACE**

6 POINT No. 421

50A \$2 35

**DESPERATE BRIGANDS CAPTURED AND CORRECTED  
MOUNTED GUARDS SUMMONED**

6 POINT No. 420

50A \$1 70

**THRASHELS AND COWHIDE WHIPS REQUIRED FOR SERVICE  
SCOURING THE COUNTRY FOR BURGLARS**

6 POINT No. 419

50A \$1 40

**HAPPY HOUSEWIVES OVERHAULING BEDCLOTHES WITHOUT DIFFICULTY  
POLICEMEN HUNTING MIDNIGHT PICKPOCKETS**

6 POINT No. 418

50A \$1 35

**CARELESSNESS IN FASTENING WINDOW SHUTTERS AND BASEMENT CLOSETS  
SNEAKTHIEF RESPECTFULLY RECOMMENDED 1234567890**

**LINING GOTHIC No. 45**

---

36 POINT

4A 7a \$6 80

**Resources  
BANK**

30 POINT

6A 9a \$6 35

**Entertaining  
MUSIC**

24 POINT

8A 12a \$5 20

**Honest Person  
FRIENDS**

18 POINT

12A 18a \$4 45

**European Countries  
EXCURSION**

**LINING GOTHIC No. 45**

—4—

12 POINT

20A 30a \$4 00

**Examining the Latest Styles  
MODEST DAMSELS**

9 POINT

25A 45a \$3 85

**Humorous Yarns and Fishing Stories  
CHARMING SIMPLICITY**

8 POINT

36A 55a \$3 80

**Mental Repose Amid the Handiwork of Nature  
MIDSUMMER HOLIDAYS**

6 POINT No. 427

[45A 70a \$4 45

**Liberal Pensions Recommended for Disabled Soldiers  
LEGISLATIVE ENACTMENT**

6 POINT No. 426

45A \$2 10

**ESCAPING FROM THE EMBRACES OF A WILD BEAST  
STRUGGLING AGAINST POWER**

6 POINT No. 425]

45A \$1 90

**DESCRIPTIONS OF PARIS DURING THE FRENCH REVOLUTION  
DINNER TIME AMONG THE INSURGENTS**

6 POINT No. 424

45A \$1 55

**ABANDONMENT OF TINDER FOR COOKING, HEATING AND WASHING  
YELLOWSTONE GEYSER WATER COMPANY**

6 POINT No. 423

45A \$1 45

**ARTILLERY FORBIDDEN AND ARMIES NOT TO EXCEED ELEVEN THOUSAND MEN**

1 2 3 4 5 6 7 8 9 0

PHILADELPHIA LINING GOTHIC

---

48 POINT No. 648

7A 9a \$6 50

FRENCH Saloons

36 POINT No. 636

8A 10a \$5 50

Grandeur Overdone  
EXHIBITIONS

30 POINT No. 630

12A 15a \$5 00

Chased Medals Granted  
REMUNERATION

24 POINT No. 624

16A 24a \$4 50

Handsome Scenes Retouched  
Outline Picture  
NOTORIETY ACQUIRED



**PHILADELPHIA LINING GOTHIC**

— 4 —

18 POINT NO. 618

22A 32a \$4 25

**Enthusiastic International Discourse  
MOMENTOUS QUESTIONS**

14 POINT NO. 614

30A 42a \$4 00

**Temerarious Parliamentary Consideration  
UNCONCERNED STATESMEN**

12 POINT NO. 612

35A 52a \$3 75

**Influential and Eloquent Citizens Renominated  
DEFENDING MUNICIPAL POLICIES**

10 POINT NO. 610

45A 60a \$3 50

**Reminiscences of Twelve Celebrated European Travelers  
SUPERIOR JUVENILE LITERATURE COMPILED**

8 POINT NO. 608

52A 70a \$3 25

**Professional Individuals Always Guaranteed Permanent Occupations  
SHREWD AND CONSCIENTIOUS EMPLOYER OF WORKMEN**

6 POINT NO. 606

60A 70a \$3 00

**Renowned and Benevolent Financiers Upholding the Credit of Great Institutions  
INEVITABLE RESULT OF STOCK INFLATION MANIFESTED**

1 2 3 4 5 6 7 8 9 0

**PHILADELPHIA LINING GOTHIC**

48 POINT No. 748

6A 9a \$7 50

**BANDS Joined**

36 POINT No. 736

8A 10a \$6 50

**Hideous Dreams  
NIGHTMARE**

30 POINT No. 730

10A 15a \$5 50

**Musicians Resolute  
ENTERTAINERS**

24 POINT No. 724

14A 20a \$4 75

**Graceful Ocean Steamer  
PROUD COXSWAIN**

**PHILADELPHIA LINING GOTHIC**

18 POINT NO. 718

18A 28a \$4 50

**Indesinent Society Grumblers  
DISCONTENTMENT**

14 POINT NO. 714

25A 35a \$4 25

**Frequent Extravagance Detected  
GUARDIANS FRIGHTENED**

12 POINT NO. 712

30A 45a \$4 00

**Advancing Microscopical Investigation  
SUPREMACY ACKNOWLEDGED**

10 POINT NO. 710

35A 50a \$3 75

**Cash Registers with Indispensable Multiplier  
INGENIOUS CONTRIVANCES DEVISED**

8 POINT NO. 708

45A 60a \$3 50

**Residents Secure Lasting Results by Concerted Action  
EXTORTIONATE COMPANIES CONDEMNED**

6 POINT NO. 706

50A 60a \$3 25

**Searching Investigation Inaugurated by Outraged Constituents  
OBNOXIOUS LEGISLATIVE REQUIREMENTS**

**1 2 3 4 5 6 7 8 9 0**

PHILADELPHIA LINING GOTHIC

48 POINT NO. 848

6A 8a \$8 50

**FINE Nurse**

36 POINT NO. 836

7A 10a \$7 00

**Honest Stock  
OPINIONS**

30 POINT NO. 830

9A 12a \$6 00

**Informal Demand  
PRECOCIOUS**

24 POINT NO. 824

14A 20a \$5 25

**Wonderful Performers  
HASTY NOTION**

**PHILADELPHIA LINING GOTHIC**

18 POINT NO. 818

16A 26a \$4 75

**Excursion Rate Decreased  
MODERATE OUTLAY**

14 POINT NO. 814

25A 35a \$4 50

**Unraveling Crude Manuscript  
ZEALOUS PRINTERS**

12 POINT NO. 812

30A 42a \$4 25

**Harmonious Productions Finished  
AUTOMATIC DEPARTURE**

10 POINT NO. 810

35A 50a \$4 00

**Lovers Ramble Through Secluded Gardens  
BACHELORS PLEDGE PROTECTION**

8 POINT NO. 808

45A 60a \$3 75

**Unimpeached and Cherished National Resolutions  
EULOGIZING DISTINGUISHED ENACTMENTS**

6 POINT NO. 806

45A 60a \$3 50

**Bostonian Emulates the Logic of Wonderful Forefather  
PATRIOT ADMINISTERS STINGING REBUKE**

**1 2 3 4 5 6 7 8 9 0**

PHILADELPHIA LINING GOTHIC

---

48 POINT No. 948

5A 7a \$8 50

GUN Shot

36 POINT No. 936

6A 9a \$7 00

Noble Gains  
DESIGN

30 POINT No. 930

8A 10a \$6 00

Decided Craze  
MUSICALE

24 POINT No. 924

12A 16a \$5 25

Quick Road Home  
HORSE RUNS

**PHILADELPHIA LINING GOTHIC**

18 POINT NO. 918

14A 22a \$4 75

**Complete Nomination  
ENTICEMENT**

14 POINT NO. 914

20A 30a \$4 50

**Giving Evidence of Truce  
FOREIGN RUMORS**

12 POINT NO. 912

25A 38a \$4 25

**Residents Honored Centurion  
REMARKS DEFINED**

10 POINT NO. 910

30A 45a \$4 00

**Shapely Contour and Outline Letters  
GORGEOUS HANDIWORK**

8 POINT NO. 908

38A 50a \$3 75

**Eminent Decorators of Famous Parchment  
INDEPENDENT IMMIGRATION**

6 POINT NO. 906

40A 50a \$3 50

**Midwinter Carnival Dazzling Canadian Frontiersmen  
DISPLAYING OSTENTATIOUS POMPOSITY**

1 2 3 4 5 6 7 8 9 0

PHILADELPHIA LINING GOTHIC

48 POINT NO. 1048

4A 6a \$9 25

**BIG Maid**

36 POINT NO. 1036

6A 8a \$7 75

**Rich Cake  
MINCE**

30 POINT NO. 1030

7A 10a \$6 50

**Bland Maids  
PURITAN**

24 POINT NO. 1024

10A 15a \$5 50

**Unruly Crowds  
DISORDER**



**PHILADELPHIA LINING GOTHIC**

18 POINT No. 1018

14A 20a \$5 00

**Quickly Concluded  
SUNNY DAYS**

14 POINT No. 1014

18A 26a \$4 75

**Slumber Comfortably  
ANGELS DREAM**

12 POINT No. 1012

22A 10a \$4 50

**Deacons Criticise Editors  
MANKIND REBUKED**

10 POINT No. 1010

25A 40a \$4 25

**Combine Refuses to Heat Cars  
SUBURBAN CONTRACT**

8 POINT No. 1008

35A 45a \$4 00

**Discourses on Developing the Muscle  
CALISTHENIC DEMONSTRATION**

6 POINT No. 1006

38A 50a \$3 75

**Calculation Made Upon Scientific Principles  
LONGITUDINAL MEASUREMENTS**

1 2 3 4 5 6 7 8 9 0

PHILADELPHIA LINING GOTHIC

48 POINT No. 1148

4A 6a \$10 00

**REmain**

36 POINT No. 1136

5A 9a \$8 50

**Coal Bins  
HUGE**

30 POINT No. 1130

7A 10a \$7 00

**Meat Store  
GRAND**

24 POINT No. 1124

10A 15a \$6 00

**Golden Record  
ENDURING**

**PHILADELPHIA LINING GOTHIC**

18 POINT NO. 1118

12A 18a \$5 25

**Silver Mania Cure  
WEST BOUND**

14 POINT NO. 1114

16A 26a \$5 00

**Regiment Organized  
INDEPENDENT**

12 POINT NO. 1112

20A 32a \$4 75

**Eastern Coffee Houses  
BRIGHT OPENING**

10 POINT NO. 1110

25A 40a \$4 50

**Comedian Satisfies Audience  
JOCULAR HARLEQUIN**

8 POINT NO. 1108

35A 45a \$4 25

**Magnanimous Billiard Tournaments  
ENTRANCING RECREATION**

6 POINT NO. 1106

35A 50a \$4 00

**Prosperity Attends Sedulous Researcher  
KNOWLEDGE FOR EVERYBODY**

**1 2 3 4 5 6 7 8 9 0**

PHILADELPHIA LINING GOTHIC

---

48 POINT NO. 1248

4A 5a \$9 25

SISters

36 POINT NO. 1236

5A 7a \$7 75

Zinc Box  
SEND

30 POINT NO. 1230

6A 9a \$6 50

Rude Chap  
ODIUM

24 POINT NO. 1224

9A 12a \$5 50

Gentle Dame  
COURTED

**PHILADELPHIA LINING GOTHIC**

18 POINT NO. 1218

12A 15a \$5 00

**Operatic Chorus  
HARMONIZE**

14 POINT NO. 1214

14A 22a \$4 75

**Gimcrack Dancers  
BURLESQUE**

12 POINT NO. 1212

18A 28a \$4 50

**Violent Storms Cease  
ROUGH SEASON**

10 POINT NO. 1210

22A 35a \$4 25

**Cautious Bridge Mechanic  
FORDING STREAMS**

8 POINT NO. 1208

28A 42a \$4 00

**Ninth Alaskan Excursion Started  
ESQUIMAUX GUARDIANS**

6 POINT NO. 1206

30A 45a \$3 75

**Moderate Charges for Home Comforts  
JUDICIOUS HOTEL MANAGER  
1 2 3 4 5 6 7 8 9 0**

PHILADELPHIA LINING GOTHIC

48 POINT No. 1348

3A 4a \$10 00

**HEars**

36 POINT No. 1336

4A 6a \$8 50

**Old Urn  
HIRE**

30 POINT No. 1330

6A 8a \$7 00

**Iron Rust  
STAIN**

24 POINT No. 1324

7A 12a \$6 00

**Metal Clock  
BRONZE**

**PHILADELPHIA LINING GOTHIC**

18 POINT NO. 1318

10A 14a \$5 25

**Modest Gowns  
MORNING**

14 POINT NO. 1314

14A 22a \$5 00

**Sealskin Dolman  
REDUCTION**

12 POINT NO. 1312

18A 28a \$4 75

**Water Supply Fails  
DUSTY FOUNT**

10 POINT NO. 1310

20A 35a \$4 50

**Modest Percale Necktie  
COLORS BLENDED**

8 POINT NO. 1308

25A 40a \$4 25

**Strange Boulevard Emporium  
EARNEST MERCHANT**

6 POINT NO. 1306

28A 40a \$4 00

**Ornamented Decanter Specialties  
BOHEMIAN MASTERPIECE  
1 2 3 4 5 6 7 8 9 0**

PHILADELPHIA LINING GOTHIC

---

48 POINT NO. 1448

3A 5a \$11 25

**BRing**

36 POINT NO. 1436

5A 7a \$9 75

**Pot Pie  
BIRD**

30 POINT NO. 1430

6A 9a \$8 25

**Bold Hen  
CHICK**

24 POINT NO. 1424

9A 12a \$7 00

**North Zone  
HUNTER**



PHILADELPHIA LINING GOTHIC

18 POINT No. 1418

12A 15a \$6 00

**Silver Watch**  
**GENUINE**

14 POINT No. 1414

16A 22a \$5 50

**Diluvian Hurdles**  
**ANTERIOR**

12 POINT No. 1412

16A 26a \$5 00

**Smart Cake Baker**  
**HONEY TARTS**

10 POINT No. 1410

22A 32a \$4 75

**National Bank Director**  
**SOUND FINANCE**

8 POINT No. 1408

25A 40a \$4 50

**Lucrative Situation Desired**  
**POLITICAL SINECURE**

6 POINT No. 1406

28A 45a \$4 25

**Tendering Customary Receptions**  
**ENTHUSIASTIC BACKERS**  
**1 2 3 4 5 6 7 8 9 0**

LINING GOTHIC EXTENDED No. 40

36 POINT

4A 6a \$7 10

**BIG Sign**

30 POINT

5A 7a \$5 15

**Hear MEN**

24 POINT

7A 10a \$4 50

**FAST Racers**

18 POINT

10A 14a \$4 30

**Native GROUPS**

14 POINT

12A 18a \$3 50

**MODERN Steamer**

12 POINT

14A 22a \$3 40

**Phototype CABINETS**

10 POINT

16A 24a \$3 10

**IMPRUDENT Midshipmen**

8 POINT

20A 30a \$3 00

**Refined Gaskin**

**TEARQUICK**

1 2 3 4 5

6 POINT

25A 35a \$3 00

**Bargain Pursuers**

**INDUSTRIOUS**

1 2 3 4 5

**GOTHIC WIDE**

11

36 POINT No. 1

5A \$6 30

**SINBAD**

30 POINT No. 1

5A \$4 55

**CONICAL**

24 POINT No. 1

6A \$3 85

**SOUTHERN**

20 POINT No. 1

10A \$3 80

**FARM LANDS**

16 POINT No. 1

8A \$2 45

**THE OLD PATH**

12 POINT No. 1

12A \$2 30

**4 OLD DOG TRAY**

10 POINT No. 1

14A \$1 80

**MISSOURI FARMER 8**

8 POINT No. 1

16A \$1 70

**79 LARGEST STEAMBOAT**

6 POINT No. 1

22A \$2 55

**PLEASANT SUMMER RETREAT 52**

6 POINT No. 3

35A \$2 35

**MODEL SAFES 79**

6 POINT No. 4

35A \$2 05

**LARGE BOAT RACE 2**

6 POINT No. 5

35A \$2 00

**HOPE NOW BLASTED 8**

6 POINT No. 6

35A \$2 00

**4 RUTHLESS HAND OF TIME**

**GOTHIC WIDE No. 2**

24 POINT

5A 7a \$5 60

**BOAT Lines**

20 POINT

6A 10a \$4 95

**Snow 5 BIRD**

16 POINT

8A 12a \$4 20

**Eastern Custom  
FASHION**

12 POINT

12A 18a \$4 15

**European Nations  
CONGRESS**

10 POINT

14A 20a \$3 15

**28 Powerful Machines  
REPAIR SHOPS**

8 POINT

16A 28a \$3 20

**Rules for Measurement 49  
VERY SUCCESSFUL**

6 POINT

22A 32a \$3 05

**35 Founded by Small Subscription  
PUBLIC LAW LIBRARY**

**GOTHIC SLOPE No. 20**

22 POINT

10A 22a \$3 50

*Chinese Garden 29 Production*  
**WHEAT AND BARLEY**

18 POINT

14A 32a \$3 25

*Siberian Monarch 87 Delivers Oration*  
**AMBITION LEADS DISCRETION**

12 POINT

20A 40a \$3 00

*Romantic Literature 615 Bought in London Markets*  
**IMPORTANT ACQUISITION TO LIBRARY**

10 POINT

22A 50a \$2 75

*Some Ancient Manuscripts and 20 Parchments Received*  
**ELEGANTLY BOUND IN MOROCCO LEATHER**

8 POINT

28A 56a \$2 50

*Designed to Furnish Pastime and 34 Amusement for School Children*  
*Robinson Crusoe and Several Bright Stories*  
**INTERESTING SAYINGS REPEATED AMONG COMPANY**

6 POINT

30A 60a \$2 25

*Remarkable Stories Related by 36 Rescued Shipwrecked Mariners from Cannibals*  
*Additional Magnificent Specimens of Ocean Steamships*  
**WONDERFUL PICTURESQUE AMERICAN MOUNTAIN SCENERY**

**GOTHIC ITALIC No. 124**

12

24 POINT

10A 20a \$3 20

10A \$1 15

*Orations ENGRAVED EMPHATIC*

18 POINT

12A 24a \$2 95

12A \$0 95

*62 Moderation EDUCATED MONITORS*

12 POINT

18A 36a \$2 55

18A \$0 90

*Brandishing Weapons Moderately Displaying*

*BEAUTIFUL 45 AUTOGRAPHS*

10 POINT

24A 48a \$2 65

24A \$0 85

*Beautiful Entertainments for Collegiate Advantages*

*HERE HONORABLE 4368 OCCUPATIONS SELECT*

8 POINT

24A 48a \$2 20

24A \$0 70

*Artistic Conversationalists Ignored Parliamentary Struggles*

*ORGANIZING UNANIMOUSLY*

*FREEBOOTERS GYMNASIUMS INCLUDING COEDUCATES*

6 POINT

32A 64a \$2 25

32A \$0 75

*Unconsciously Bestowing Blessings Upon Heavens Chosen People Worshipped*

*UNGATHERED SALVAGES FROM SUBMARINE*

*SUBSEQUENT PILFERINGS RESTORED THROUGH CHARITY GREAT 54*

5 POINT ON 6 POINT

32A 64a \$1 95

32A \$0 85

*Historical Works of Josephus Gaining Popular Recognition During the Caesarian Dynasties*

*MONARCHIAL CELEBRATIONS FERMENTING DISCORD*

*DELETERIOUS ENTERPRISES FOMENT MUTUAL HEREDITARY DISAGREEMENTS*

SMALL CAPS NOT SENT UNLESS EXPRESSLY ORDERED.

COMBINATION ITALIC GOTHIC

48 POINT No. 150

4A \$4 00

***PROVIDE 15***

36 POINT No. 149

6A \$3 40

***HOME 4 RULES***

24 POINT No. 138

8A \$2 50

***23 GENERAL CARGO***

24 POINT No. 137

10A \$2 25

***ENGRAVED 6 THOUGHT***

18 POINT No. 136

14A \$2 00

***PHILOSOPHIC STIMULANTS 79***

12 POINT No. 135

16A \$1 40

***REPRESENTED BUILDING MATERIAL 86***

12 POINT No. 134      20A \$1 40

***LATEST CATALOGUE 5  
FOR DELIVERY***

12 POINT No. 133      24A \$1 40

***14 JOB PRINTING PRESSES  
SECOND-HAND ROOM***

6 POINT No. 132      30A \$1 35

***87 SUPERIOR PLATES FROM  
IMPROVED MACHINE***

6 POINT No. 131      40A \$1 35

***NOBLE PATRIOTS 875 LONG DEPARTED  
UNITED STATES OF AMERICA***

ALL SIZES LINE TOGETHER AT THE BOTTOM

**Gothic Italic Extra Condensed**

15

42 POINT

8A 10a \$7 00

*BEAUTIFUL PAINTINGS*  
*Admire Noble Endeavor*

36 POINT

9A 12a \$6 00

*ENTERPRISING MUSICIANS*  
*Numerous Selections Given*

30 POINT

10A 14a \$5 00

*ORIENTAL MANNERS OR CUSTOMS*  
*Heavy Importers 63 Prize Woolen*

24 POINT

12A 16a \$4 25

*GENIUS OF RICHELIEU AND MAZARIN*  
*Developing Greatest Executive Ability*



**Gothic Italic Extra Condensed**

15

20 POINT

15A 20a \$4 00

*COURTLY AND UNBOUNDED EXTRAVAGANCE  
Madame de Pompadour's Expense Account*

16 POINT

18A 24a \$3 75

*FRIVOLOUS AND PLEASURE-SEEKING TRAVELERS  
Excursions Direct to the Cumberland Mountains*

12 POINT

20A 30a \$3 40

*FALL OF NAPOLEON AS A LESSON TO FUTURE TYRANTS  
Manners and Morals to be Pondered Over for Eternity*

10 POINT

24A 36a \$3 25

*GREAT BARGAINS IN BATH WRAPPERS FOR LADIES AND MEN  
Convince Yourself That These are the Very Finest Goods Made*

8 POINT

26A 38a \$3 00

*THOSE WHO HAVE LABORED WELL LOVE THE COMING OF THE NIGHT TIME  
Rest Always Being a Condition Much More Blessed to Them than to Idlers*

6 POINT

28A 40a \$2 50

*MUCH DISCONTENT AND CHAGRIN ALWAYS FOUND IN THE UNION OF MAY WITH DECEMBER  
She Accepted Him Solely for His Name and Rank, and He Married Her Only for Her Beauty*

**GOTHIC ITALIC**

11-12

60 POINT NO. 123

3A 6a \$9 60

*HER Man*

48 POINT NO. 123

4A 8a \$7 80

*MICE Come*

36 POINT NO. 123

5A 10a \$6 40

*Craves Bonus*  
**REUNIONS**

30 POINT NO. 112

10A 14a \$4 50

*Roast Turkey Gobbler*  
**THANKSGIVING**

11  
**GOTHIC ITALIC**

20 POINT NO. 112

18A 24a \$3 65

*Drying Up a Single Tear Has*  
**MORE MERIT 53**

18 POINT NO. 112

18A 25a \$2 80

*Youth and Wisdom Were Not Combined*  
**DECORUM LIMPS BEHIND**

12 POINT NO. 112

22A 38a \$2 50

*How Peaceful and Powerful is the Quiet Grave*  
*Which Hushes Worldly Strife*  
**SLEEP WHICH KNOWS NO WAKING**

10 POINT NO. 112

30A 42a \$2 60

*Don't use Big Words in Promulgating Useless Esoteric*  
*Cogitations or Articulating Superficial*  
**AND RAMBLING EXPRESSIONS OF SPEECH**

8 POINT NO. 112

36A 52a \$2 60

*When Athens' Armies Fell and Fettered Thousands Bore the Yoke*  
*of War at Syracuse, then Redemption*  
**ROSE UP IN THE ATTIC MUSE AND CONQUERED**

6 POINT NO. 113

30A 60a \$2 40

*'Tis Sweet to Hear the Watch Dog's Honest Bark bay Deep-Mouthed*  
*Welcome as we Draw near Home, 'tis Sweet to*  
**SEE THE OLD FAMILIAR OBJECTS AS THE DAY COMES**

**DORIC ITALIC**

60 POINT

4A 5a \$15 50

***9 Rain***  
**BEAM**

48 POINT

4A 5a \$10 75

***North 5***  
**POINTS**

36 POINT

5A 7a \$8 75

***7 Matured***  
**BAD PLOT**

**DORIC ITALIC**

30 POINT

5A 7a \$6 50

***Gun 19 Boats  
BIRD SHOT***

24 POINT

6A 10a \$5 00

***\$12 Coast Defence  
FRENCH NATION***

18 POINT

8A 12a \$4 50

***American 39 Republic  
PRESIDENT-ELECT***

12 POINT

10A 20a \$4 25

***Glorious Melodies Inspire 287  
QUOTATION FOR LITERATI***

10 POINT

12A 25a \$4 00

***£93 Government Officials Nominated  
HAUGHTY SPANIARDS VAGATE***

8 POINT

15A 30a \$3 75

***Grand Music Interspersed by Intervals 16  
SEVERAL BEAUTIFUL NOTES PROLONGED***

6 POINT

18A 40a \$3 50

***Dignifies Religious Ceremonies, and Educates £1234  
MUSIC IS THAT MODEL OF DIVINE ELEGANCE***

**INCLINED GOTHIC**

24 POINT

8A \$3 00

**SAD 2 BOY**

18 POINT

12A \$2 50

**TURN 43 HALL**

16 POINT

14A \$2 25

**SOUTH 56 GUARD  
BALTIMORE**

12 POINT

20A \$2 00

**CYCLE PRESS CLUB 31  
LIFE IN NEW YORK**

10 POINT

24A \$1 75

**OUR NOBLE SHIPS STEM 79  
THE RIO GRANDE**

8 POINT

26A \$1 50

**KNIGHTS TEMPLARS PARADED 1895  
THROUGH BOSTON STREETS**

6 POINT NO. 7

28A \$1 25

**ITALIAN OPERA AT MECHANICS BUILDING 23  
EXCURSIONS TO EUROPE**

6 POINT NO. 6

30A \$1 25

**39 HUNDRED THOUSAND EXCURSIONISTS WENT  
FINE EMBROIDERY MATERIALS EXHIBITED**

6 POINT NO. 5

32A \$1 25

**INVENTIONS DISPLAYED 86  
MISCELLANEOUS**

6 POINT NO. 4

34A \$1 25

**FASHIONABLE 90 LOCATIONS  
COMMONWEALTH**

QUENTELL SERIES

15

72 POINT

4A 5a \$17 00

**BIG Run**

60 POINT

4A 5a \$12 25

**GRINDER  
Blotch**

54 POINT

4A 5a \$10 25

**MIRACLES  
Endured**

QUENTELL SERIES

48 POINT

4A 5a \$7 75

**HOME Road**

42 POINT

4A 6a \$7 25

**BORN GREAT  
Stop Thief**

36 POINT

5A 8a \$5 50

**NOBLE ANTONY  
Races Home**

30 POINT

6A 9a \$5 00

**AUGUST RAMBLES  
Evening Hour**



**QUENTELL SERIES**

15

24 POINT

8A 10a \$4 00

**RECORD DISPOSITIONS**  
**Undisputed Claims**

18 POINT

10A 16a \$3 25

**FRUIT RAISERS' ASSOCIATION**  
**Exhibiting Productions**

14 POINT

12A 18a \$3 25

**PICKING BEAUTIFUL WHITE FLOWERS**  
**During Short Holiday Seasons**

12 POINT

16A 20a \$3 00

**ALWAYS RECOMMEND SUPERIOR QUALITIES**  
**Prices That Defy Competition**

10 POINT

20A 26a \$2 75

**PROSPECTIVE BUYER ASSURED COURTEOUS TREATMENT**  
**Strategetic Real Estate Dealers Have Success**

8 POINT

22A 30a \$2 50

**JUDICIOUS ADVERTISING HAS IMPROVED RAILROAD BUSINESS**  
**Vestibuled Trains Between Keokuk and Rochelle**

6 POINT

24A 36a \$2 25

**BENEVOLENT CHRISTIAN GENTLEMEN PROPOSE BUILDING CHARITABLE HOMES**  
**Plans and Specifications Cheerfully Furnished on Application**

DE VINNE EXTENDED

48 POINT

3A 4a \$11 50

FAWN  
Case

42 POINT

4A 5a \$10 00

HOUSE  
Broke

36 POINT

4A 6a \$8 00

RECORD  
Makers

30 POINT

5A 8a \$7 00

MODESTY  
Shocked

DE VINNE EXTENDED

15

24 POINT

6A 10a \$6 00

**DENOUNCED**  
**Respecting**

18 POINT

9A 12a \$4 50

**GREAT ORATORS**  
**Fine Speech**

14 POINT

10A 14a \$3 75

**EASTERN CLIMATE**  
**Childhood Scenes**

12 POINT

14A 18a \$3 50

**TEMPERANCE MEETING**  
**Thursday Night 8**

10 POINT

18A 24a \$3 00

**COMMISSION TO MERCHANTS**  
**Payment Promptly Made**

8 POINT

22A 30a \$2 75

**SUMMER ROSES QUICKLY FADE**  
**Caledonian Club Associations**

6 POINT

24A 36a \$2 50

**OBSERVATION TAKEN AFTER SUNDOWN**  
**Valuable Astronomical Calculations**  
**1 2 3 4 5 6 7 8 9 0**

DE VINNE SERIES

15

72 POINT

4A 5a \$17 00

Finest

60 POINT

4A 5a \$12 25

SONGS

Robin

54 POINT

4A 5a \$10 25

FRIGHT

Mantel

DE VINNE SERIES

15

48 POINT

4A 5a \$7 75

**DREAMS**  
**Leader**

42 POINT

4A 6a \$7 25

**PRINCESS**  
**Station**

36 POINT

5A 8a \$5 50

**GOLD MINE**  
**Corporate**

30 POINT

6A 9a \$5 00

**FINE OPINION**  
**Contractor**

DE VINNE SERIES

24 POINT

8A 10a \$4 00

**BUILDING STONE**  
**Strange Design**

18 POINT

10A 16a \$3 25

**NUMEROUS REQUESTS**  
**Severe Customer**

14 POINT

12A 18a \$3 25

**COLUMBIA BRICK COMPANY**  
**Handsomely Dressed Girls**

12 POINT

16A 20a \$3 00

**FIFTH BEAUTIFUL ILLUMINATION**  
**Myriads of Electric Lights**

10 POINT

20A 26a \$2 75

**MAKES DIRECT TELEGRAPHIC CONNECTION**  
**Descriptive Accounts of South America**

8 POINT

22A 30a \$2 50

**ANNUAL PROMISES OF USUAL LARGE DIVIDEND**  
**Hardships Encountered by Early Settler**

7 POINT

22A 34a \$2 50

**HARVESTING MACHINERY BROUGHT VERY LOW PRICES**  
**Farmers and Merchants Much Gratified by Good Crop**

6 POINT

24A 36a \$2 25

**NATIONAL METER COMPANY**  
**Tenth Annual Report 85**

5½ POINT

24A 36a \$2 50

**HANDSOME BRONZE DISPLAY**  
**Antiquated Ornaments 34**

DE VINNE CONDENSED

15

72 POINT

4A 5a \$15 00

RIG List

60 POINT

4A 5a \$10 00

BINDERS  
Drama

54 POINT

4A 5a \$7 50

STUDENT  
Honesty

DE VINNE CONDENSED

15

48 POINT

4A 5a \$6 00

ROMANTIC  
Maidens

42 POINT

4A 6a \$5 50

COAL MINES  
Excavating

36 POINT

5A 8a \$5 00

FRENCH BOND  
Judgments

30 POINT

6A 9a \$4 50

FLEETING HOURS  
Smiles of Hope



DE VINNE CONDENSED

15

24 POINT

8A 12a \$4 00

**FLOWERS OF WINTER**  
**Music of Philosophy**

18 POINT

10A 16a \$3 25

**BUILD MOUNTAIN BASTIONS**  
**Production of Labor**

14 POINT

12A 20a \$3 25

**RARE EXCELLENCE OF GIRLHOOD**  
**Freshness of Eternal Youth**

12 POINT

18A 22a \$3 00

**SALE OF ANCIENT AND MODERN PICTURES**  
**Where Women are Considered Comely**

10 POINT

22A 30a \$2 75

**GATHER RICH HARVEST OF NORTH AMERICAN FLORA**  
**Biographical Inquiry Concerning Rome**

8 POINT

25A 36a \$2 50

**THRIFT OF TIME WILL GREATLY REPAY YOU IN AFTER LIFE**  
**With a Profit Beyond Your Most Sanguine Dreams**

6 POINT

30A 42a \$2 25

**POLITICS AND VERACITY HAVE THE SAME NUMBER OF LETTERS BUT THAT**  
**Is all They Have in Common, There the Resemblance Ends**

DE VINNE EXTRA CONDENSED

72 POINT

4A 5a \$15 00

Read Page

60 POINT

4A 5a \$9 00

Houses Built  
RICH STONE

54 POINT

5A 7a \$8 00

Fancy Dress 5  
SHOE MAKER

**DE VINNE EXTRA CONDENSED**

15

48 POINT

5A 8a \$7 00

**Breech Loading  
SUNDRY NOTES**

42 POINT

6A 10a \$6 00

**Regular Elections  
TOWNSHIP VOTE**

36 POINT

6A 12a \$5 50

**Model Advertisements  
EXTENSIVE DISPLAY**

DE VINNE EXTRA CONDENSED

15

30 POINT

8A 12a \$5 00

**German Railroad Company  
RECENT IMPROVEMENTS**

24 POINT

10A 16a \$4 00

**Reduction in First Cabin Rates 7  
SPANISH STEAMSHIP COMPANY**

18 POINT

12A 20a \$3 25

**Annual Display of Manufactured Goods  
ST. LOUIS EXPOSITION AND MUSIC HALL**

14 POINT

18A 22a \$3 25

**Fall of Napoleon as a Lesson to Future Tyrants  
EXHIBIT OF ANCIENT AND MODERN PICTURES**

12 POINT

20A 26a \$3 00

**The Smallest Man was Chemah, a Chinese Dwarf, 25 inches  
STRONGEST FORTRESS IN THE WORLD IS GIBRALTAR**

DE VINNE ITALIC

15

72 POINT

4A 5a \$19 00

*Hands*

60 POINT

4A 5a \$13 25

*MISER*  
*Exact*

54 POINT

4A 5a \$11 25

*JULIUS*  
*Outing*

DE VINNE ITALIC

15

48 POINT

4A 5a \$7 75

*READER*  
*Cramps*

42 POINT

4A 6a \$7 25

*BOULDER*  
*Granite*

36 POINT

5A 8a \$6 50

*FINE BANK*  
*Depositors*

30 POINT

6A 9a \$5 75

*THIRD HOUSE*  
*Old Soldier*

DE VINNE ITALIC

15

24 POINT

8A 10a \$4 50

***BUSINESS FIRMS***  
***Common Sense***

18 POINT

10A 16a \$4 00

***PROSPEROUS FARMER***  
***Special Harvest***

14 POINT

12A 18a \$3 25

***SYSTEMS OF PENMANSHIP***  
***Muscular Movement 62***

12 POINT

16A 20a \$3 00

***RIGHT OF FOREIGN CORPORATION***  
***Concentrate Your Forces***

10 POINT

20A 26a \$2 75

***CONSIDER IMPORTANT BANKING QUESTION***  
***Percentages of the Total Subscriptions***

8 POINT

22A 30a \$2 50

***BIOGRAPHIES OF MANY DISTINGUISHED PEOPLE***  
***Revised Encyclopedia for all Americans***

6 POINT

24A 36a \$2 25

***THE HEART BECOMES HEROIC BY THE MIGHT OF PASSIONS***  
***True Love is the Salutation of the Angels to the Stars***

DE VINNE ITALIC OUTLINE

15

72 POINT

4A 5a \$17 00

*Hands*

60 POINT

4A 5a \$12 25

*Reason*

54 POINT

4A 5a \$10 25

*NO Silk*

48 POINT

4A 5a \$7 75

*BIG King*

42 POINT

4A 6a \$7 25

*OLD Grain*



DE VINNE ITALIC OUTLINE

15

36 POINT

5A 8a \$6 50

*FINE Depots*

30 POINT

6A 9a \$5 75

*THIRD Soldier*

24 POINT

8A 10a \$4 50

*BUSINESS FIRMS  
Common Sense*

18 POINT

10A 16a \$4 00

*PROSPEROUS FARMER  
Special Harvest*

14 POINT

12A 18a \$3 25

*SYSTEMS OF PENMANSHIP  
Muscular Movement 72*

12 POINT

16A 20a \$3 00

*RIGHT OF FOREIGN CORPORATION  
Concentrate Your Forces*

DE VINNE SHADED

72 POINT

4A 5a \$17 00

Niles 5

60 POINT

4A 5a \$12 50

2 PENS

54 POINT

4A 5a \$10 50

Zebras 6

48 POINT

4A 5a \$7 75

TRUMPS

Present 4

DE VINNE SHADED

42 POINT

4A 6a \$7 50

Seminole 5  
MINISTER

36 POINT

5A 8a \$5 75

Night 9 Bard  
LEMONADE

24 POINT

8A 10a \$4 50

Honestly 38 Spoken  
MEXICAN DOCTOR

18 POINT

10A 16a \$3 75

Governors 21 Body Guard  
PUBLIC SOLDIER

12 POINT

16A 20a \$3 25

Gorgeous Uniforms \$20 and Artillery  
REVIEWING STATE MILITIA

HOWLAND SERIES

60 POINT

4A 5a \$9 00

DUE 5 Cart

54 POINT

4A 6a \$8 00

FINE Much 8

48 POINT

5A 8a \$7 00

Friend 23 John  
NOBLE NAMES

42 POINT

6A 10a \$6 00

Burned Naphtha \$5  
ENGLISH POETRY

THE HOWLAND AND HOWLAND OPEN SERIES MAKE A FINE EFFECT WHEN ONE IS PRINTED OVER THE OTHER IN DIFFERENT TINTS

**HOWLAND SERIES**

30 POINT

8A 12a \$5 00

**Beautiful 26 Painter  
MEXICAN FARMERS**

24 POINT

10A 16a \$4 00

**Ridiculous 57 Performing  
CHEAP ATHLETIC TRADE**

18 POINT

12A 20a \$3 25

**Spanish Guitars 90 Musical Cadence  
PRINCE EDWARDS ISLAND**

12 POINT

20A 30a \$3 00

**Vermont Farmers 91 Smothered Ambition  
MIDNIGHT SERENADER CRUSHED**

10 POINT

24A 36a \$2 75

**Carried the Deceased 78 Reuben to Town Cemetery  
JONATHAN SIMPSON'S BLACK HORSE**

8 POINT

28A 40a \$2 50

**Trials and 910 Tribulations  
NUMEROUS MOURNERS**

6 POINT

30A 50a \$2 25

**Welcome News for 46 Deacons  
VERY STORMY MARCH**

THE HOWLAND AND HOWLAND OPEN SERIES MAKE A FINE EFFECT WHEN ONE IS PRINTED OVER THE OTHER IN DIFFERENT TINTS.

HOWLAND OPEN

60 POINT

4A 5a \$9 50

DUE 4 BOYS

54 POINT

4A 6a \$8 50

FINE Home 8

48 POINT

5A 8a \$7 50

Latest 2 Record  
NOBLE HORSE

42 POINT

6A 10a \$6 50

Burned Naphtha \$5  
ENGLISH POETRY

THE HOWLAND OPEN AND HOWLAND SERIES MAKE A FINE EFFECT WHEN ONE IS PRINTED OVER THE OTHER IN DIFFERENT TINTS.

HOWLAND OPEN

30 POINT

8A 12a \$5 50

Beautiful 26 Painter  
HISTORIC MONSTER

24 POINT

10A 16a \$4 50

Ridiculous 57 Performing  
CHEAP ATHLETIC TRADE

18 POINT

12A 20a \$3 50

Spanish Guitars 90 Musical Cadence  
BEAUTIFUL HARMONY PRESENTED

12 POINT

20A 30a \$3 00

Vermont Farmers 81 Smothered Ambition  
Great Sympathy Expressed  
MIDNIGHT SERENADERS CRUSHED

10 POINT

24A 36a \$2 75

Carried the Deceased 79 Reuben to Town Cemetery  
Mourners Trials and Tribulations  
JONATHAN SIMPSON'S BLACK HORSE

THE HOWLAND OPEN AND HOWLAND SERIES MAKE A FINE EFFECT WHEN ONE IS PRINTED OVER THE OTHER IN DIFFERENT TINTS

**COLUMBUS  
OUTLINE  
INITIALS**

PRICE PER FONT

36 POINT . \$2 00

48 POINT . 3 00

60 POINT . 4 00

FONTS CONTAIN ONLY THE  
12 INITIALS SHOWN

B

C

E

F

K

L

**COLUMBUS OUTLINE**

60 POINT

3A 4a \$12 35

Risk

NO

18 POINT WITH 36 POINT INITIAL

HUM Tunes

48 POINT

3A 5a \$9 35

Enter

BIN

THE COLUMBUS OUTLINE WILL REGISTER WITH THE COLUMBUS NO. 2



**COLUMBUS OUTLINE**

36 POINT

5A 8a \$8 00

Grants

SIX

24 POINT

10A 15a \$7 05

Examiner

RICH

67890

18 POINT

15A 20a \$6 10

Mausoleums

NOTED

1234

**COLUMBUS  
OUTLINE  
INITIALS**

PRICE PER FONT

36 POINT . \$2 00

48 POINT . 3 00

60 POINT . 4 00

FONTS CONTAIN ONLY THE  
12 INITIALS SHOWN

Q

R

S

T

V

W

THE COLUMBUS OUTLINE WILL REGISTER WITH THE COLUMBUS NO. 2

**COLUMBUS  
INITIALS**

PRICE PER FONT

36 POINT . \$2 00

48 POINT . . 3 00

60 POINT . . 4 00

FONTS CONTAIN ONLY THE  
12 INITIALS SHOWN

B  
C  
E  
F  
K  
L

**COLUMBUS No. 2**

60 POINT

3A 4a \$12 35

Risk

NO

18 POINT WITH 36 POINT INITIAL

HUM Tunes

48 POINT

3A 5a \$9 35

Enter  
BIN

THE COLUMBUS NO. 2 WILL REGISTER WITH THE COLUMBUS OUTLINE

**COLUMBUS No. 2**

36 POINT

5A 8a \$8 00

**Grants  
SIX**

24 POINT

10A 15a \$7 05

**Examiner  
RICH  
67890**

18 POINT

15A 20a \$6 10

**Mausoleums  
NOTED  
1234**

**COLUMBUS  
INITIALS**

PRICE PER FONT

36 POINT	\$2 00
48 POINT	3 00
60 POINT	4 00

FFONTS CONTAIN ONLY THE  
12 INITIALS SHOWN

**Q  
R  
S  
T  
V  
W**

THE COLUMBUS NO. 2 WILL REGISTER WITH THE COLUMBUS OUTLINE

**COLUMBUS No. 2**

---

15 POINT

18A 25a \$5 00

**Daring Burglar Captured  
Not Missing  
CAUSED WONDER**

12 POINT

25A 35a \$4 25

**Handsome Brushwork Exhibition  
Framed with  
BEAUTIFUL PICTURES**

10 POINT

26A 40a \$3 75

**Electrical Appliances Used Extensively  
Pronounced Successful  
THEATRICAL ENTERPRISE**

8 POINT

30A 45a \$3 50

**Celebrated Instructors in Oil and Crayon Work  
Scholars Furnish Brushes  
WALKAROUND AND DONOTHING**

6 POINT

35A 50a \$3 25

**Amusing Pictures Illustrating Marriage Tribulations  
Come Early and Avoid the Rush  
STEREOPTICON ENTERTAINMENTS  
1234567890**

RIMPLED SERIES

48 POINT

4A 6a \$7 00

**BAR Signs**

36 POINT

5A 8a \$5 00

**Safety AGENT**

30 POINT

6A 9a \$4 25

**FAMILY Package**

24 POINT

8A 12a \$3 50

**Amusing ORATION**

18 POINT

12A 18a \$3 25

**BLITHESOME Questioners**

12 POINT

20A 30a \$3 00

**Nature's Remedy SOLD IN BOXES**

10 POINT

22A 35a \$2 75

**CRACKED VOICES Speedily Counteracted**

8 POINT

25A 40a \$2 50

**Immediate Relief after Using BROKEN HEARTS**

EASTMAN SERIES

15

72 POINT

3A 5a \$10 65

Roman

60 POINT

4A 5a \$9 90

Emotion

48 POINT

4A 6a \$6 95

MEN Rise

36 POINT

5A 8a \$5 50

HOME Boys

30 POINT

6A 9a \$5 00

Multum in Parvo  
NORFOLK

EASTMAN SERIES

15

24 POINT

8A 10a \$4 00

**Emancipation Echoes**  
**ABE LINCOLN**

18 POINT

10A 16a \$3 25

**Elevated Railway Depot**  
**RAPID TRAINS**

12 POINT

16A 20a \$3 00

**The Ideal Power for Tired Printers**  
**HERCULES GAS ENGINE**

10 POINT

20A 26a \$2 75

**California Contribution to Wonder World**  
**THE YOSEMITE VALLEY**

9 POINT

20A 40a \$2 55

**Chinese and Japanese Contestants in the Ring**  
**THE COREAN IMBROGLIO**

8 POINT

22A 30a \$2 50

**Better half a year of Europe than a cycle of Cathay**  
**LILIUOKALANI, THE FORSAKEN**

6 POINT

24A 48a \$2 30

**Revised Edition of Longfellow's Poems Beautifully Bound**  
**STUDIOUS PROFESSORS OF THE ARTS DIVINE**

LIPPINCOTT SERIES

---

60 POINT

4A 6a \$9 00

Music Box  
TUNES

48 POINT

4A 7a \$6 50

Brave Count  
HONORS

38 POINT

6A 8a \$5 00

Seaside Resorts  
ROMANTIC



LIPPINCOTT SERIES

30 POINT

7A 10a \$4 25

**Scientific Measure  
MEDITATION**

24 POINT

10A 15a \$3 75

**Dedication Ceremonies  
INAUGURATION**

18 POINT

12A 18a \$3 25

**Historical Oration Delivered  
EMINENT SENATOR**

12 POINT

22A 35a \$3 00

**Lucrative Government Positions Secured  
HONEST CITIZEN REPORTS**

10 POINT

28A 40a \$2 75

**Attaching Signatures to Important Documents  
ENCOURAGING MODERN DIPLOMACY**

8 POINT

30A 50a \$2 50

**Humane Protective Society  
CHARTER GRANTED**

1 2 3 4 5 6 7 8 9 0

6 POINT

35A 52a \$2 25

**Renowned Statesmen Deliberate  
ENTHUSIASTIC DEBATORS**

1 2 3 4 5 6 7 8 9 0

AMERICAN OLD STYLE

12

48 POINT

4A \$4 00

**DUKEDOM**

36 POINT

6A \$3 00

**HUNT 6 DUCK**

30 POINT

8A \$2 75

**28 LIME FRUIT**

24 POINT

10A \$2 50

**MONIES COINED 85**

18 POINT

12A \$2 25

**43 BLUSHES MAKE YOUTH**

12 POINT

15A \$2 00

**NOTED AMERICAN LADY PEDESTRIAN 27**

AMERICAN OLD STYLE No. 3

60 POINT

3A 6a \$10 00

**NICE List**

48 POINT

4A 8a \$7 00

**MOST Forms**

36 POINT

6A 10a \$5 50

**QUICK Returns**

30 POINT

8A 12a \$4 70

**ENGLISH Republics**

24 POINT

10A 15a \$4 00

**Striking Machine Operators  
BOSTON RECRUITS**

18 POINT

12A 18a \$3 50

**American Contractors Building Railroads  
LIBERAL DELEGATE LOCATED**

CASLON CONDENSED

12

60 POINT

3A 5a \$9 00

**BRIGHTens**

48 POINT

3A 5a \$5 50

**SEND 3 Back**

36 POINT

4A 8a \$5 00

**HOMES Received**

30 POINT

5A 10a \$4 50

**BROKEN 2 Mansions**

24 POINT

6A 12a \$3 50

**Wonderstricken Countenance  
EXPECTS COMRADE**

18 POINT

8A 16a \$3 00

**Contemplated Manufacturing Fireworks  
BOUGHT REFRESHED DESIGNS**

SAMOA SERIES

48 POINT

3A 5a \$6 50

BUN Wins

36 POINT

4A 6a \$5 00

CARE Noted

24 POINT

8A 10a \$4 00

HONEST BROTHER  
Stained Clothes 45

18 POINT

11A 16a \$3 25

NOVELTY CELEBRATING  
Doctors Prescriptions 24

12 POINT

25A 32a \$3 00

AMERICAN MINES CONSOLIDATING  
Confirmed Unitarians Dumfounded 79

The and Co

QUAINT ROMAN No. 2

48 POINT

4A 5a \$11 00

GO East

36 POINT

4A 6a \$8 50

Farm SOIL

24 POINT

6A 8a \$5 00

CHURCH CHOIR  
Ocean Travel

18 POINT

8A 10a \$4 50

ARTISTIC PICTURE  
Domestic Work

12 POINT

14A 16a \$3 25

LITERARY ENTERTAINMENT  
Antiquarian Among Books

10 POINT

14A 18a \$3 00

RARE FLOWERS OF THE MOUNTAINS  
Book About Fruit Gardens

QUAINT GOTHIC

48 POINT

5A \$5 00

**PAINTING**

36 POINT

5A \$3 50

**WIDE RIVER**

24 POINT

8A \$3 00

**AMBITIOUS BOYS  
EXCELSIOR 5**

18 POINT

10A \$2 50

**POLITICIANS PROMISE  
MANY THINGS \$523**

12 POINT

12A \$1 50

**COMMENDABLE PROMPTITUDE  
EXACTLY ON TIME \$428**

10 POINT

16A \$1 25

**PRAISEWORTHY POLAR EXPLORERS  
GREAT PERILS THEY ENDURE 7**

MORTISED SERIES

48 POINT

3A \$5 70

CHAINS

MORTISED SERIES SHOWN IN COMBINATION.

FIRST ENSIGN

Q P Q T

F L

FINE COUGH LOZENGE

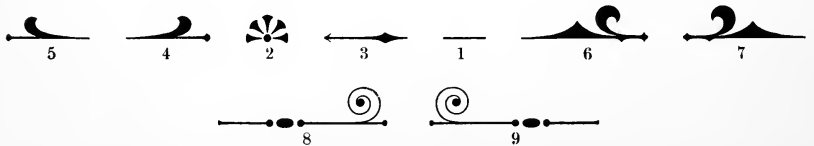

THE LETTERS C E F L Q AND T ARE MADE EACH IN TWO DISTINCT WIDTHS.



**MORTISED SERIES**

---

36 POINT

5A \$4 30

**WATCHES**

24 POINT

9A \$3 00

**REMEMBERED**

18 POINT

12A \$2 50

**FARMER INSURED**

12 POINT

18A \$2 10

**BEAUTIFUL HOMESTEAD  
RUSTIC SCENERY**

9 POINT

22A \$1 80

**SLAUGHTER WHITE ELEPHANTS  
DEXTEROUS RECRUITS**

6 POINT

25A \$1 45

**TINKETTLE DECORATIONS INSULTED CANINE  
1 2 3 4 5 6 7 8 9 0  
HOLDING INDIGNATION MEETING**

**Erratick and Erratick Outline**

48 POINT .

4A 5a \$7 50

Row Dear  
HURT

42 POINT

4A 6a \$6 00

Pun 67 Ban  
CAGE

30 POINT

6A 8a \$5 50

Good 84 Sand  
MALDEN

PRICES ARE FOR A FONT OF EITHER ERRATICK OR ERRATICK OUTLINE. ERRATICK AND ERRATICK OUTLINE MAKE A FINE EFFECT WHEN ONE IS PRINTED OVER THE OTHER IN DIFFERENT TINTS.

**Erratick and Erratick Outline**

24 POINT

8A 12a \$4 00

**English 23 People**  
**HANDSOME**

18 POINT

10A 18a \$3 50

**Delightful 45 Costume**  
**COMPOSITORS**

12 POINT

14A 24a \$3 00

**When Discovered its Adaptability**  
**MASONIC TEMPLES**

10 POINT

16A 32a \$2 75

**Quickly Appreciate Attractive Designs**  
**WIDE-AWAKE ADVERTISER**

8 POINT

20A 32a \$2 50

**Erratick Series However Became Established**  
**FACULTY OF COMBATIVENESS**

6 POINT

20A 40a \$2 25

**The Prime Favorites Distanced by Dilapidated Boneyards**  
**SHEEPSHEAD BOOKMAKER SWINDLED**  
**6-\$£1234567890£\$6-**

PRICES ARE FOR A FONT OF EITHER ERRATICK OR ERRATICK OUTLINE. ERRATICK AND ERRATICK OUTLINE MAKE A FINE EFFECT WHEN ONE IS PRINTED OVER THE OTHER IN DIFFERENT TINTS.

VIRILE AND VIRILE OPEN

60 POINT

4A 8a \$7 50

Great 2 Trap  
SERVANTS

48 POINT

6A 8a \$6 50

Eaten 24 Lives  
FIRE BUGS

36 POINT

6A 10a \$6 00

Counts 56 Always  
QUIET WAYS

PRICES ARE FOR A FONT OF EITHER VIRILE OR VIRILE OPEN. VIRILE AND VIRILE OPEN SERIES  
MAKE A FINE EFFECT WHEN ONE IS PRINTED OVER THE OTHER IN DIFFERENT TINTS

VIRILE AND VIRILE OPEN

30 POINT

8A 12a \$5 50

Drummer 78 Cowardly  
STOCK TAKING

24 POINT

10A 16a \$4 00

Harmonious 95 Marketmen  
EXPULSED WOODMAN

18 POINT

12A 20a \$3 50

Excellent Dinner and Fine Parade  
HIBERNIAN COMPANIES  
1234567890

12 POINT

16A 30a \$3 00

Beautiful Productions from Variegated Flowers  
COMPLETE FLORAL DECORATIONS  
\$1234567890£

PRICES ARE FOR A FONT OF EITHER VIRILE OR VIRILE OPEN. VIRILE AND VIRILE OPEN SERIES  
MAKE A FINE EFFECT WHEN ONE IS PRINTED OVER THE OTHER IN DIFFERENT TINTS



QUAINT OPEN

48 POINT

4A \$4 00

RED 2 MAN

36 POINT

6A \$3 40

HAND 54 BITE

24 POINT

8A \$2 90

STOVE AND GRATE

18 POINT

10A \$2 25

BAMBERG 61 PRINTERS

12 POINT

14A \$1 90

DEATH OF ALBERT DURER '26

10 POINT

20A \$1 90

FIRST COLORED PRINTS DEC. 1758

8 POINT

24A \$1 90

HERALD AND TIMES CO. 34 HURON AVENUE

The ornaments shown  $\triangle\triangle\triangle$  are put up with their respective sizes  $\triangle\triangle\triangle$  throughout series

All sizes line together accurately at the bottom

THE QUAINT OPEN AND QUAINT SERIES MAKE A FINE EFFECT WHEN ONE IS PRINTED OVER THE OTHER IN DIFFERENT TINTS

EPITAPH SERIES

48 POINT

3A \$6 00

**THINKER**

36 POINT

5A \$4 25

**REMAINDER**

24 POINT

7A \$3 25

**BRAVE SOLDIER  
◊ MOUNTAIN ◊**

18 POINT

9A \$2 50

**CHURCHES AND BURIALS  
◊ REMARKABLE 316 ◊**

12 POINT

14A \$2 25

**LARGE ASSORTMENT OF PLATES  
FUNERAL 568 INSCRIPTION**

THE EPITAPH AND EPITAPH OPEN SERIES MAKE A FINE EFFECT WHEN ONE IS PRINTED OVER THE OTHER IN DIFFERENT TINTS.



EPITAPH OPEN

48 POINT

3A \$6 00

REMAND  
BOATS

36 POINT

5A \$4 25

BEAN POLE  
FROST 52

24 POINT

7A \$3 25

SOCIAL CHIMER  
◇DUSTY◇  
BLIND AND SMOKE

THE EPITAPH OPEN AND EPITAPH SERIES MAKE A FINE EFFECT WHEN ONE IS PRINTED OVER THE OTHER IN DIFFERENT TINTS.

CONTOUR No. 2

12

48 POINT

3A \$4 70

MINER

36 POINT

4A \$3 30

PAVING 3

24 POINT

6A \$1 90

BRICK HOMES  
CRUSHED

18 POINT

8A \$1 65

FAVORED GRIMES  
HISTORIC  
GREAT 56 SIGN

CONTOUR No. 5

12

48 POINT

3A \$5 40

H O M E

36 POINT

4A \$4 00

M A R I N E  
S E N D

24 POINT

6A \$2 35

E U R O P E A N S  
6 5 3 2  
G R A N D E R

**CONTOUR No. 1**

12

48 POINT

4A 8a \$8 80

Measured  
WATER

36 POINT

5A 10a \$6 90

Scare Crow  
CRUMB 8

28 POINT

6A 12a \$5 15

Frozen Cream  
RECORD

CONTOUR No. 1

12

24 POINT

8A 16a \$5 00

Humane Sermon  
SUPERIOR

20 POINT

10A 20a \$5 00

Cuban Bonds Rated  
SNAKE 3 BITES

16 POINT

10A 20a \$3 45

Mexican Broncho Race  
Game Fish  
MOUNT VERNON

12 POINT

16A 32a \$3 25

Very Destructive Snow Storm  
Follow 58 Walton  
ENGLISH GENTLEMAN

**CONTOUR No. 6**

12

72 POINT

3A \$5 40

NUMBERS

60 POINT

3A \$3 75

DOMESTICS

48 POINT

4A \$3 20

BORN DOWN

40 POINT

5A \$2 70

FIRST 4 BANDS

**CONTOUR No. 6**

12

32 POINT

8A \$2 75

FAMOUS HEROES  
CONTRITION

24 POINT

12A \$2 25

ENORMOUS REHEARSAL  
GOLD 95 SHOE

18 POINT

18A \$2 10

EVENING CONCERT SATURDAY  
CELEBRATED EXCURSIONS

12 POINT

32A \$2 00

BROUGHT UNRELIABLE CIRCUMSTANTIAL  
EVIDENCE AGAINST 59  
UNIQUE HOUSEHOLD FURNITURE

**CONTOUR No. 4**

12

72 POINT

3A 5a \$11 95

Bourne

60 POINT

3A 5a \$9 45

Presume

HERD

48 POINT

4A 8a \$8 20

Monument

MORSE



**CONTOUR No. 4**

—12—

40 POINT

4A 8a \$6 00

Marie Dance

FRENCH

32 POINT

5A 10a \$4 90

Herman Custom

BRICKS 5

28 POINT

6A 12a \$4 00

Loitering Memorial

PHENOMENAL

CONTOUR No. 7

72 POINT

3A 6a \$7 85

MEAN Poster

60 POINT

3A 6a \$5 90

MOURN Horses

44 POINT

4A 8a \$4 40

MODEL 47 America

32 POINT

5A 10a \$3 35

Grand Electric Motors  
SHOWERING 65

**CONTOUR No. 3**

12

36 POINT

3A \$5 75

MIAT

23845

24 POINT

6A \$4 25

MINDS

OLD

18 POINT

6A \$2 25

BORDERS

DOG

MAKER

WASHINGTON SERIES

60 POINT

4A 5a \$15 00

HID Not

54 POINT

4A 5a \$10 50

Free RIG

48 POINT

4A 5a \$10 00

NEWTON  
Monday

42 POINT

4A 6a \$7 25

SHEARING  
Buckles

WASHINGTON SERIES

15

36 POINT

5A 8a \$6 75

**BRIGHTNESS**  
**Luminous**

30 POINT

6A 8a \$5 25

**ROYAL WOMEN**  
**Abundance 9**

24 POINT

8A 10a \$4 50

**GREAT PAINTINGS**  
**Fine Art Sales**

18 POINT

9A 13a \$3 50

**CALCULATING DAMAGE**  
**Secured Insurance 3**

12 POINT

12A 18a \$3 00

**BROKEN LANDS**  
**Nice Houses**

10 POINT

16A 22a \$2 75

**FARMER'S SHEEP**  
**Produce Buyer**

8 POINT

18A 24a \$2 50

**LITERATURE AND ART**  
**Elegant Magazines**

6 POINT

22A 32a \$2 25

**RESOLUTIONS OF CONDOLENCE**  
**Written in Flowery Style**

JEFFERSON SERIES

15

60 POINT

4A 5a \$11 00

HOT Rolls

54 POINT

4A 5a \$8 50

Gone BANK

48 POINT

4A 6a \$7 75

HARD Times

42 POINT

4A 6a \$6 25

Walks CHARM

36 POINT

5A 8a \$5 75

SUMMER Shower

30 POINT

6A 8a \$4 75

Paramount SECRETS

JEFFERSON SERIES

16

24 POINT

8A 10a \$4 50

**BIG MOUNTAIN RAILWAY**  
**Danger Signal \$5**

18 POINT

10A 14a \$3 25

**NEW FASHIONS IN LADIES CLOAKS**  
**Elegant and Beautiful \$523**

12 POINT

16A 24a \$3 00

**PROFESSORS AND TEACHERS OF TRIGONOMETRY**  
**Accurate Measuring Triangles by Student**

10 POINT

20A 28a \$2 75

**CELEBRATED CHARACTERS IN OUR AMERICAN HISTORY**  
**George Washington and Thomas Jefferson**

8 POINT

24A 32a \$2 50

**FIRST GRAND RECEPTION TENDERED TO THE ANCIENT ORDER OF LOUNGERS**  
**Special Invitation Extended to Policemen and all Other Gentlemen**

6 POINT

26A 38a \$2 25

**PRIVATE LESSONS GIVEN IN THE SCIENTIFIC ART OF BOXING BY WELL-KNOWN ATHLETIC PROFESSOR**  
**Punching and Thumping the Order of the Day at the Knock-Down Society**

LAFAYETTE SERIES

72 POINT

4A 6a \$9 50

FIRE Eaters

60 POINT

4A 6a \$7 50

Protects MINT

54 POINT

4A 6a \$7 00

ROASTED Clams

48 POINT

6A 8a \$7 00

Carpet SWEEPING

42 POINT

6A 9a \$6 25

SPLENDID Mornings



LAFAYETTE SERIES

15

36 POINT

8A 10a \$5 75

IMPORTED LOBSTERS  
Art Connoisseur

30 POINT

9A 12 \$5 00

GREAT WESTERN RAILWAY  
Through Limited Train

24 POINT

10A 14a \$4 00

RARE AND EXCELLENT PLACE  
Growing Rapidly Wealthy

18 POINT

12A 18a \$3 25

YACHT RACING THE FAVORITE PASTIME  
Magnificent Pleasure Yacht Burned

12 POINT

20A 30a \$3 00

FAMOUS WRITERS AND HISTORIANS OF SCOTLAND  
Teachings of Minds Outliving Many Races

DUERER SERIES

12

72 POINT

3A 5a \$10 00

Mourners

60 POINT

3A 6a \$9 00

SURE Home

48 POINT

3A 4a \$6 00

HOARD Hours

36 POINT

5A 7a \$4 75

Bankers 4 Wanted  
DISCHARGED

**DUERER SERIES**

---

24 POINT

8A 11a \$4 00

**Governmental Transaction  
Falsification  
RELATED NIGHTLY**

18 POINT

11A 16a \$3 25

**Augmenting Histories Manufactured  
Battalion 5 Outshown  
GLORIOUS NATIONAL VICTORY**

12 POINT

18A 24a \$3 00

**Enthusiastic Qualifications Guarantee Glorious  
Permanent Evolutions  
ERADICATION MORE COMPLETE 368**

RUBENS SERIES

72 POINT

5A 6a \$10 25

ROUGH Season

60 POINT

4A 7a \$7 50

MOCK 63 Custom

54 POINT

6A 8a \$6 75

TRUSTY 98 Friend

48 POINT

6A 8a \$6 00

SERVICES Performed

42 POINT

7A 10a \$5 50

BRIGHTER 25 Mechanics

RUBENS SERIES

36 POINT

8A 12a \$5 00

**BRIDES DESIRE Utmost Faith**

30 POINT

10A 14a \$4 50

**HARSH PERSONAL Controversy 352**

24 POINT

12A 18a \$4 25

**Annual Christmas Invitation Extended  
GENEROUS OPERA RECEPTION**

18 POINT

12A 24 \$3 25

**Mechanical Appliances Thoroughly Introduced  
678 COLUMBIA FUEL COMPANY**

12 POINT

22A 36a \$3 00

**Unfriendly Feeling Between Powerful European Nationalities  
HISTORICAL MONUMENTS DESERVE COMMENDATION**

ATLANTA SERIES

15

48 POINT

4A \$10 00

KING

42 POINT

4A \$7 25

MAIN

36 POINT

4A \$6 75

MINES  
LEAD

30 POINT

5A \$5 00

MITERS  
MUGH

ATLANTA SERIES

15

24 POINT

6A \$4 50

POWER 8  
STRONG

18 POINT

8A \$3 50

➤ SURE FIRE ➤  
PUT ⬤ OUT

14 POINT

9A \$3 25

ROMANCERS ⬤ 89  
MODELING

12 POINT

12A \$3 00

FOUNDERED ⬤ SHIPS  
➤ LOST AT SEA ➤

10 POINT

16A \$2 75

RAINING · ON · THE · ROOF  
POURING DOWN

8 POINT

20A \$2 50

COURAGEOUS ⬤ YOUNG ⬤ LADIES ⬤ 16  
SKATING ALONG ON ICE

6 POINT

28A \$2 25

INCANDESCENT ELECTRIC LIGHT AND POWER  
STREET CARS RUN AT NIGHT

VICTORIA SERIES

—15—

43 POINT

5A \$8 50

RANKS

42 POINT

6A \$7 25

➤ MILE ➤  
CHILD

36 POINT

6A \$6 75

SHEARER  
LOOKED

30 POINT

7A \$5 00

➤ LOVERS ➤  
LONGING



VICTORIA SERIES

—15—

24 POINT

8A \$4 50

LIMITED RUN  
BANKER

18 POINT

10A \$3 50

GRATIOT ❖ STREET  
❖ BOULDERS ❖

14 POINT

12A \$3 25

MODEST 89 FASHIONS  
QUIET COLOR

12 POINT

16A \$3 00

BORDERING ❖ ON ❖ INSANITY  
❖ ALMOST · A · GENIUS ❖

10 POINT

20A \$2 75

FRESH POSIES FROM THE GARDEN  
BEAUTIFUL TO BEHOLD

8 POINT

28A \$2 50

HANDSOME ❖ FACES ❖ VOLUPTUOUS ❖ FIGURES  
❖ NOVEL · AND · STARTLING · COSTUMES ❖

6 POINT

36A \$2 25

POLAR EXPEDITION LOST IN FAR NORTHERN LATITUDE AND  
SURROUNDED BY SNOW ICEBERGS

ALASKAN SERIES

12

48 POINT

3A \$7 30

DIME

HIS

36 POINT

4A \$6 00

CORDS

BEN

24 POINT

6A \$4 50

FOUNDER

SHIRK

ALASKAN SERIES

—12—

18 POINT

8A \$3 65

REPUBLICAN  
85 HORSE

12 POINT

10A \$2 05

BAND PLAYED MARCH  
KINDHEARTED  
GOLDEN MOMENTS

10 POINT

12A \$1 70

BASE COMIC OPERA TROUPE  
LOVING DESIRE  
POLITICAL 36 SCHEME

8 POINT

16A \$1 70

NEGRO BARBER SHARES DAILY BREAD  
HISTORICAL MONUMENT  
OUTING TICKETS PRINTED CHEAP

6 POINT

24A \$1 50

QUOTED SCRIPTURE THROUGHOUT INTERESTING LECTURE  
ZEALOUSLY GUARD YOUR POCKETBOOK  
DETERMINED APPEAL FROM CUBAN PATRIOT 23456

DOUGLAS SERIES

—12—

48 POINT

3A 6a \$6 25

GONSumer

42 POINT

3A 6a \$5 00

FIVE 5 Gents

36 POINT

4A 8a \$4 90

Renew GAME

30 POINT

6A 12a \$4 45

DESIGN Gostume

24 POINT

8A 16a \$4 30

HUMAN 4 Monster

18 POINT

10A 20a \$3 30

NUMEROUS Banishments

12 POINT

12A 24a \$2 10

Decorate Uniform  
SUPERBLY

10 POINT

18A 36a \$2 40

Spanish Pilots Ruined  
EXPOSED 786

LINCOLN SERIES

12

60 POINT

3A 6a \$7 25

BLUE ROSES

48 POINT

4A 9a \$6 00

NOVEL Drama

42 POINT

4A 8a \$5 00

HOUSE 4 Scene

36 POINT

5A 10a \$4 75

BRING Receipt 79

30 POINT

6A 12a \$3 75

85 EARLY Gable News

24 POINT

8A 16a \$3 50

Numerous Houses Burning

18 POINT

10A 20a \$2 75

Exceptional Advantages Granted

12 POINT

12A 24a \$2 25

Baltimore Lithograph  
COMPANY 654

10 POINT

20A 40a \$2 00

European Writers Contribute  
GREAT 786 WORKS

TYPO SERIES

60 POINT

3A 4a \$7 00

Wheat FIELD

48 POINT

4A 6a \$5 25

CLOUDY Weather

36 POINT

5A 7a \$4 70

Serpentine DANCER

30 POINT

6A 9a \$3 55

EXPORTED Productions

24 POINT

8A 10a \$2 85

Critical Surgical OPERATIONS

18 POINT

10A 14a \$2 40

VIOLENT STORMS Homes Destroy 54

MANSFIELD SERIES

12

48 POINT

3A 6a \$8 50

Grand Boats

36 POINT

4A 8a \$6 00

Spring 83 Game

24 POINT

6A 12a \$4 00

Thomas Pheline Quartette  
48 Serenaders

18 POINT

8A 16a \$3 50

Recorded With Bright Lettering  
The Commendable Deeds

12 POINT

10A 20a \$3 00

Farther We Speed the Better We Learn That  
Humanities Need 3456

FERDINAND SERIES

60 POINT

3A 5a \$9 85

Hydrangea

48 POINT

3A 8a \$7 35

Renewing  
Garden Fence

36 POINT

4A 10a \$5 30

Friendship  
Morning Chitchats  
1234567



HOUGHTON SERIES

60 POINT

3A 4a \$11 90

Monitors

48 POINT

3A 5a \$9 25

Fast Time

36 POINT

3A 7a \$7 50

Excited Critic

;) @ Hunts ) ) (

24 POINT

4A 10a \$4 50

Muscular Exercises

1 2 3 4 5 6 7 8

**McCULLAGH SERIES**

15

48 POINT

4A 7a \$6 50

**LITTLE MACK**  
**The Editor**

42 POINT

5A 8a \$6 00

**NIGHT MARTYR**  
**The Publicist**

36 POINT

6A 9a \$5 50

**ARE VERY POINTED**  
**Mack's Effusions**

McCULLAGH SERIES

15

30 POINT

7A 10a \$4 25

**AND BEST OF ALL THE  
First 5 Paragraphs**

24 POINT

8A 12a \$4 00

**THAT BRAINIEST EXPONENT  
Paper That is Printed**

18 POINT

10A 14a \$3 25

**BUT THE PAPER HE WAS RUNNING  
Made the Rusty Fossils Swear**

12 POINT

16A 20a \$3 00

**SHREWD REPORTERS SECURED DAMAGING EVIDENCE  
Unfortunate Adventurers Disappeared**

10 POINT

20A 26a \$2 75

**THE EDITORIAL ASSOCIATION MET IN CAIRO APRIL 28, 1897  
The Coming Presidential Campaign Was Aably Discussed**

IROQUOIS SERIES

15

36 POINT

3A 6a \$6 50

**SUN Dials**

30 POINT

4A 8a \$5 50

**Quick Maids  
SMILED**

24 POINT

5A 10a \$4 50

**Honest Dealer  
— CHEAP —**

18 POINT

6A 12a \$3 30

**Western Grandeur  
MOUNTAINS**

12 POINT

10A 18a \$2 40

**Native Dame  
BUXOM**

10 POINT

14A 20a \$2 35

**Musical Charm  
ENTRANCE**

8 POINT

15A 30a \$2 10

**Popular Tragedians  
ENTERTAINED  
1 2 3 4 5 6 7 8**

6 POINT

20A 40a \$2 40

**Recreation Invigorates  
TERPSICHOEAN  
1 2 3 4 5 6 7 8 9**

**IROQUOIS CONDENSED**

—15—

36 POINT

5A 8a \$4 90

**Natural Mound  
REAGHED**

30 POINT

6A 9a \$4 25

**Modern Diversion  
GRICKETER**

24 POINT

8A 12a \$3 75

**Benevolent Mechanics  
SUBSCRIPTION**

18 POINT

10A 16a \$3 00

**Choice Selections Rendered  
OPENING EXERCISES  
1 2 3 4 5 6 7 8 9 0**

TRINAL—Series One

24 POINT WITH 36 POINT INITIALS

12

6A \$3 00

INITIALS  
3A \$2 60

EIGHT MORE  
GROGER

18 POINT WITH 24 POINT INITIALS

8A \$2 85

INITIALS  
3A \$1 50

MODEST GARDEN  
⇒ 234567 ⇐  
ENTER HOMES

12 POINT WITH 18 POINT INITIALS

10A \$2 50

INITIALS  
4A \$1 15

NONE UNDER VALUE  
≡⊗≡ ⊗ ≡ ≡⊗  
A B C D E F H

TRINAL—Series Two

12

36 POINT WITH 48 POINT INITIALS

4A \$4 40

INITIALS  
3A \$5 00

HANGER  
PUNS

28 POINT WITH 36 POINT INITIALS

6A \$4 25

INITIALS  
3A \$2 60

MEMORIAM  
123458  
H D

20 POINT WITH 28 POINT INITIALS

8A \$3 65

INITIALS  
4A \$2 10

PRICED RUBIES  
⊗ ≡ ⊗ ≡ ⊗  
NEAT DAME

TRINAL—Series Three

12

48 POINT

3A \$6 25

BREAK

36 POINT WITH 48 POINT INITIALS

4A \$5 40

INITIALS  
3A \$5 00

HINDERS

LBE

24 POINT WITH 36 POINT INITIALS

6A \$4 40

INITIALS  
3A \$3 50

RINK 5 FUN

N E H



PLUTO SERIES

15

48 POINT

4A \$5 50

SELFISH

36 POINT

5A \$4 25

FINE DRIVE

24 POINT

8A \$3 50

TALENTS GREAT  
UNFINISHED

18 POINT

10A \$3 00

SIXTEEN EXHIBITORS  
SHOWER FAVORS

12 POINT

16A \$2 25

BARE OF GRASS AND SUNSHINE  
END OF LONG SUMMER DAY

ELBERON No. 2

36 POINT

4A 6a \$8 80

Monuments  
HOUR

24 POINT

6A 10a \$6 70

Union Boys Solid  
HUMORISTIC

18 POINT

8A 14a \$5 25

Monolithes Serenaders  
Midnight 34  
WAKEGANTHE

12 POINT

10A 18a \$3 90

Enriched Ornithological Evidence  
Dramatic Hebrons  
MOONLIGHT SEANCE

**KOSTER SERIES**

---

24 POINT WITH 48 POINT INITIALS

3A 8A 12a \$9 65

Studios Players  
HONOR  
Great Farces

18 POINT WITH 36 POINT INITIALS

4A 10A 15a \$7 45

Mischievous Tendency  
LIVELY  
Garden Rambler

12 POINT WITH 24 POINT INITIALS

6A 14A 22a \$5 30

Dinner-Pails and Snow-Shovels  
RURAL SERVICE  
Household 345 Utensils

ART GOTHIC SERIES

15

72 POINT

3A 5a \$10 00

Finer Sash

60 POINT

4A 5a \$9 20

Compiled 84

48 POINT

4A 5a \$6 50

Great Victories

36 POINT

6A 8a \$5 00

Cultured People 86

24 POINT

8A 10a \$4 00

A Rose by any Other Name

18 POINT

12A 16a \$3 00

Red and White Morning Glories 548

12 POINT

14A 20a \$3 00

10 POINT

18A 28a \$2 75

Government Agencies | Sea Tale of Daniel Sailor

JOHNSON SERIES

60 POINT

3A 5a \$9 60

Reserving

48 POINT

3A 6a \$7 60

Large Corks

36 POINT

4A 8a \$6 20

Printing Houses

30 POINT

5A 10a \$5 75

Western Invention

24 POINT

6A 12a \$5 05

American Declaration

18 POINT

8A 16a \$4 35

Discovering Ancient Castles

1234567890

**DYNAMO SERIES**

---

48 POINT

3A 4a \$4 55

QUICK Service

36 POINT

4A 6a \$3 60

Promised TICKETS

24 POINT

8A 10a \$3 00

Government Bucketshops  
LOANING MONEY

18 POINT

10A 14a \$2 45

Cheap Trip Around the Continent  
FAMILY EXCURSION

12 POINT

16A 25a \$2 25

Industrial Proceeds Distributed Quarterly  
DELIGHTED COTEMPORARIES

1 2 3 4 5 6 7 8 9 0

**ARCHAIC SERIES**

---

36 POINT

7A 10a \$6 00

**GREAT Rumors**

30 POINT

8A 14a \$5 00

**Oriental IMPORTS**

24 POINT

10A 18a \$4 25

**EGYPTIAN Monument**

18 POINT

14A 26a \$3 75

**Participants COMPLIMENTED**

12 POINT

25A 40a \$3 10

**SCHOOLBOYS HUNTING the Bell-Wether**

9 POINT

30A 50a \$2 90

**Assortment of Magnificent Improvements Exhibited  
WAGGLING BUSTLE COMPANY**

6 POINT

36A 70a \$2 70

**Dispense Good Looks, Loving Words, Horsewhips and Deferred Hopes  
MESSIEURS ENROBE & GARNISH**

1 2 3 4 5 6 7 8 9 0

WALTON SERIES

36 POINT

4A 8a \$4 15

Northeastern Excursions  
NUMEROUS

30 POINT

5A 10a \$3 65

Handsomest 45 Merchandise  
DISCONTENTMENT

24 POINT

6A 12a \$3 15

Demolished Christmas Decorations  
AUGUST 68 NUMBER

18 POINT

8A 16a \$2 85

Madison Flower Boudoir Entertainment  
Terminated Saturday  
MAGNIFICENT PERFORMER



COLUMBIAN SERIES

60 POINT

3A 5a \$7 95

Refused Tickets

48 POINT

4A 6a \$6 70

Graceful Buildings

42 POINT

5A 10a \$6 00

Foreign 328 American

30 POINT

6A 16a \$5 10

Exposition Viewed Monthly  
American Resolution

24 POINT

8A 28a \$4 40

Celebrating Landing of Columbus 456  
Constitutional Amendments

NEWFANGLE SERIES

36 POINT

4A 12a \$5 60

PRINTING ◊ APPLIANCES  
SECOND  
LARGE ◊ DISPLAY

24 POINT

6A 18a \$4 85

MALE ◊ SUBMARINE ◊ DIVERS  
BY THE  
AQUATIC ◊ EXPLOITS

18 POINT

6A 24a \$3 95

SWINDLERS ◊ AND ◊ BLATHERSKITES  
FINCHEM ◊ COMPANY

1234567890

ECCENTRIC SERIES

15

36 POINT

6A \$3 50

GUEST • WELCOME

24 POINT

8A \$2 35

HARMONIOUS WORKERS

18 POINT

10A \$1 90

COMMITTEES • ON • ARBITRATION



5



7

1



8



6



2



3



4



2

EACH SIZE COMPLETE WITH ORNAMENTS

RIVET SERIES

12

24 POINT

8A \$2 00

FAVORED MAIDENS

18 POINT

10A \$1 50

DISGRACE YOUR POSITION

12 POINT

12A \$1 00

MARVELOUS INCIDENTS CONDITIONAL  
SHIELDS ORPHAN CHILDREN

FOSTER GOTHIC

12

48 POINT

4A \$4 75

ROSEBUDS

36 POINT

6A \$4 25

BANK 8 NOTE

30 POINT

7A \$3 75

ORANGE GROVES

24 POINT

8A \$3 50

FAMOUS BAND 65

18 POINT

10A \$2 75

SIXTH GRAND OPENING

12 POINT

14A \$2 25

RETURNED WITH HEARTY THANKS  
234 CIRCUS GIRLS COMBINE

**FOSTER GOTHIC EXTENDED**

— 12 —

48 POINT

3A \$5 75

DOWN

36 POINT

4A \$4 50

BROAD

24 POINT

6A \$3 75

HUSBANDS

18 POINT

8A \$3 00

MINTS 97 SNUG

12 POINT

10A \$2 50

SILVER CLUBS MODEL

10 POINT

15A \$2 25

ERECT STONE HORSE BARN

8 POINT

20A \$2 00

DEAD COUNTS GOLDEN BEAUTY 79

**FOSTER GOTHIC EXTENDED No. 2**

12

24 POINT

6A 8a \$6 00

Notice Beaver  
Surprise  
EXCITED

18 POINT

8A 10a \$5 00

Makes Rare Dates  
Procure 7  
DEMANDING

12 POINT

10A 12a \$4 00

Produce Comical Situations  
Sound Nickels  
ARTISTIC SINGERS

ELZEVIR GOTHIC

15

48 POINT

3A 6a \$8 00

MINE Shaft

36 POINT

5A 9a \$8 00

Roman CHIME

24 POINT

8A 16a \$5 00

Humorous Entertainer  
AMUSEMENTS

18 POINT

12A 24a \$4 50

Western Mountain Climbers  
QUARTZ HUNTING

14 POINT

15A 30a \$4 00

Romantic Adventurer Encouraged  
‡ CONGENIAL VOCATION ‡

12 POINT

18A 36a \$3 50

Perseverance Considered Indispensable  
STUDIOUS HABITS NECESSARY

10 POINT

20A 40a \$3 00

Prosperous Mechanic  
ESTABLISHMENT  
12345678

8 POINT

22A 44a \$2 75

Lucrative Situations Desired  
RELIABLE SERVANTS  
123456789

MULTIFORM No. 1

36 POINT

4A \$4 25

INNOCENT

30 POINT

5A \$3 75

WEST \* END

24 POINT

6A \$3 25

HEAD LARGER

18 POINT

8A \$2 75

GOBLETS 6 PLATED

MULTIFORM No. 2

36 POINT

4A \$4 25

INNOCENT

30 POINT

5A \$3 75

WEST \* END

24 POINT

6A \$3 25

HEAD LARGER

18 POINT

8A \$2 75

GOBLETS 6 PLATED

THE MULTIFORM SERIES MAKE A FINE EFFECT WHEN ONE IS PRINTED OVER THE OTHER  
IN DIFFERENT TINTS



MULTIFORM No. 3

15

36 POINT

4A \$4 25

INNOCENT

30 POINT

5A \$3 75

WEST  END

24 POINT

6A \$3 25

HEAD LARGER

18 POINT

8A \$2 75

GOBLETS 6 PLATED

MULTIFORM No. 4

15

36 POINT

4A \$4 25

INNOCENT

30 POINT

5A \$3 75

WEST  END

24 POINT

6A \$3 25

HEAD LARGER

18 POINT

8A \$2 75

GOBLETS 6 PLATED

THE MULTIFORM SERIES MAKE A FINE EFFECT WHEN ONE IS PRINTED OVER THE OTHER  
IN DIFFERENT TINTS

EREBUS SERIES

15

60 POINT

4A \$5 75

**FORECAST**

48 POINT

5A \$4 50

**NORTHEAST  
CAMP \$25**

36 POINT

6A \$3 50

**UNITED CHURCH  
CEMENTED**

24 POINT

8A \$2 25

**NOONTIME RECREATIONS  
WELCOME LUNCH 12**

THE EREBUS AND HADES SERIES MAKE A FINE EFFECT WHEN ONE IS PRINTED OVER THE OTHER  
IN DIFFERENT COLORS. ALL SIZES LINE TOGETHER AT THE BOTTOM

HADES SERIES

—15—

60 POINT

4A \$5 75

FORECAST

48 POINT

5A \$4 50

NORTHEAST  
CAMP \$25

36 POINT

6A \$3 50

UNITED CHURCH  
GEMENTED

24 POINT

8A \$2 25

NOONTIME RECREATIONS  
WELCOME LUNCH 12

THE HADES AND EREBUS SERIES MAKE A FINE EFFECT WHEN ONE IS PRINTED OVER THE OTHER  
IN DIFFERENT COLORS. ALL SIZES LINE TOGETHER AT THE BOTTOM

FILLET SERIES

36 POINT

4A \$4 85

SMILES

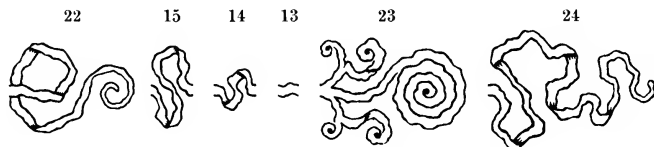

24 POINT

7A \$3 85

DEMIJOHNS

STONE

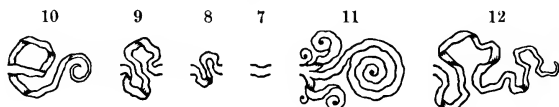

18 POINT

9A \$3 25

YOUNG GUARD

REGIMENT

12345

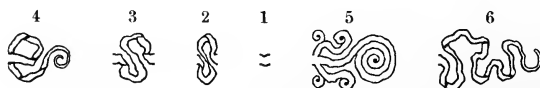

STIPPLE SERIES

48 POINT

6A \$6 90

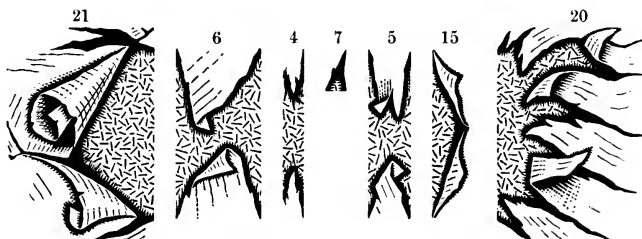

36 POINT

7A \$5 35



STIPPLE SERIES SHOWN IN COMBINATION



STEELPLATE GOTHIC

36 POINT

4A \$4 10

GOLD LINKS  
WORKING

24 POINT

7A \$3 00

GRAND ICEBERG  
OBSERVED

18 POINT

8A \$2 45

RELIABLE PRETENCE  
HOROSCOPERS

12 POINT

12A \$2 15

WEATHER MADE TO ORDER  
PROGNOSTICATOR  
1234567890

SHADOW SERIES

36 POINT

3A \$4 60

RED MEN

24 POINT

7A \$4 00

CHOIR MUSIC  
INTRIGATE

18 POINT

10A \$3 40

YOUTHS DANCING  
PLEASURE

12 POINT

16A \$2 75

PROMISING ASSOCIATION  
CONSOLIDATED

1 2 3 4 5 6 7

LURAY SERIES

36 POINT

3A \$5 40

PHONER

30 POINT

4A \$4 30

GROWING  
SHANK

24 POINT

5A \$3 35

HARD BARK  
STAUNCH

18 POINT

6A \$2 70

SOCIAL DANCE  
GERMANS  
1 2 3 4 5



ARBORET No. 2

4

24 POINT

6A \$5 50

HOT WAVE

18 POINT

8A \$4 90

MINCE TARTS

12 POINT

10A \$3 80

LATEST OPENING  
STYLISH CLOTHES



EACH SIZE COMPLETE WITH ORNAMENTS

ARGENT SERIES

12

36 POINT

4A 8a \$6 50

Variosus and Gustave

24 POINT

6A 12a \$4 50

Merchant National Insurance

CRAYON SERIES

36 POINT

3A 5a \$6 30

Grand Horses  
Untamed

24 POINT

5A 10a \$5 15

Atlantic & Delaware  
Floating Palace  
Steamboat

18 POINT

5A 12a \$4 05

Remembrances  
American & Australian  
Tourists Welcomed  
1 2 3 4 5 6 7

**RAPHAEL SERIES**

15

36 POINT

4A 6a \$5 50

PACING HORSE  
Assortment 58

24 POINT

6A 8a \$4 00

WARD CONVENTIONS  
Nine Candidates 9

18 POINT

10A 15a \$3 25

SEE THE MORNING SUNLIGHT  
Radiant and Golden Orb \$24

**VENUS SERIES**

15

30 POINT

7A \$3 25

HIGH WIND \$89

20 POINT

10A \$2 75

JOHNSTON RAILROAD

14 POINT

16A \$2 75

FINANCIAL TRANSACTION \$25

LITHOTINT SERIES

12

36 POINT

4A 8a \$6 75

Natures House  
DOMESTIC

24 POINT

6A 12a \$5 50

National Contractors  
Human 47  
SPECTATORS

18 POINT

8A 16a \$4 75

Michigan Short Companies  
Make Fast Time  
RECORDS MODERN

HALFTONE SERIES

12

36 POINT

4A 8a \$6 30

Modern Friends  
HOUSES

24 POINT

6A 12a \$4 50

Variety of Ornaments  
Extensive  
GESTICULATED

18 POINT

8A 16a \$3 95

Bombastes Furioso Pleasant  
Companion 58  
SUMMER OUTINGS

**SIGNET SHADE**

12

36 POINT

4A 8a \$7 30

Houses Remove  
Structures

24 POINT

6A 12a \$5 00

Musicians Contribution  
Enormous 456

**REMBRANDT**

12

36 POINT

5A \$2 85

BURNED HOUSES

24 POINT

7A \$2 15

ROMANTIC MOUNTAIN

18 POINT

10A \$2 00

SOUTHERN HORSES BOUGHT  
MODERN STORIES

**HERMES SERIES**

36 POINT

6A 10a \$5 50

HOSPITAL BUILDING  
Trained Nurses 5

24 POINT

10A 15a \$4 50

REMARKABLE PROCESSIONS  
Croakers Ancient Order

18 POINT

12A 18a \$3 25

CHIEF COMMISSIONER OF IMMIGRATION  
Gophers Restriction Enforced 5

12 POINT

18A 24a \$3 00

UNIQUE ROSEWOOD HOUSEHOLD FURNITURE FOR SALE  
Beautiful Design and Artistic Workmanship 23

UNIQUE CELTIC CONDENSED

36 POINT

4A 6a \$4 25

Clothing Sewers  
DEAREST

30 POINT

6A 8a \$3 75

Handsome Fashion  
Introduce  
REFORMERS

24 POINT

8A 10a \$3 25

Enchanting Seminarian  
DEMONSTRATIVE  
1234567



---

**UNIQUE CELTIC CONDENSED**

18 POINT

12A 16a \$3 00

Remarkable Daily Performance  
**WINSOME VIRGINS**

12 POINT

18A 30a \$2 75

Smockfrocked Blatherskites Gesticulating  
Charming Amusement  
**ORATORICAL PROMOTERS**

10 POINT

20A 34a \$2 50

Blithesome and High-Spirited Maids Captivated  
Recreative Entertainment  
**ANCIENT PARASOLS EXHIBITED**

8 POINT

25A 38a \$2 25

Enormous Stock Imported from Madeira at Liberal Prices  
Come Early and Investigate  
**PROVINCIAL GIMCRACK EXCHANGE**

6 POINT

30A 45a \$2 00

Neither Language nor Pencil can Magnify the Beauty of this Isle of Wonder  
Fortnightly Cruises During Summer Months  
**MAGNIFICENT EXPEDITIONS TO WONDERLAND**

1 2 3 4 5 6 7 8 9 0

UNIQUE CELTIC

36 POINT

4A 6a \$6 20

Rude SIGN

30 POINT

6A 8a \$5 35

HARD Chairs

24 POINT

7A 10a \$4 05

Quaint REMARK

18 POINT

10A 14a \$3 60

DELIGHTED Traveler

14 POINT

12A 18a \$3 25

Spring FREIGHT Charge

12 POINT

15A 22a \$3 00

PARISIAN Trimming Display

10 POINT

18A 28a \$2 90

Unbiased Decision INTERPRETED

8 POINT

20A 32a \$2 60

SPACIOUS POTHOUSE Patrons Delighted

6 POINT

22A 35a \$2 50

Enchanting AURIFEROUS DUMPING Grounds

WEBSTER SERIES

36 POINT

3A 6a \$5 00

Bright 5 Metal  
RIGHT SABRE

24 POINT

6A 10a \$4 00

General Applause 56  
NOTABLE ARTICLE

18 POINT

8A 14a \$3 25

Picking Blooming Flowers \$15  
BOSTON PUBLIC GARDEN

12 POINT

12A 22a \$3 00

Particular African 47 Forest Beautifying  
Pongowanka Defeats Kämpolon's Forces  
ELEVATED MASTODON ELEPHANTS

10 POINT

16A 22a \$2 75

Weary Tramp Ended 345 Greater Jaunt Home  
Marauders Repented Pardoned Then Executed  
COMMONWEAL ARMY NOW DECAPITATED

MURAL SERIES

48 POINT

4A \$5 25

GRANDER

42 POINT

5A \$4 75

DISTRUSTS

36 POINT

6A \$4 25

GREAT MIND

30 POINT

6A \$3 50

RIVER THAMES  
OXFORD 24

24 POINT

8A \$3 25

SIMPLE FRIENDS  
ENDEARED 98

MURAL SERIES

20 POINT

9A \$2 50

COVENTRY ROTATION  
◁ WHEELING 53 ▷

18 POINT

10A \$2 50

RAMBLING TRAVELLER  
ENJOYMENT 25

12 POINT

18A \$2 25

SEVERAL QUALIFIED STUDENTS 12  
◁ ARBITRATE DUTCH DISPUTE ▷

10 POINT

20A \$2 00

CONSTANTINE EXHIBITING INVENTIONS  
MERITING GREAT REWARDS

8 POINT

26A \$1 75

ROMANTIC PRODUCTS OF FANTASTIC LITERATURE  
◁ TRADING SCHOONERS COASTING \$365 ▷

6 POINT

26A \$1 50

TYPOGRAPHERS ANNUAL VACATION TO THE WHITE MOUNTAINS  
349 DELEGATES TRAVELLING THITHERWARD

FACADE SERIES

---

60 POINT

5A \$6 50

DABSTER 2

54 POINT

5A \$5 50

9 QUOTINGS

48 POINT

5A \$4 75

HARDENING 4

42 POINT

6A \$4 25

5 ADVENTURER

36 POINT

8A \$4 00

FRESH \$6 LOAVES

FACADE SERIES

30 POINT

9A \$3 50

DISENCHANTMENT 97

24 POINT

12A \$3 25

HOMELESS 81 WAYFARER

20 POINT

16A \$3 00

PRODUCERS 5 CONSOLIDATED

18 POINT

18A \$2 75

◇ ENGRAVING \$439 MACHINERY ◇

12 POINT

25A \$2 25

DESTROYED CHILDHOOD'S PLEASANT MEMORIES 96

10 POINT

30A \$2 00

◇ MULTIPLYING GEAR GAINS CONSIDERABLE MOMENTUM ◇

8 POINT

36A \$1 75

EGYPTIAN ORNAMENTS SHIPPED WEDNESDAY LARGEST INVOICE RECEIVED  
FOUR EVENINGS DURING THE MONTH OF DECEMBER

6 POINT

36A \$1 50

WONDERFUL PERFORMANCES OF TRAINED ANIMALS BROUGHT THEIR TRAINERS WEALTH  
◇ PERSEVERANCE COUPLED WITH UNLIMITED 756 PATIENCE REQUIRED ◇

FACADE CONDENSED

72 POINT

9A \$7 25

BEAUTEOUS DELIGHT

60 POINT

12A \$6 75

SIMPLEST DECORATION

54 POINT

12A \$6 00

FORTY DRAMATIC CLUBS

48 POINT

12A \$5 25

RENTING ELEGANT HOUSE

42 POINT

14A \$4 50

USEFUL FOR LIMITED SPACE



FACADE CONDENSED

2

36 POINT

16A \$4 00

SPLENDID TYPE FOR SQUEEZING

30 POINT

16A \$3 50

OLD NEPTUNE OFTEN SEEMS ENRAGED

24 POINT

20A \$3 00

UNAVOIDABLE BUT LAUGHABLE SITUATION

18 POINT

28A \$2 75

GENERAL GORDON'S VALIANT DEFENCE OF KHARTOUM  
THE MAHDIS OVERWHELMING HORDES \$345

16 POINT

30A \$2 50

DESTROY THAT NOBLE KNIGHT SUCCOR COMES TOO LATE  
BRAVE SOLDIERS TOIL ALONG THE NILE \$5678

12 POINT

40A \$2 25

THROUGH COUNTLESS DESERT DANGERS TO HIS RESCUE AND RETURN  
WITH MOURNFUL TIDINGS 1894 REST SPOTLESS KNIGHT

10 POINT

46A \$2 00

ENGLAND REVERENCES THY MEMORY STILL BRAVE CHEVALIER WITHOUT REPROACH  
THY CHRISTIAN LIFE SHALL BE AN INSPIRATION TO HER SONS \$365

FACADE CONDENSED No. 2

72 POINT

9A 12a \$13 50

Choicest Preserves

60 POINT

12A 16a \$12 50

Bringing Cash Receipts

54 POINT

12A 16a \$10 75

Impetuous Philanthropy

48 POINT

12A 16a \$9 00

Excellent Toning Solutions

42 POINT

14A 18a \$8 25

Punctuating Faulty Manuscript

FACADE CONDENSED No. 2

36 POINT

16A 20a \$7 00

Exquisite Passenger Appreciated 6

30 POINT

16A 20a \$6 00

5 Delighted Mariner Arousing Neptune

24 POINT

20A 24a \$5 00

Great Struggle Between England and Soudan 9

18 POINT

28A 32a \$4 75

Charitable Societies Distributing Summer Clothing 342

16 POINT

30A 34a \$4 00

Robin Hood and his Merry Outlaws Chasing the Kings Red Deer  
Friar Tuck Jolly Unfrocked Priest Absolves Them 34

12 POINT

40A 44a \$3 75

Sherwood Forest Their Retreat Stalwart Forms Glad in Lincoln Green  
They Robbed the Rich and Bountifully Relieved the Poor \$5876

10 POINT

46A 50a \$3 25

Remarkable Longbow Shooting Measured Mile Robins Fairest Sweetheart Maid Marion  
Renowned Throughout Centuries in History, Tradition and Song 23567

VICTORIA ITALIC

—15—

24 POINT No. 1

8A \$3 75

TRIUMPHS  
EUROPE

24 POINT No. 2

8A \$3 25

EDINBURGH  
HERALD

18 POINT No. 1

12A \$3 25

FRENCH MAID  
CHARMING

18 POINT No. 2

12A \$2 75

BLUE MOUNTAIN  
HIGH POINT

12 POINT No. 1

16A \$2 50

MODERN ORNAMENTS  
FOREIGN DESIGN

ALL SIZES LINING TOGETHER AT THE BOTTOM.

VICTORIA ITALIC

15

12 POINT No. 2

16A \$2 25

*DIRECTORY FOR BRIGHTON  
BUSINESS EXCHANGE*

12 POINT No. 3

18A \$2 00

*EXCELLENT PRINTING MATERIAL  
HANDSOME ENGRAVER*

6 POINT No. 1

30A \$2 50

*WHERE BABY OAKS PLAY IN THE BREEZE  
GREEN GARMENTS OF THE TREES*

6 POINT No. 2

30A \$2 25

*BEYOND THE LILAC AND THE MAY SHE WAITS HER  
LOVE FROM ALIEN LANDS IMPATIENTLY*

6 POINT No. 3

30A \$2 00

*ON CALAIS SANDS MUST MAN WITH MAN WASH HONOR  
CLEAN IN BLOOD TO-DAY; ON SPACES WET FROM*

6 POINT No. 4

36A \$2 00

*WATER WAN HOW WHITE THE FLASHING RAPIERS PLAY, PARRY  
RIPOSTE, AND LUNGE! THE FRAY SHIFTS FOR A*

6 POINT No. 5

36A \$2 00

*WHILE, THEN MOURNFUL STANDS THE VICTOR; LIFE EBBS FAST AWAY  
A LITTLE SPACE OF SILENCE THEN THE MORNING GRAY*

ALL SIZES LINING TOGETHER AT THE BOTTOM

JAGGED SERIES

12 POINT No. 39

12A \$1 75

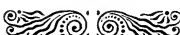
SOME BOOKS CAN BE TASTED  
 OTHERS SWALLOWED  
④ ④ ④ ④ VERY FEW DIGESTED  
 1234567890 & \$ AND 0

12 POINT No. 40



14A \$1 75

THE LEARNED SOCIETIES AND PRINTING CLUBS OF THE UNITED  
KINGDOM. © © HUME, 1847  
1234567890 & \$ AND 0



12 POINT No. 41

18A \$1 75

RUSSIAN PLAYING CARDS, MARVELLOUSLY  
 BEAUTIFUL, WERE ADMIRIED AT  
④ ④ ④ ④ THE PARIS EXPOSITION, 1867  
 1234567890 & \$ AND 0

EUROPEAN ACCIDENT INSURANCE Co  
23 AND 45 SUMMER STREET, BOSTON

OUTING SERIES

12 POINT No. 46

14A \$2 00

ESTABLISHED SINCE 1568  
IDEAL COMEDY CO

12 POINT No. 47

18A \$1 75

FASHIONABLE TO STRANGERS  
HEROIC LIFE SAVING CO 30

12 POINT No. 48

18A \$1 75

UNFIT LETTER FOR POSTER PRINTER  
DELICATE AND BEAUTIFUL 92

6 POINT No. 43

30A \$1 75

EXQUISITE TOURISTS' GUIDES TO PLEASURE  
THE MANHATTAN PRINTING CO  
43 AND 56 SOUTH WASHINGTON STREET

6 POINT No. 42

20A \$1 75

ANNUAL SACRIFICE OF PROSPEROUS YOUNG GENTLEMEN  
SNARE-SETTING OF ANXIOUS PARENTS 28  
FASHIONABLE MATRIMONIAL SEASON OPENING

6 POINT No. 45

40A \$1 50

YOUNG LADIES JEMINARY  
EDUCATED AND REFINED MAIDEN  
GRADUATE 254 HONORS

6 POINT No. 44

40A \$1 50

MITHRAS GRAND DEITY OF THE  
ANCIENT PERSIANS, SUPPOSED TO BE  
THE JUN OR FIRE GOD 347

MMMMMM

MMMMMM

**ELANDKAY SERIES**

18 POINT No. 29

12A \$2 00

ENORMOUS HEIGHT 89

18 POINT No. 28

14A \$1 75

67 REFRESHING CLIMATES

12 POINT No. 27

16A \$1 50

THE TWELVE POINT SIZES £542

12 POINT No. 26

18A \$1 50

32 POPULAR CONDENSED SPECIMENS  
WELCOMED EVERYWHERE

12 POINT No. 25

24A \$1 50

EXCITING FOOTBALL GAMES FOR SPRINGFIELD  
HARVARD AND YALE COLLEGES 1894

6 POINT No. 24

30A \$1 50

CONVENIENT AND ARTISTIC SERIES FOR JOB PRINTERS  
MADE FROM COPPER ALLOY METAL

6 POINT No. 23

30A \$1 50

COMMERCIAL WORK, PROGRAMS, DANCE ORDERS, INVITATIONS  
HANDY FOR EVERY DAY USE IN ANY OFFICE 452

6 POINT No. 22      40A \$1 25  
IMPORTED GOODS IN MILLINERY  
12 AND 34 TREMONT ROW

6 POINT No. 21      40A \$1 25  
PERFECT ALIGNMENT OF THIS SERIES  
THE BOTTOM GUARANTEED



**GOTH SERIES**

24 POINT

12A \$3 35

SPICY 49 JOKES

18 POINT

18A \$3 15

57 WINE MERCHANT

12 POINT

30A \$2 65

EXTRA FREIGHT RATES 32

10 POINT

30A \$2 25

69 UNBIASED DECISIONS GIVEN

8 POINT

40A \$2 25

CLEARCUT TYPE FOR ADVERTISERS 56

6 POINT

50A \$2 00

27 MAGNIFICENT DEDICATORY MILITARY PARADE

**NORMAN CONDENSED**

36 POINT

5A 6A \$4 50

MUSCLE CONTEST

24 POINT

5A 8A \$3 83

FOUNDRY 45 WORKS

18 POINT

10A 16A \$3 15

HEALTHY EXERCISES EMBODIES

12 POINT

20A 32A \$2 95

10 POINT

20A 32A \$2 93

STRONG ANIMALS SINGULAR EXAMPLES

**MORNING GLORY**

36 POINT

7A 12a \$5 00

Pleasing, Soul-Inspiring Music  
Invite Handsome Gentlemen

24 POINT

12A 20a \$4 00

Dramatic and Literary Programmes \$258  
Historical Romances Proclaimed

18 POINT

12A 32a \$3 25

Handsome Women and Girls Always Admired by Men  
Forever Looking for Amiable and Charming Ladies 19

---

**GRIMALDI SERIES**

24 POINT

7A 14a \$4 50

GROTESQUE · CREATURE  
© Design Useful Faces ©

18 POINT

8A 16a \$3 50

CURIOUS CONCERTS PRODUCED  
✱ Morning and Evening 15th ✱

ORNAMENTS WITH EACH SIZE

**GUTENBERG SERIES**

24 POINT

5A 10a \$3 60

Neptune • Banking • Company

18 POINT

6A 14a \$3 20

Inspecting and Drilling New Squads

12 POINT

8A 20a \$2 45

Cosmopolitan Finance Company Provides Methods  
1 2 3 4 5 6 7 8 9 0

**SIGNET SERIES**

36 POINT

4A 8a \$6 60

Removes Watches

24 POINT

6A 12a \$4 40

Unanimous 56 Democratic

18 POINT

8A 16a \$3 85

Northern Government Combination

12 POINT

10A 20a \$2 70

Manufacturers Reorganizations Overestimated

9 POINT

12A 24a \$2 10

Remarkable Theatrical Phenomenon Rehearsing Christopher  
Magnificent Household Furniture Decorations

**RAMONA SERIES**

15

30 POINT

6A 14a \$4 75

8 Entrancing Jolliest Charmers 4

24 POINT

8A 20a \$4 60

276 Californian Wine Productions 148  
Sparkling Thoughts of Boyhood

18 POINT

10A 32a \$4 50

564 Rendering Selections Enchantingly 243  
\$ £ Th Ph Qu ly ng £

---

**PENCILINGS**

12

20 POINT No. 2

8A 24a \$4 70 24a \$2 45

Harrowing. Accounts. Proved. Authentic

20 POINT

8A 24a \$5 55 24a \$3 30

Superior. Conductor. Abandoned

10 POINT

8A 30a \$2 90 30a \$1 90

Brave. Knights. Sporting. Golden. Shield. Enamoured  
Unfortunate 426 Encounters

**PALO ALTO**

15

24 POINT

6A 20a \$5 50

52 Moonlight on the Waters 24  
UNCOMPLAINING

18 POINT

8A 26a \$5 00

4 Down wild New Hampshire Valley 8  
BI-ANNUAL BANQUET

**SANTA CRUZ**

15

24 POINT

18A \$3 75

538 DRAMATIC ♦ MUMMERIES  
EVENING FROLIGS

18 POINT

24A \$3 00

6 ARTISTIC ♦ PAINTINGS ♦ STATUARY 5  
PEACHBLOWN CURIOS

12 POINT

30A \$2 50

68 REFRESHING ♦ MIGNONETTE ♦ PERFUMERY 24  
OR SHIMMERING FIELDS

**EUCLID SERIES**

12

48 POINT WITH 72 POINT INITIALS

3A 3A 5a \$16 80

Decorum  
HOES

36 POINT WITH 60 POINT INITIALS

3A 4A 6a \$13 30

North Resort  
REACH

30 POINT WITH 48 POINT INITIALS

3A 5A 8a \$11 30

Deacon Enters  
56 SONG

**EUCLID SERIES**

24 POINT WITH 36 POINT INITIALS

3A 6A 10a \$7 60

Northern Gardeners  
HUMORS

18 POINT WITH 30 POINT INITIALS

3A 8A 14a \$6 75

Exhibitions Remarkable  
MECHANICAL

12 POINT WITH 24 POINT INITIALS

4A 10A 18a \$4 75

Unanimous Eastern Convention  
Produce Merchant  
RENOWNED BUILDERS

10 POINT WITH 18 POINT INITIALS

4A 10A 18a \$3 85

Richest Diamond Regions Known  
Hand 5678 Made  
HANDSOME DECORATION

**CHINESE SERIES**

24 POINT

6A \$2 40

DEMAS SHIELD

18 POINT

8A \$2 25

RICHEST MORSELS

12 POINT

10A \$1 60

CHRISTMAS ZUM BISMARCK

9 POINT

12A \$1 20

SWEETLY SOUNDING THROUGH SKIES

---

**ALPINE SERIES**

36 POINT

4A 8a \$5 80

Historic Movement

24 POINT

6A 12a \$4 35

Highland Costumes Ethereal

18 POINT

8A 16a \$3 65

Honesty Eliminated Through Perversity

12 POINT

10A 20a \$2 35

Emotional Sensations Governing Universal Education



OXFORD No. 2

—12—

36 POINT

6A \$3 75

3A (Initials) 6A \$6 95

**D**OGS **R**UIN  
HOME

24 POINT

8A \$2 95

3A (Initials) 8A \$4 55

**H**ORSE **S**HOERS  
ENDURE 86

18 POINT

10A \$2 60

4A (Initials) 10A \$4 20

**R**EPORTED **M**USICAL  
BOSTONIAN

12 POINT

12A \$1 35

5A (Initials) 12A \$2 40

**N**ORTHERN **L**IHTS **B**ETRAYED  
ANXIOUS 68 MARINER

LONGFELLOW SERIES

72 POINT

3A 6a \$12 00

White Roses

60 POINT

4A 9a \$11 00

Modern Chair

54 POINT

4A 9a \$10 00

Correct Shades

48 POINT

4A 10a \$9 00

Humane Person

42 POINT

4A 10a \$8 00

National Question

LONGFELLOW SERIES

36 POINT

4A 12a \$7 00

American Industries

30 POINT

5A 14a \$6 00

Famous Seaside Resorts

24 POINT

7A 16a \$5 00

Reputation Sustained  
European Information Bureau

18 POINT

9A 22a \$4 50

Beautiful Mountain Verdure  
Cedarville Electric Traction Railroad

12 POINT

14A 40a \$4 00

Second Charitable Musical Cantata  
Millionaires Patronize Instrumental Entertainment

10 POINT

14A 40a \$3 50

Memorable Document  
Valuable Historic Reminder  
1 2 3 4 5 6 7 8 9 0

8 POINT

14A 40a \$3 00

Attractive Proscenium  
Handsome Interior Decoration  
1 2 3 4 5 6 7 8 9 0

**POSTER COMMERCIAL**

8 POINT

Card Font 20A 30a \$1 75  
Circular Font 60A 25A 350a \$11 50

THE INVENTION OF PRINTING has always been recognized by men of education as a subject of great importance: there is no mechanical art, nor are there any of the finer arts, about whose history so many books have been written. The subject is as mysterious as it is inviting. There is an unusual degree of obscurity about the origin of the first printed books and the lives and works of the early printers. There are records and traditions which cannot be reconciled of at least three distinct inventions of book printing. Its earlier history is

10 POINT

Card Font 16A 24a \$1 80  
Circular Font 60A 25A 250a \$12 25

THE INVENTION OF PRINTING has always been recognized by men of education as a subject of great importance: there is no mechanical art, nor are there any of the fine arts, about whose history so many books have been written. The subject is as mysterious as it is inviting. There is an unusual degree of obscurity about the origin of the first printed books and the lives 56

12 POINT

Card Font 12A 20a \$1 80  
Circular Font 48A 20A 200a \$11 25

THE INVENTION OF PRINTING has always been recognized by men of education as a subject of great importance: there is no mechanical art, nor are there any of the fine arts, about whose early history so many books have been written. The subject is as mysterious as it is now 365

POSTER COMMERCIAL

12

18 POINT

Card Font 10A 16a \$2 50

Circular Font 20A 10A 125a \$11 75

THE INVENTION OF PRINTING has always been recognized by men of education as a subject of great importance: there is no mechanical art, nor are there any of the fine arts, about whose early history so many fine books have been written. The subject is 58

28 POINT

Card Font 6A 12a \$3 65

Circular Font 10A 5A 42a \$9 75

INVENTION OF PRINTING has been recognized by men of education as a subject of importance: there is no mechanical art, nor are there at 94

IVANHOE SERIES

36 POINT

4A 5a \$5 50

Horse Races  
MENDS

30 POINT

4A 6a \$5 25

Roman Banker  
MONSTER

24 POINT

6A 10a \$4 75

Numbers Removed  
HARMONIUMS

18 POINT

8A 12a \$3 75

Remarkable Examinations  
Remove 568  
CHINESE GARDENS

**IVANHOE SERIES**

12

12 POINT

Card Font 10A 16a \$2 40  
Circular Font 25A 125a \$11 75

**ORIGINAL DESIGNERS**

We supply everything required in the Printing line, and make sales satisfactory in every particular. Get our prices and liberal terms before placing your orders

**\$1234567890**

10 POINT

Card Font 10A 18a \$2 35  
Circular Font 30A 140a \$11 85

**LATEST PRACTICAL POINTERS**

Advertising seems to be an art yet to be discovered by numerous people. A constant stream of water from one or more engines will soon extinguish a fire, while a small pail of water thrown around has little or no effect

**\$1234567890**

8 POINT

Card Font 12A 20a \$2 40  
Circular Font 36A 150a \$10 75

**MODERN TECHNICAL DEVICES**

The abundant supply of excellent and magnificent typographic designs of every description just now presented to the choice of the Printer, and the highly cultivated tastes and exacting ideas of his patrons render it not only comparatively easy but necessary for him to attain to excellence in his workmanship

**\$1234567890**

**SKJALD SERIES**

60 POINT

4A 5a \$10 35

Pained 6

48 POINT

4A 5a \$8 65

Hard Fate  
Steamer 4

36 POINT

6A 8a \$7 50

Quaint Faces  
Great 2 Horn



SKJALD SERIES

24 POINT

8A 10a \$5 50

Ancient 14 Acting  
Massachusetts

18 POINT

10A 14a \$5 00

Players & Brotherhood  
Champion League

12 POINT

14A 24a \$4 00

Innocent Rastic Residents Farewell  
Charming Woodlawn Melody 14

10 POINT

16A 32a \$3 50

Numerous Assortment of Designs for Competition  
Used Exclusively Throughout Boston 56

8 POINT

18A 32a \$3 00

For Foreigners Supported by the United States Government  
European Countries Heavily Represented  
Charitable Institutions for the Poverty Stricken

m m m m m m m m

FLORENTINE OLD STYLE No. 2

---

72 POINT

4A 5a \$9 50

Ocean 8

60 POINT

4A 5a \$9 00

5 Mexican  
CHARMER

48 POINT

5A 5a \$7 00

Great 6 Port  
CRUSADERS

FLORENTINE OLD STYLE No. 2

36 POINT

6A 8a \$6 00

Boston 5 Herald  
Buildings  
FAKE BUOY

24 POINT

10A 10a \$5 00

Grand National Event  
Norman Street  
BANQUET HONOR

18 POINT

15A 14a \$4 50

Bacchantes Winter Home ♂  
Favoring Children  
AMERICAN ABORIGINES

**FLORENTINE OLD STYLE No. 2**

12 POINT

20A 24a \$3 75

LARGE SENTIMENT IN FAVOR

General Foster found the Hawaiian government indisposed to grant any further concessions west until the congress of the United States had decided to \$12345780

10 POINT

25A 32a \$3 25

PROPOSED INDIVIDUAL SERVICE OPPOSED

This committee felt itself unable to cope adequately with the medical, scientific, religious and various phases of the subject, and appointed a sub-committee whom they con £1234567890

8 POINT

30A 32a \$2 75

THE FLORENTINE OLD-STYLE SERIES, TEN SIZES  
CLASSIC ITALIAN LETTER

Florentine Old-Style is the nearest approach to the modern decorative artist's pen lettering that has yet been attained. Others have copied the individual characters, but it has remained for Florentine Old-Style to occupy a given \$68947

6 POINT

36A 40a \$2 50

MEMORY IT IS SAID IS INDISPENSABLE TO MORAL ECONOMY  
WITHOUT MYSTERIOUS PRIVATE SECRETARY

The faculty of memory, which receives and retains ideas and images and which exhibits them again with or without the exercise of volition, early became the subject of philosophical research. There are very many curious phenomena connected with this power of the mind; it is sometimes as recreant to its trust when most its service may be wanted, as the veriest bankrupt 567843

 SKETCH OF THE TYPES AND TYPEFOUND-  
ING OF THE FIRST PRINTERS.

**F**OR four centuries the noise of controversy has raged round the cradle of Typography. Volumes have been written, lives have been spent, fortunes have been wasted, communities have been stirred, societies have been organized, a literature has been developed, to find an answer to the famous triple question: "when, where, and by whom was found out the unspeakably useful art of printing books?" And yet the world to-day is little nearer a finite answer to the question than it was when Ulric Zel indited his memorable narrative to the Cologne Chronicle in the year 1499. Indeed, the dust of battle has added to, rather than diminished, the mysterious clouds which envelop the problem, and we are tempted to seek refuge in an agnosticism which almost refuses to believe that printing ever had an inventor. It would be neither suitable nor profitable to encumber an investigation of that part of the History of Typography which relates to the types and typemaking of the fifteenth century by any attempt to discuss the vexed question of the invention of the Art. The man who invented Typography was doubtless the man who invented movable types. Where the one is discovered, we have also found the other. But, meanwhile, it is possible to avail ourselves of whatever evidence exists as to the nature of the types he and his successors used, and as to the methods by which those types were produced, and possibly to arrive at some conclusions respecting the earliest practices of the Art of Typefounding in the land and in the age in which it first saw the light. No one has done more to clear the way for a free investigation of all questions relating to the origin of printing than Dr. Van der Linde

## DR. VAN DER LINDE ON THE ORIGIN AND DEVELOPMENT OF PRINTING. ❁❁❁❁❁



CANNOT say often enough that, when we speak of Typography and its invention, nothing is meant, or rather nothing must be meant, but printing with loose (separate, movable) types (be they letters, musical notes, or figures), which therefore, in distinction from letters cut on wooden or metal plates, may be put together or separated according to inclination. One thing therefore is certain: he who did not invent printing with movable types, did, as far as Typography goes, invent nothing. What material was used first in this invention; of what metal the first letters, the patrices (engraved punches) and matrices were made; by whom and when the leaden matrices and brass patrices were replaced by brass matrices and steel patrices; all this belongs to the secondary question of the technical execution of the principal idea: multiplication of books by means of multiplication of letters, multiplication of letters by means of their durability, and repeated use of the same letters, i. e., by means of the independence (looseness) of each individual letter (movableness). If this principle be adopted — and we can hardly imagine it questioned — it will be obvious that a large class of works which usually occupy a most prominent place in inquiries into the origin of Printing, have but slight bearing on the history of Typography. The block books of the fifteenth century had little direct connection with the art.

No. 4259 \$1.25

10 POINT JENSON OLD STYLE 25A 30a \$3 00

## MOVABLE TYPES



**I**T is reasonable to suppose that the first idea of movable type may have been a suggestion to the mind of the inventor by a study of the works of an old xylographic printer, and an observation of the cumbersome and wearisome method which was adopted in producing his books. The toil involved in first painfully tracing the characters and figures, reversed, on the wood, then of engraving them, and finally of printing them with the froton, would appear—in the case, at any rate, of the small school-books, for the production of which this process was largely resorted to—scarcely less tedious than copying the required number by the deft pen of a scribe. And even if at a later period, the bookmaker so far facilitated their labors as to write their text in the ordinary manner on prepared paper, or with prepared ink, and so transfer their copy on to the wood, the labor expended in proportion to the result, and the uselessness of the blocks when once their work was done, would doubtless impress an inventive genius with a sense of dissatisfaction and impatience

## FIRST STAGE BETWEEN XYLOGRAPHY AND TYPOGRAPHY.



WE can imagine him examining the first page of an Abecedarium, upon which would be engraved in three lines, with a clear space between each character, the letters of the alphabet, and speculating, as Cicero had speculated centuries before, on the possibilities presented by the combination in indefinite variety of those twenty-five symbols. Being a practical man as well as a theorist, we may suppose he would attempt to experiment on the little wood block in his hand, and by sawing off first the lines, and then some of the letters in the lines, attempt to arrange his little types into a few short words. A momentous experiment, and fraught with the greatest revolution the world has ever known! No question has aroused more interest, or excited keener discussion in the history of printing, than that of the use of movable wooden types as a first stage in the passage from Xylography to Typography. ❁❁❁❁❁❁❁❁❁❁

14 POINT JENSON OLD STYLE 15A 25a \$3 50



18 POINT JENSON OLD STYLE

12A 20a \$4 00



**HOSE WHO WRITE** on the affirmative side of the question profess to see in the earlier typographical works, as well as in historical statements handed down by the old authorities, the clearest evidence that wooden types were used, and that several of the most famous works of the first printers were executed by their means. As regards the latter source of their confidence, it is at least remarkable that no single writer of the fifteenth century makes the slightest allusion to the use of wooden types. Indeed, it was not till Bibliander, in the year 1548, first mentioned and described these letters.

10A 15a \$4 50

24 POINT JENSON OLD STYLE

**F**IRST THEY CUT their letters, he says, on wood blocks the size of an entire page, but because the labor and cost of that way was so great, they devised movable wooden types, perforated and joined one to the other by a thread. The legend, once started, found no lack of sponsors, and the typographical histories of the sixteenth century coincide more

30 POINT JENSON OLD STYLE

6A.10a \$5.00



**F** THE various testimonies, those only are deserving of attention which are professed to be based on actual inspection of the alleged perforated wood type. Specklin (who died in 1588) asserts that he saw some of these relics at Strasburg.

36 POINT JENSON OLD STYLE

5A 8a \$5 50

ANGELO in 1591, vouches  
ROCCHIA, for the existence  
 of similar letters

42 POINT JENSON OLD STYLE

4A 6a \$7 25

BODMIAN, SAW THE  
same worm-eaten type 17

48 POINT JENSON OLD STYLE

THE TESTIMONY  
proves nothing further

4A 5a \$7 75

54 POINT JENSON OLD STYLE

VENICE, MENTZ  
8 perforated types 

4A 5a \$10 25

60 POINT JENSON OLD STYLE

4A 5a \$12 25

WHICH MANY

writers 13 uphold

72 POINT JENSON OLD STYLE

4A 5a \$17 00

FIRST Printer



Series 80

### Jenson Initials

Series 80.....50c each  
Series 79.....60c each

ANY LETTER SUPPLIED



Series 80



Series 79—Style 13



Series 79



Series 79—Style 2



Series 77

### Morris Initials

Series 76.....75c each  
Series 77.....60c each  
Series 78.....50c each

ANY LETTER SUPPLIED



Series 77



Series 76

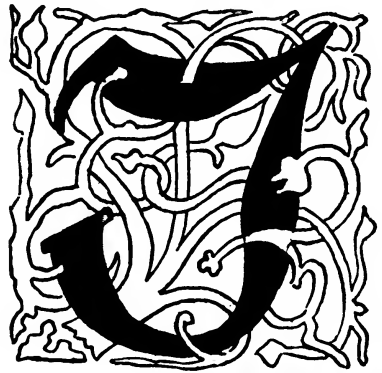

Series 76



Series 78



Series 78



Series 78

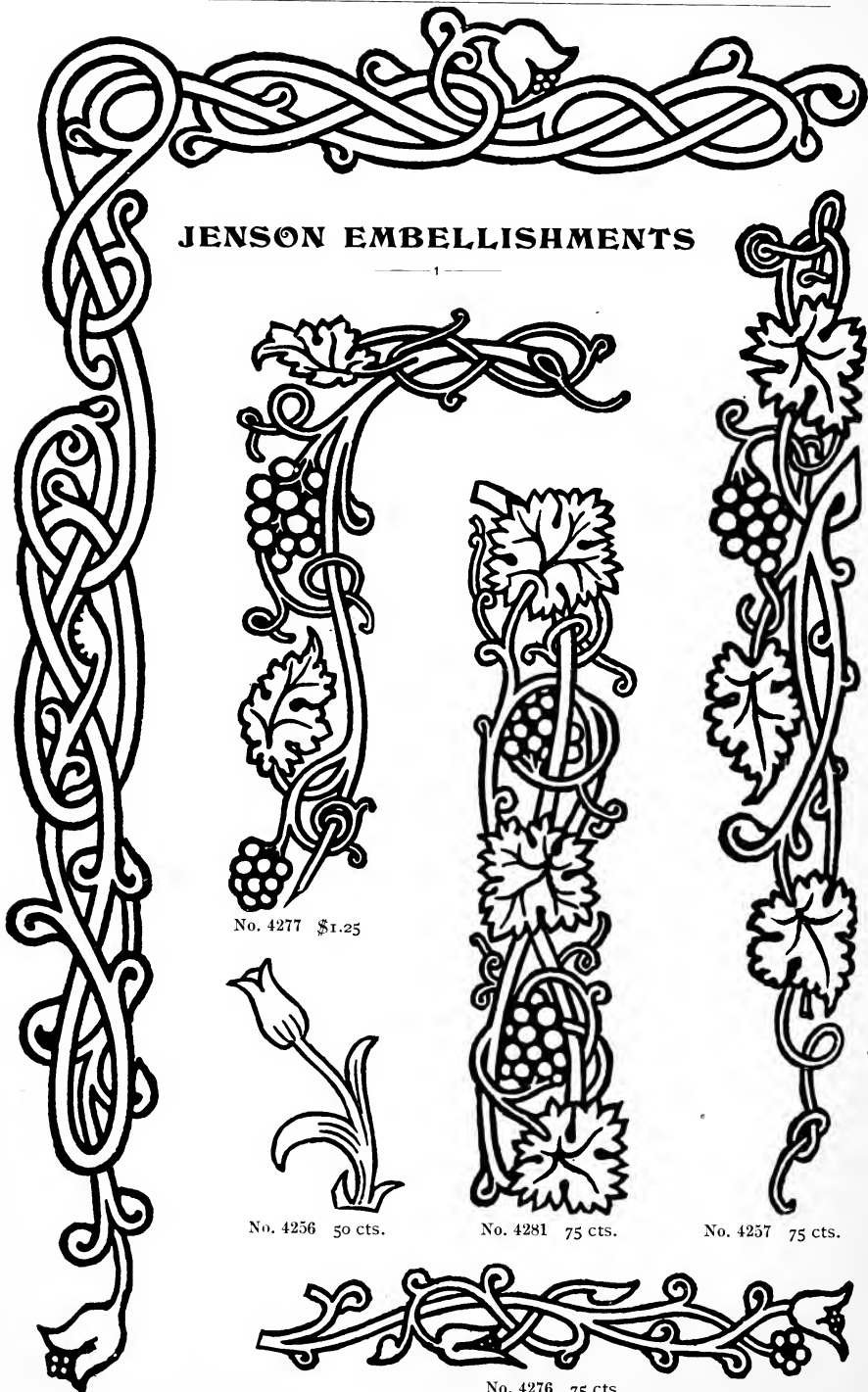

JENSON EMBELLISHMENTS

No. 4277 \$1.25

No. 4256 50 cts.

No. 4281 75 cts.

No. 4257 75 cts.

No. 4276 75 cts.

No. 4269 \$1.75



JENSON ITALIC

54 POINT

4A 5a \$10 25

*MEN* *Hired*

48 POINT

4A 5a \$7 75

*Great Scouts*  
*INDIAN*

42 POINT

4A 6a \$7 25

*Quaint Edition*  
*REVISED*

36 POINT

4A 8a \$5 50

*Caxtonian Border*  
*INVENTOR*

OTHER SIZES IN PREPARATION

JENSON ITALIC

---

30 POINT

5A 10a \$5 00

*The Italian scribes of  
the 15th century were  
famous for the grand  
display in manuscripts*

**JENSON DESIGN**

24 POINT

6A 15a \$4 50

*The Cicero de Oratore is  
claimed by some as one of  
the first books printed in a  
Roman type, although the  
traditions of 1460 are seen*

**POINTED GOTHICS**

OTHER SIZES IN PREPARATION

## JENSON ITALIC

18 POINT

10A 25a \$4 00

*This Jenson Italic proof exhibits a variation of types founded by the American Type Founders Co. 96*  
**UNITED STATES AMERICA**

12 POINT

18A 40a \$3 25

*The printing invention has always been recognized by educated men as a subject of great importance: there is no mechanical art, nor are there any of the fine arts, about whose* £50  
**RECOGNITION BY EDUCATED MEN**

10 POINT

20A 45a \$3 00

*According to the resolutions recently passed by the Ladies Dress Reform Club, the undersigned will dispose of their large and varied stock of Unique and Stylish Headgear, together with Ribbons and Ostrich Plumes, at Webster Hall, Massachusetts Avenue, on Friday, Dec. 31, 2034*  
**SALE OF SEASONABLE MILLINERY ARTICLES**

8 POINT

20A 50a \$2 75

*The Roserton & Sleuth Detective Agency is happy to inform managers of railroads and factories who are desirous of reducing their employes wages, it has made many improvements in its methods of getting up and reporting genuine-appearing "outrageous treatment and intimidations of workmen by strikers."*  
**SOCIETIES FOR RELIEVING IMPECUNIOUS MECHANICS**

OTHER SIZES IN PREPARATION

BRADLEY SERIES

---

60 POINT

3A 5a \$8 50

**Typograph**

48 POINT

3A 8a \$6 75

**Latest Design**

36 POINT

4A 10a \$5 00

**History of German  
and English Letter**

24 POINT

5A 16a \$3 50

**Bold characters were used  
in all manuscripts from the  
fifth century to the close of**

## BRADLEY SERIES

18 POINT

8A 25a \$3 25



**WEINHEIM** and Pannartz, of Rome, printed a large Volume entitled **Lactantius** on the first

12 POINT

15A 45a \$3 00

**Aldo Manuccio**, born at Bassano, who succeeded **Christopher Jenson** at Venice, and turned to good account the fonts of Type inherited from the latter also invented the style of Type known as **Italics**

10 POINT

16A 50a \$2 75

The precise time in which the art of printing was discovered by **Laurens** is not ascertained. From data collected it is evident that the first idea must have been suggested about the year 1428 or 1430. This conjecture is strengthened

8 POINT

18A 52a \$2 50

Printing was introduced into America at Mexico by the Viceroy **Mendoza** in 1536. The first book printed was the **Escala espiritual de San Juan Climaco**, of which no copy is known to exist; but the oldest American book now extant is the **Manual de Adultos**, dated 1540. The last four leaves are to be found in an excellent state of

6 POINT

20A 60a \$2 25



THE NAME of the earliest printer in America is a matter of question. **Cambridge, Mass.**, is entitled the distinction of having the first printing press in North America. For this press the colony was mainly indebted to the **Rev. J. Glover**, a nonconformist minister possessed of a considerable estate who had left England to settle among his friends in Massachusetts. Some gentlemen of Amsterdam also "gave towards

42 POINT BRADLEY INITIALS 3A \$3 00; SINGLE LETTER 20 CENTS

54 POINT BRADLEY INITIALS 3A \$4 25; SINGLE LETTER 25 CENTS

**SATANICK SERIES**

72 POINT

4A 5a \$17 00

Mathew

60 POINT

4A 5a \$12 25

for Sin 4

54 POINT

4A 5a \$10 25

Lost 3 Car

48 POINT

4A 5a \$7 75

8 Bold Kick

42 POINT

4A 6a \$7 25

Great People

SATANICK SERIES

---

36 POINT

5A 8a \$5 50

# Market Houses 15 Questions

30 POINT

6A 10a \$5 00

# Engine Destroyed Blazing 6 Home

24 POINT

6A 15a \$4 50

# Sent Through Boston Domestic 4 Nature

18 POINT

8A 25a \$4 00

# Large Vessels Sunk at Anchor The Crews Drowned 89

12 POINT

10A 35a \$3 25

# Muscular Gentleman Exhibits Endurance 6 Breaks Through the Darkest Cloud

SATANICK SERIES

10 POINT

12A 40a \$3 00

**W**HILST as fickle fortune smil'd,  
 Thou and I were both beguil'd.  
 Every one that flatters thee  
 Is no friend in misery.  
 Words are easy like the wind;  
 faithful friends are hard to find.  
 Every man will be thy friend  
 Whilst thou hast wherewith to spend.

8 POINT

15A 50a \$2 75

**W**HEN let not winter's ragged hand deface  
 In thee thy summer, ere thou be distill'd:  
 Make sweet some phial, treasure thou some place  
 With beauty's treasure, ere it be self-kill'd.  
 That use is not forbidden usury  
 Which happies those that pay the willing loan;  
 That's for thyself to breed another thee,  
 Or ten times happier, be it ten for one;  
 Ten times thyself were happier than thou art,  
 If ten of thine ten times refigur'd thee:  
 Then, what could death do if thou should'st depart,  
 Leaving thee living in posterity?  
 Be not self-will'd, for thou art much too fair  
 To be death's conquest, and make worms thine heir.

6 POINT

15A 50a \$2 50

**F**ROM fairest creatures we desire increase,  
 That thereby beauty's rose might never die,  
 But as the ripper should by time decease,  
 His tender heir might bear his memory:  
 But thou, contracted to thine own bright eyes,  
 feed'st thy light's flame with self-substantial fuel,  
 Making a famine where abundance lies,  
 Thyself thy foe, to thy sweet self too cruel.  
 Thou that art now the world's fresh ornament,  
 And only herald to the gaudy spring,  
 Within thine own buduriest thy content,  
 And, tender churl, mak'st waste in niggarding.  
 Pity the world, or else this glutton be,  
 To eat the world's due, by the grave and thee.



LIVERMORE OUTLINE

60 POINT

3A 4a \$8 25

*Presidents*

48 POINT

3A 6a \$6 25

*Clever Works*

36 POINT

4A 10a \$5 25

*Mansion Seekers*

30 POINT

5A 12a \$4 75

*Burning Arguments  
Unconcerned*

24 POINT

6A 18a \$4 25

*Headwear and Strawrim  
Import Cloth Hats*

LIVERMORE SERIES

---

60 POINT

3A 4a \$8 25

*Presidents*

48 POINT

3A 6a \$6 25

*Clever Works*

36 POINT

4A 10a \$5 25

*Mansion Seekers  
Furnished*

30 POINT

5A 12a \$4 75

*Burning Arguments  
Unconcerned*

LIVERMORE SERIES

24 POINT

6A 18a \$4 25

*Headwear and Strawrim  
Import Cloth Hats*

18 POINT

9A 28a \$3 75

*Consignment of Desirable Horses  
Doctor Johnson Stuckup*

12 POINT

15A 50a \$3 25

*Madam Vanity Desires the Pleasure of your  
Company at the Sixteenth  
Birthday Party of her Daughter Helen*

10 POINT

15A 55a \$3 00

*Doctor Skinflint Specially Recommends his Celebrated  
Elbow Grease for Idlers and all  
Old Friends afflicted in the Morning with that*

8 POINT

15A 55a \$2 75

*Melancholic Boys or Love Sick Maidens Troubled with  
Heart Ache can be Thoroughly  
Cured by the use of Madam Rumors Celebrated*

6 POINT

15A 60a \$2 50

*The Duties of the President of the United States are extremely  
disagreeable in many instances  
Sometimes Causing him very much Humiliation*

HARVARD ITALIC

2

30 POINT

6A 12a \$4 25

*Because 64 Wealthy*  
**COUNTRY RULER**

24 POINT

7A 15a \$3 50

*National 132 Conventions*  
**POPULACE INQUIRES**

18 POINT

10A 18a \$3 25

*Thanksgiving 49 Proclamation*  
**INTERCLUB BANQUETER**

14 POINT

16A 26a \$3 00

*Complicated Geometric Problems 48*  
**PATTERN MAKERS INVESTING**

12 POINT

18A 30a \$3 00

**MECHANICS ARTIST DESIGNATOR**  
*Numerous Scientific Batteries*

*Of these testimonies, those only are de-  
serving of attention which are professed  
to be based on actual inspections \$186*

**HARVARD ITALIC**

10 POINT

20A 34a \$2 75

**ELECTROTYPERS GRAND ASSOCIATION**

*Copperplate Avenue 74th Street*

*The press manufacturers have invented devices which would make the ancient printer stare in blankest amazement and wonder what his first*

9 POINT

20A 34a \$2 50

**ACCUMULATING MEDIÆVAL MANUSCRIPTS**

*Remarkable Collection Secured*

*Never in the history of printing has there been such a marked advance in the improvement of material used by printers in the art, as that which the last decade has witnessed. Writers are \$1234567890*

8 POINT

24A 36a \$2 50

**WITNESSING A GREAT SQUADRON MANŒUVER**

*Decidedly Interesting Manual Training*

*General Blackburn, it is reported, was slightly wounded in the forearm. This battle lasted several hours and heavy losses are reported on both sides. Great \$1234567890*

6 POINT

32A 42a \$2 25

**DOUBTFUL REGARDING A CADETS EFFICIENCY WITH ROD**

*Beautiful Speckled Denizens Quickly Captured*

*Springtime with glorious mornings tempts former residents of the old farming districts back to their childhood haunts where they again renew their youth in happy memories of the past £1234567890*

**CUSHING SERIES**

12 POINT

14A 8A 36a \$5 00

THE PRINTING INVENTION has always been recognized by educated men as a subject of importance: there is no mechanical art, nor are there any of the fine arts, about whose early history so many books have been written. The subject is as mysterious 123456

ABCDEFGHIJKLMN O P Q R

10 POINT

16A 10A 40a \$4 50

THE INVENTION OF PRINTING has always been recognized by educated men as a subject of importance: there is no mechanical art, nor are there any of the fine arts, about whose early history so many books have been written. The subject is as mysterious as it is inviting. There is an unusual degree of obscurity about 1234567

ABCDEFGHIJKLMN O P Q R S T U V W

8 POINT

20A 12A 44a \$4 00

THE INVENTION OF PRINTING has always been recognized by educated men as a subject of importance: there is no mechanical art, nor are there any of the fine arts, about whose early history so many books have been written. The subject is as mysterious as it is inviting. There is an unusual degree of obscurity about the origin of the first printed books and the lives and 123456789

ABCDEFGHIJKLMN O P Q R S T U V W X Y Z

6 POINT

20A 12A 50a \$3 50

THE INVENTION OF PRINTING has always been recognized by educated men as a subject of importance: there is no mechanical art, nor are there any of the fine arts, about whose early history so many books have been written. The subject is as mysterious as it is inviting. There is an unusual degree of obscurity about the origin of the first printed books and the lives and works of the early printers. There are records and traditions which cannot be reconciled of at least three distinct inventions of printing. Its early history is entangled with a controversy about rival 1234567890

ABCDEFGHIJKLMN O P Q R S T U V W X Y Z

## CUSHING ITALIC

12 POINT

20A 50a \$3 94

*THE INVENTION OF PRINTING* has always been recognized by educated men as a subject of importance: there is no mechanical art, nor are there any of the fine arts, about whose early history so many books have been written. The subject is as mysterious 12345

10 POINT

28A 80a \$3 80

*THE INVENTION OF PRINTING* has always been recognized by educated men as a subject of importance: there is no mechanical art, nor are there any of the fine arts, about whose early history so many books have been written. The subject is as mysterious as it is inviting. There is an unusual degree of obscurity about 12345678

8 POINT

28A 80a \$3 00

*THE INVENTION OF PRINTING* has always been recognized by educated men as a subject of importance: there is no mechanical art, nor are there any of the fine arts, about whose early history so many books have been written. The subject is as mysterious as it is inviting. There is an unusual degree of obscurity about the origin of the first printed books and the lives and works of the early 123456789

6 POINT

28A 80a \$2 60

*THE INVENTION OF PRINTING* has always been recognized by educated men as a subject of importance: there is no mechanical art, nor are there any of the fine arts, about whose early history so many books have been written. The subject is as mysterious as it is inviting. There is an unusual degree of obscurity about the origin of the first printed books and the lives and works of the early printers. There are records and traditions which cannot be reconciled of at least three distinct inventions of printing. Its early history is entangled with a controversy about rival inventors which has lasted for more than three 1234567890

**WAVERLY CIRCULAR SERIES**

12 POINT

Card Font 10A 20a \$3 00  
Circular Font 30A 140a \$14 25

Knowing that the hand intelligently  
educated and employed, has brought  
man from barbarism, and makes his  
position superior to that of animals  
not possessing this useful appendage

REGULAR MEMBERS

10 POINT

Card Font 12A 24a \$3 10  
Circular Font 36A 150a \$13 85

That my hands, and those of all others  
placed under my charge, shall be fully  
trained in some handicraft beneficial to  
the race, and that I will on all occasions  
endeavor to keep them ever employed

FAITHFULLY COVENANT

\$1234567890

8 POINT

Card Font 14A 30a \$3 00  
Circular Font 40A 160a \$10 85

Whereas, on the ninth instant Peter Thompson  
was found near the Castles of Indolence, sitting  
astride a fence, and there remained whittling a  
pine stick for a period of three hours; therefore  
it was resolved, that he is hereby expelled from  
this society, with the privilege of reinstatement

REMARKABLE TRANSACTION

\$1234567890



APOLLO SERIES

15

18 POINT

9A 18a \$4 00

Brings Sweetest Melody  
Operatic Season  
DELIGHTFUL FLOWERS

12 POINT

12A 28a \$3 50

Look at Nature. She never wearies  
of saying over her pater-noster. In  
the crevices of the Cyclopean walls,  
on the mounds that bury huge cities.  
NATURE NEVER WEARIES

10 POINT

14A 32a \$3 25

One of the most popular legends in Brittany  
is that relating to an imaginary town called  
Is, which is supposed to have been swal-  
lowed up by the sea at some unknown time.  
According to them, the tips of the spires 53  
A LEGEND OF BRITTANY

8 POINT

20A 44a \$3 00

The Universal Publishers' Association is hereby pleased to  
announce to all literary aspirants throughout the World  
that it has perfected arrangements with an unlimited num-  
ber of indiscriminative and noncritical book devourers,  
whereby it is enabled to unload tons of their efforts \$1234  
DESIRABLE FOR LETTER CIRCULARS

**CHELSEA CIRCULAR**

—12—

18 POINT

9A 30a \$5 00

Stone Buildings bordering  
the Lake Front are falling

FLOWERY LAWN

12 POINT

12A 40a \$3 00

Ambitious Young Men entering upon  
Public Careers should avoid Boodlers

POLITICAL COMPLEXION

10 POINT

18A 60a \$3 50

Precocious Youths who display Remarkable  
Talents should receive every Opportunity  
which Parents can possibly afford tending

EDUCATE YOUNG SCHOLARS

8 POINT

24A 80a \$4 50

Good Punctuation is recognized as a Necessary  
Factor by good Writers, and Printers spend their  
Lives in attempting to elucidate the meanings of

MOUNTAIN SCENERY PICTURED

6 POINT

24A 80a \$4 00

Good Punctuation is recognized as a Necessity by Good  
Writers, and Printers spend their Lives in weary attempts  
at elucidating the meanings of Paragraphs or Sentences  
Which they compose or correct; in trying to show their

PHOTOGRAPH SPLENDID SUSQUEHANNA

ISABELLA SERIES

---

18 POINT

5A 20a \$4 15

## Display of Paris Styles

All requirements in quality and cheapness are embraced in our Stock of Fashionable Millinery

12 POINT

8A 32a \$3 80

### Special Circular No. 23,847

In pursuance of Resolution adopted at the March meeting, feminines will hereafter, when visiting places of amusement, refrain from wearing towering headgear

9 POINT

10A 35a \$3 45

### Sale of Seasonable Hats and Trimmings Sacrifice of Entire Stock

According to resolutions recently passed by the Ladies' Dress Reform Club, the undersigned will dispose of their large and varied stock of Unique and stylish Headgear, together with Ribbons and Ostrich Plumes, on Friday, December 24, 1965.

Collins & Jackson

**IVY SERIES**

—12—

12 POINT

10A 52a \$4 40

Gutenberg Invented Printing

Four hundred years have now elapsed, a period marking the ascendancy of the world from comparative obscurity to its wonderful attainments of the present day, yet the man who first lifted the mantle of darkness that clouded the mental vision of that early age still lives within our memory, although 234

---

**IVY SERIES No. 2**

—12—

12 POINT

10A 52a \$4 40

Propose Anniversary Ceremony

The corporation of Mayence has decided to celebrate the anniversary of the birth of John Gutenberg, which occurred about four hundred years ago, with all the pomp and splendor due the memory of the German inventor of the art of printing. The celebration will attract some notice from countries which dispute prior 567

PROGRAM SERIES

12

24 POINT

6A 12a \$3 65 4A \$1 20

DUCK POND Farms

18 POINT

8A 16a \$3 40 6A \$1 05

MORE \* SPRING \* Poets

16 POINT

12A 24a \$3 60 8A \$1 00

FRIENDS JEST Sometimes

12 POINT

18A 36a \$3 40 12A \$0 95

246 HOME GROWN String Beans

10 POINT

24A 48a \$3 40 18A \$1 00

Diamonds Sparkling LIKE MAIDEN EYES  
\*THUNDER ☆ STORMS\*

8 POINT

24A 48a \$2 80 18A \$0 85

Editors Frowned While READERS WROTE POETRY  
BEAUTIFUL SPRING COSTUMES 12345

6 POINT

32A 64a \$2 90

Unscrupulous Counterfeiters Hoodwink Sleeping Detectives  
⇒THEREBY MAKING ESCAPE POSSIBLE⇐

**GROTESQUE No. 120**

30 POINT

6A 12a \$4 40

Monster Rotaries

24 POINT

10A 20a \$4 15

20a \$2 20

Overthrow Masterpiece

HERMETRIC

18 POINT

10A 20a \$2 90

20a \$1 50

Marquette Great Explorers

ENTHUSIASTIC

12 POINT

12A 24a \$2 10

24a \$1 10

Generations Manifesting Agnostically

CIRCUMVENTION

10 POINT

18A 36a \$2 45

36a \$1 25

Conglomerated Longshoremen Outgenerated

REQUISITE EDUCATION

8 POINT

18A 36a \$1 90

36a \$0 95

Demonstrated Unanimous Utahs Consent Unequivocally

OLD GLORY FORTY FIVE STARS

**FANCY GROTESQUE**

12

30 POINT

6A 12a \$4 65

Retrieve Fortune

GRACES

24 POINT

10A 20a \$3 95

20a \$2 10

Monumental Displaying

GNOMES 45

18 POINT

10A 20a \$2 90

20a \$1 50

Mermonie Valiant Captured

82 CHAISONETTE

12 POINT

12A 24a \$2 20

24a \$1 15

Monstrous Atrocity Here Perpetrated

Dubious 87 Authority

HONOR GOLDEN SHIELD

**INCLINED PROGRAM**

24 POINT

6A 12a \$4 00

SHINED Brackets

18 POINT

8A 16a \$3 60

GREAT \* Brownies 8

16 POINT

10A 20a \$3 50

PRINTERS Discourteous

12 POINT

18A 36a \$3 60

67 FOUR BLACK Porous Plasters

10 POINT

18A 36a \$2 80

Debating Attorneys Close Arguments  
\*CUTLERY <sup>And</sup> NOTIONS\*

8 POINT

24A 48a \$3 10

Creating Intense Excitement Over Venezuela  
853 TESTED SCIENTIFIC METHODS

6 POINT

32A 64a \$3 35

Distracted Mothers Weeping Over Dissipated Maidens  
~REDUCING INCREASED EXPENSES~



**CIRCULAR GOTHIC No. 120**

12

24 POINT

Card Font 10A 20a \$3 20  
Circular Font 10A 40a \$4 90

*Enthused Audiences Convened*  
*REFUSING DONATION*

18 POINT

Card Font 12A 24a \$2 65  
Circular Font 12A 48a \$4 05

*Mariners Encounter Gales Unknown*  
*TERRIBLE 42 EXPERIENCE*

12 POINT

Card Font 18A 36a \$2 45  
Circular Font 18A 108a \$5 05

*Political Doctrines Ignored Through Baseness*  
*MUNICIPAL FUNCTION IMPAIRED 42*

10 POINT

Card Font 24A 48a \$2 45  
Circular Font 24A 144a \$5 15

*Heterogeneous Conglomeration Laboriously Attenuated*  
*Scientific Experiments Unfruitful*  
*LEARNED PROFESSORS DESPAIRING 653*

8 POINT

Card Font 24A 48a \$2 10  
Circular Font 24A 144a \$4 40

*Beneficence Characterizes Most American Mercantile Plutocrats*  
*Libraries Donated Commonwealths*  
*246 DESPONDENT WORKERS DEPLORE CONTEST*

TRISTAN ITALIC

30 POINT

4A 4A 25a \$8 00

4A 25a \$6 15

*Tinckerville Over the River 12*

24 POINT

5A 5A 30a \$7 50

5A 30a \$5 40

*34 Things of Beauty, Joy Forever  
United States of America*

18 POINT

6A 6A 40a \$6 75

6A 40a \$5 25

*Solicit your Company at the Wedding 56  
Mr. & Mrs. Henry Brown*

12 POINT

10A 50a \$4 35

*Onward, Christian Soldier, March as to War  
In the Days of Auld Lang Syne*

10 POINT

10A 50a \$3 60

*Large Importation of Dry Goods, Jewelry, Hardware, etc.  
United States District Court for Missouri*

8 POINT

12A 60a \$3 60

*The Lowing Herd winds Slowly o'er the Lea, the Weary Plowman  
Curfew Tells the Knell of Parting Day  
\$1234567890*

GROLIER SERIES

24 POINT WITH 36 POINT INITIALS

3A 4A 20a \$7 50

*Enrollment of Members*

*Promising that our hands shall be  
trained in some useful Handicraft*

18 POINT WITH 30 POINT INITIALS

3A 6A 30a \$6 90

*Important Business Meeting*

*Expulsion of Member*

*Whereas, Peter Fiddlehandle was found  
whittling a stick; therefore be it Resolved*

12 POINT WITH 24 POINT INITIALS

4A 8A 40a \$5 60

*Report of Committee on Extension of Labor*

*Preparations for Future Activity*

*In the prosecution of our labors we discover many  
persons lying under trees expecting fruit to drop into  
their mouths. We recommend that a number of our  
roundsmen be sent to stir them up to a sense of duty*

**FRENCH SCRIPT**

54 POINT

3A 9a \$12 20

*Sound Horse  
Auction*

44 POINT

4A 12a \$11 25

*French Costumes  
Bridemaids*

36 POINT

5A 14a \$10 75

*Renovate Mansion  
Ornamentation*

FRENCH SCRIPT

28 POINT

6A 18a \$8 90

*Great Exhibit of Notions  
and 16th Century Ware*

22 POINT

7A 22a \$7 25

*M<sup>iss</sup> Lydia Thompson desires  
four Students in Dressmaking*

18 POINT

8A 24a \$6 00

*Chiropodist and Manicure Expert  
publicly announces his Removal to  
the Centennial Apartment House*

14 POINT

9A 30a \$5 00

*The Seventy-eighth Annual Convention  
of Disgusting Busybodies meet to determine  
Inquisitive Questions for ensuing quarter*

12 POINT

10A 35a \$4 00

*Handsome and Attractive Suburban Residences for  
wealthy manufacturers and retired farmers maintained at  
a Yearly Expenditure of Fourteen Thousand Dollars*

SHEPARD SCRIPT

—15—

48 POINT

4A 8a \$8 00

Choral Societies

36 POINT

5A 12a \$6 75

Musicians Instrument  
Entertainments

24 POINT

6A 18a \$4 75

Beautiful Maiden Accepts Escort  
Dancing *and* Luncheon

18 POINT

8A 18a \$3 75

Hymeneal Altar Catches Unwary Admirer  
— Lovesick Damsels Paradise —

1 2 3 4 5 6 7 8 9 0

MASTER SCRIPT

36 POINT

3A 4A 12a \$11 90

Trumpet Bounded  
Horsemen

24 POINT

3A 5A 20a \$8 40

Glorious May Festival  
Grand Display

18 POINT

3A 5A 25a \$6 30

Handsome Women Infatuated  
Charming Footwear

12 POINT

10A 50a \$5 20

Beautiful Roadway to Permanent Welfare  
Greatest Anticipation Realized

1 2 3 4 5 6 7 8 9 0

CIRCULAR SCRIPT

24 POINT

10A 50a \$18 65

We have determined  
to devote our fortunes  
and the labor of life to  
the benefit of mankind

18 POINT

10A 50a \$12 20

Rubhard Lively, M. D.

Dear Sir: I am troubled  
with loose purse strings. If  
you can cure this disease, you  
will gratify Yours truly,  
Gregory Lackthrift

12 POINT

10A 50a \$7 00

Gregory Lackthrift.

Dear Sir: Having carefully studied  
all the symptoms of your case, I have  
forwarded a package of Elbow Grease.  
If diligently applied from 7 a. m. to 6  
p. m., daily, it will relieve your ailment  
Rubhard Lively, M. D.



---

**MANUSCRIPT No. 1**

24 POINT

6A 22a \$7 00

*Missionary Societies  
Will be formed in all large  
cities about April 24*

16 POINT

10A 44a \$6 00

*The meetings of the Societies will be held  
monthly instead of quarterly and at such  
place as specified on circulars sent forth*

---

**MANUSCRIPT No. 2**

24 POINT

6A 20a \$7 00

*Randolf Drug Co.  
Intend opening a new  
store at 89 Elm street*

16 POINT

10A 40a \$6 00

*Previous to vacating their store  
at 56 Ring street the entire stock  
of Tooth Brushes will be sold out*

PEN TEXT SERIES

36 POINT

3A 3A 10a \$9 00

Sound Money

30 POINT

3A 3A 20a \$8 40

Among the Violets

20 POINT

3A 3A 20a \$5 20

A Return From 280 Sands

18 POINT

4A 4A 25a \$5 00

When Death Wraps this Form

14 POINT

4A 4A 25a \$4 70

The Expiring Twilight Glides into 29

12 POINT

6A 6A 36a \$4 35

When Birds Chant 972 and Tuneful Notes

10 POINT

8A 8A 50a \$4 50

Staid Old English Town Heard John Gilpin's Ride

8 POINT

20A 60a \$3 60

I Like the Weather when not Rainy 285 if not Good Coal Fire

PEN TEXT No. 2

11

48 POINT

3A 6a \$8 20

*Sweet Marie*

36 POINT

4A 12a \$6 75

*Dark Pathless Forest*

24 POINT

6A 20a \$5 40

*The Clear Blue Sky Looks*

20 POINT

6A 20a \$4 10

*May Only Bright Rays Cheer*

18 POINT

8A 25a \$3 90

*Loss of Hope Spoils our Longevity 389*

14 POINT

8A 25a \$3 10

*Even Parents are at times Shortsighted 597*

12 POINT

12A 36a \$3 00

*With Features Fair also Dusky Hair, but in her Sadness*

10 POINT

16A 50a \$2 90

*There is no Daylight that Sees Half the Wickedness on Which Three*

STYLUS SERIES

24 POINT

6A 14a \$5 60

*Notice is hereby given that a sweeping reduction will be made in the Millinery Store*

18 POINT

8A 20a \$5 05

*Having Cut our Wisdom Teeth, we are satisfied that we have ability of high order, and request you and your friends to examine our superb stock*

12 POINT

12A 32a \$3 90

*The last Earthquake nearly shook us out of our Boots and the Goods off the Shelves. The stock is uninjured; but rather than rearrange it we will allow it to go at ninety per cent. discount. Come early and often and take advantage of this grand offer to get one dollar's worth of goods for a dime*

9 POINT

12A 32a \$2 70

*Our Formal Reception takes place at the Almshouse. We close our business this morning with the well-wishes of the Sheriff, an immense stock of experience, some tattered clothes, no money, and many creditors; but our Wisdom Teeth are still in fine condition, and in the future we shall give them exercise on such alimentary substances as may be doled out to us by the municipal authorities*

## STYLUS No. 2

24 POINT

6A 14a \$5 00

Printers should not stoop to pick up a Type that has dropped on the Floor, as it is liable to disorder clothes

18 POINT

8A 20a \$4 50

Let the serviceable letter lie where it falls, under foot, and at Night it can all be picked up at once, which is a great saving of time. If the Type looks bad from being walked on, the Proofreader will discover it

12 POINT

12A 32a \$4 00

Never waste Time in Alaning down a Form until it is securely locked up; ten to one it will Spring up again when you tighten the Quoins. When you commence to tighten a Quoin never leave it until you have driven it home. Some skillful printers tighten the Quoins with their fingers and afterward with the shooting stick

CHICAGO SCRIPT

36 POINT

Card Font 3A 8a \$6 00  
Circular Font 5A 25a \$15 30

Forward Throris/  
Enchant  
Misconstrued

24 POINT

Card Font 4A 12a \$4 70  
Circular Font 8A 36a \$11 75

Thriners Grand Conclave/  
Answer Present/  
Th th <sup>nd</sup> ("qu") & \$253

18 POINT

Card Font 6A 16a \$4 30  
Circular Font 12A 48a \$10 75

Resumed Mercantile Transaction/  
Condemned Insurance/  
Momentous Questions arise

SWEDISH ACCENTS ARE CAST FOR ALL SIZES OF THIS SERIES  
FIGURES AND LOGOTYPES WITH ALL SIZES

SPINNER SCRIPT

12

32 POINT

Card Font 3A 8a \$4 80  
Circular Font 5A 25a \$11 75

Grand Church Social

24 POINT

Card Font 4A 12a \$4 75  
Circular Font 8A 50a \$12 50

Fair Dealer & Co invite your  
attendance at their Fall Sale

24 POINT NO. 2

Card Font 4A 12a \$4 75  
Circular Font 8A 60a \$12 50

A Merry Christmas and a  
Happy New Year to you all

18 POINT

Card Font 6A 16a \$4 35  
Circular Font 12A 60a \$10 00

Yourself and company are invited to be  
present at our Grand Masque Ball.

12 POINT

Card Font 6A 25a \$3 25  
Circular Font 15A 75a \$8 00

The Eleventh Annual Meeting of the Southwestern  
Trotting Association will be held next Wednesday  
afternoon at 2.30 o'clock, at the Breeder Hotel.

ALFERETA SERIES

12

36 POINT

4A 8a \$6 00

Heroic Soldier  
Mobilized

30 POINT

5A 10a \$5 25

National Evolution  
Advantageous

24 POINT

6A 12a \$4 50

Conscription Recruiting  
Reconsideration

18 POINT

8A 16a \$3 50

Western Regiments Marched  
Undaunted Activity

12 POINT

8A 30a \$2 75

Antagonists Encounter Numerous Barriers  
Invading Companies Repulsed

1 2 3 4 5 6 7 8 9 0



**QUINCY SCRIPT**

48 POINT

3A 6a \$6 00

Patriotic Cubans

36 POINT

4A 9a \$5 00

Havana 246 Orators

24 POINT

5A 16a \$4 25

Associations Literary Receptions  
Generally Broken Through 1432

**SKINNER SCRIPT**

18 POINT

7A 22a \$4 00

Covent Garden Promenade Concerts  
Aristocratic Families Represented  
Magnificent String Quartet \$1654

12 POINT

10A 28a \$3 30

The modesty of C. W. Skinner, Esq., Hartford, Conn., a member of the noble printing fraternity, leads him to protest against this attempt to imitate his handwriting. Kindly justify our choice by your appreciation . . . 1234567

**MAGNOLIA SCRIPT**

24 POINT

7A 20a \$7 00

*Springtime Excursions*  
*Monday and Tuesday mornings*  
*commencing on April 30.*

**AUTOGRAPH SCRIPT**

24 POINT

7A 20a \$8 00

*Duncan Brothers,*  
*Fine Merchant Tailors,*  
*Suits to Order, \$24.*

**LITHO**

18 POINT

Card Font 8A 16a \$3 15  
Circular Font 32A 112a \$16 75

The Directors take great pleasure in  
stating that the Second Annual Fair  
of the Elizabeth Agricultural Society

ḥ ṃ ṇ THESE LETTERS ARE MORTISED, NOT KERNED ṛ ṿ ẉ

**CLEVELAND SCRIPT**

24 POINT

Card Font 4A 16a \$4 50  
Circular Font 8A 32a \$8 50

Regular Monthly Banquet  
Members Invited

---

**CARPENTER SCRIPT**

30 POINT

Card Font 4A 16a \$6 50  
Circular Font 8A 32a \$12 50

Chicago, August 26<sup>th</sup>  
Homer Martin

22 POINT

Card Font 4A 16a \$4 50  
Circular Font 8A 32a \$8 50

Annual Statements Received  
Millinery Emporium

---

**HOYT SCRIPT**

30 POINT

Card Font 3A 9a \$4 75  
Circular Font 4A 18a \$8 85

Artistic Printers  
Ornament

**OLD STYLE SCRIPT**

30 POINT

Card Font 3A 9a \$5 00  
Circular Font 6A 18a \$9 00

*In the 10th Class is catalogued the books of Poems by Charles Bunsbey, being made very conspicuous by an*

24 POINT

Card Font 3A 10a \$4 50  
Circular Font 6A 20a \$8 00

*Estimated as a compound of all that is most noble in man, corporeal strength united to unusual symmetry and comeliness of person, Washington is without a parallel in history*

---

**OLD STYLE SCRIPT**

---

15

18 POINT

Card Font 4A 12a \$3 50  
Circular Font 8A 24a \$6 00

*The poetical nature of Columbus is seen in all his writings and throughout all his actions, and it spread a golden and glorious world about him, and tinged all things with its gorgeous colors. But also did it betray him into visionary speculation which subjected him to*

12 POINT

Card Font 5A 16a \$3 00  
Circular Font 10A 32a \$5 00

*The poetical temperament of Columbus is seen in all his writings, and throughout all his actions, and it spread a golden and glorious world about him, and tinged all things with its gorgeous colors. But it betrayed him into visionary speculation which subjected him to the sneers and cavillings of men of cooler and safer but more grovelling minds. Such were the conjectures formed on the coast of Paria; about the form of the terrestrial paradise; about the mines of Ophir, in Hispaniola, and the Aurea Chersonesus, in Teragua; and such was the heroic scheme of the*

**ROYAL SCRIPT**

30 POINT NO. 1

15

Card Font 4A 10a \$5 00  
Circular Font 7A 20a \$9 00

*The little eyes that never  
knew Light other than of  
dawning skies, what new  
life Now lights up Anew  
the little Eyes? No storm*

30 POINT NO. 2

Card Font 4A 12a \$5 00  
Circular Font 7A 22a \$9 00

*We know, can change the blue  
soft heaven that Haply death  
Descries; no tears, like these  
in ours, bedew the little Eyes  
Lighten Earth to Paradise*

## ROYAL SCRIPT

15

24 POINT NO. 1

Card Font 4A 10a \$4 50  
Circular Font 8A 20a \$7 50

*The long lines of red and gold  
in the Sky, and the Glorious  
track of the descending sun, were  
all divinely calm. Upon the  
purple tree-tops far away, and  
on the Green heights nearer at*

24 POINT NO. 2

Card Font 4A 12a \$4 50  
Circular Font 8A 22a \$7 50

*Hand, up which the Shades were  
slowly Creeping, there was an equal  
hush. Between the real landscape  
and its shadow in the water there was  
no division; both were so Clear and  
Untroubled, yet mysteriously quiet*

## ROYAL SCRIPT

18 POINT

Card Font 4A 12a \$3 50  
Circular Font 8A 24a \$6 00

*The time I've lost in wooing, in watch-  
ing and pursuing the Light that lies in  
womans Eyes, has been my heart's un-  
doing. Though Wisdom oft has fought  
me, I scorned the love she Brought me*

12 POINT

Card Font 5A 16a \$3 00  
Circular Font 10A 32a \$5 00

*My only books were womans looks, and Folly's all  
they've taught me. Her smile when Beauty granted, I  
hung with gaze enchanted, Like him the Sprite whom  
Maids by night oft meet in glen that's haunted. Like  
him, too, Beauty won me but while her eyes were on me;  
If once their ray was Turned away, Oh! winds could*

10 POINT

10A 32a \$4 50

*Not outrun me. And are those follies going? And is my  
proud heart growing Too cold or wise for Brilliant eyes again  
to set it Glowing? No, vain, alas! the endeavor From bonds  
so sweet to sever; poor Wisdom's chance against a glance is  
now as weak as ever. Poetical Works of Sir Thomas Moore  
Fourscore, like twenty, has its tasks and toys; in Earth's  
wide school-house all are Girls and Boys. O. W. Holmes*



SPENCERIAN SCRIPT No. 2

40 POINT

Card Font 2A 5A 25a \$20 75  
Circular Font 4A 10A 50a \$41 50

*Lightning Movement*

28 POINT

Card Font 3A 8A 30a \$16 05  
Circular Font 6A 16A 60a \$32 05

*Merchants Engage Strangers  
Orchestra Changed*

22 POINT

Card Font 3A 9A 50a \$14 05  
Circular Font 6A 18A 100a \$28 05

*Invite to your Fifth Piano Concert  
Mrs Joe Quinton  
Monday, January 4th, 1896.*

16 POINT

Card Font 3A 9A 50a \$10 35  
Circular Font 6A 18A 100a \$20 65

*Wednesday and Friday in the Evenings  
University Examiners  
Trocktown, County of Classic Lore.*

**SPENCERIAN SCRIPT**

4 ———

60 POINT

3A 9a \$17 60

*Horticultural  
Society  
Reorganized.*

40 POINT

Card Font 5A 25a \$20 00  
Circular Font 10A 50a \$40 00

*Cooking Academy  
Watcherville  
Fourth Season.*

SPENCERIAN SCRIPT

28 POINT

Card Font 8A 30a \$14 40  
Circular Font 16A 60a \$28 75

Monday, September 8th, 1896

your presence on

Dr. & Mrs. Browne

22 POINT

Card Font 9A 50a \$13 65  
Circular Font 18A 100a \$27 25

Hereby inform their friends and

Summer Clothing

Messrs. Clothall & Pittall

16 POINT

Card Font 9A 50a \$9 15  
Circular Font 18A 100a \$18 30

We take pride in presenting to Printers this

unsurpassed design of

Script, which we call Spencerian

ORNAMENTED CAPITALS FURNISHED WHEN SO ORDERED

**STEELPLATE SCRIPT**

30 POINT NO. 1

15

Card Font 4A 10a \$5 00  
Circular Font 7A 20a \$9 00

Beautiful Crimson Roses  
Sprung from Grace of God  
Daughter of the Regiment  
Loved Handsome Soldiers  
Promises and Fulfillments

30 POINT NO. 2

Card Font 4A 12a \$5 00  
Circular Font 7A 25a \$9 00

Among New England Hills  
Troubles are Mostly Bubbles  
Shows Simple, Childlike Faith  
Recollection Exceedingly Tender  
Time is the Cradle of all Hope

**STEELPLATE SCRIPT**

15

24 POINT NO. 1

Card Font 4A 12a \$4 00  
Circular Font 8A 22a \$7 00

*Floating thus on Wings Ethereal  
Macbeth Questioning the Hags  
Lear Rave Amid the Tempest  
Revere Immortal Shakespeare*

24 POINT NO. 2

Card Font 4A 14a \$4 00  
Circular Font 8A 28a \$7 00

*Evil is Wrought by Want of Thought  
Our Haunted Chambers of the Night  
To-day a King, To-morrow Nothing  
Beauty and Folly to Join Company*

12 POINT

Card Font 5A 16a \$3 00  
Circular Font 10A 32a \$5 00

*There is a Tide in the Affairs of Men Which  
Taken at the Flood, Leads on to Fortune; But  
Omitted, all the Voyage of their Life is Bound  
In Shallows and in Miseries. W. Shakespeare  
Hope Springs Eternal in the Human Breast*

**BOSTON SCRIPT**

60 POINT

3A 8a \$15 00

*Bostonian*

*Dew*

*Masked*

48 POINT

4A 10a \$12 00

*Dollar Wine*

*Broker*

*Encouraged*

**BOSTON SCRIPT**

2

36 POINT

5A 15a \$10 00

*National Organizer*  
*Counterbalance*

24 POINT

Card Font 3A 8a \$3 00  
Circular Font 7A 20a \$8 00

*Elaborate Weekly Banquet*  
*Praised Gold 85*  
*Solid Banker Retires*

18 POINT

Card Font 3A 10a \$2 00  
Circular Font 9A 25a \$6 00

*Eastern Doctors Render Good Service*  
*Expressions of Gratitude*  
*Opening Exercises Northern Seminary*

*A M N W*

*These handsome extra Capitals to the Boston Script are put up separately, and are furnished when desired at the following prices: 48 Point, \$1.00; 36 Point, 75 cents; 24 Point, 75 cents; 18 Point, 50 cents.*

LADIES' HAND SCRIPT

32 POINT

Card Font 3A 8a \$4 50  
Circular Font 5A 25a \$10 00

*Northern Election Districts*  
*Roman Protest*  
*Charitable Institution*

24 POINT

Card Font 4A 12a \$4 00  
Circular Font 8A 50a \$10 90

*Historical Questions Create Debates*  
*Numbered Contractors*  
*Printed Embossed Notices \$123*

18 POINT

Card Font 6A 16a \$3 75  
Circular Font 10A 75a \$9 00

*Statesmen Visited Celebrated Balmoral Gardeners*  
*Democratic Convention*  
*Honorable Blacksmith Methodical*



LADIES' HAND SCRIPT No. 2

—12—

32 POINT

Card Font 3A 8a \$4 75  
Circular Font 5A 25a \$10 80

Round House Burned  
Dark Horse.  
Gentlemen Friends

24 POINT

Card Font 4A 12a \$4 50  
Circular Font 8A 50a \$12 55

Abhors Foreign Missionaries  
Unlimited.  
5432 Secure Consent

18 POINT

Card Font 6A 16a \$3 75  
Circular Font 10A 75a \$10 75

Darkies Render Choice Southern Melodies  
Turkish harems Endowed  
Widow Released Faithless Bachelor

TITLE SCRIPT

48 POINT

4A 12a \$12 10

Bankers Combine  
Diamonds.

32 POINT

Card Font 3A 8a \$4 75  
Circular Font 5A 25a \$10 50

Ancient Times Precious  
Societies  
Predestination \$1853

24 POINT

Card Font 4A 12a \$4 00  
Circular Font 8A 50a \$11 45

Intoxicated Bohemians Humorous  
Money Advanced  
Centennial Anniversaries.

NOVELTY SCRIPT

15

72 POINT

3A 4a \$16 00

Reports

60 POINT

3A 5a \$11 05

Chaplain

48 POINT

3A 6a \$9 00

South Road

36 POINT

4A 8a \$7 25

Young Dreamer

24 POINT

5A 12a \$5 25

Singing English Hymn

18 POINT

5A 16a \$4 00

Childhood's Happy Recollection

**VENETIAN SERIES**

12

18 POINT NO. 122

Card Font 10A 50a \$6 15  
Circular Font 20A 100a \$12 30

*The Invention of Printing has always been recognized by educated men as a subject of importance 893*

18 POINT NO. 121

Card Font 10A 50a \$6 00  
Circular Font 20A 100a \$12 00

*The Invention of Printing has always been recognized by educated men as a subject of importance 254*

12 POINT NO. 122

Card Font 10A 50a \$3 25  
Circular Font 20A 100a \$6 50

*The Invention of Printing is recognized by educated men as a subject of very great importance; there are arts about whose 85*

12 POINT NO. 121

Card Font 10A 50a \$3 05  
Circular Font 20A 100a \$6 10

*The Invention of Printing has always been recognized by educated men a subject of great importance; there is no mechanical art 1856*

10 POINT NO. 120

Card Font 12A 70a \$4 05  
Circular Font 24A 140a \$8 10

*The Invention of Printing has been recognized by educated men as a subject of importance; there is no mechanical art, nor are there any of the fine arts about whose early history so many books have 2485*

**CIRCULAR ITALIC No. 120**

12

24 POINT

10A 50a \$6 10

*The Invention of Printing has ever been recognized by people of education as a subject of 42*

18 POINT

10A 50a \$4 65

*The Invention of Printing has ever been recognized by educated people as a subject of some importance 24*

12 POINT

18A 100a \$5 40

*The Invention of Printing has ever been recognized by educated men as a subject of importance; there is no mechanical 356*

10 POINT

24A 140a \$5 95

*The Invention of Printing has been recognized by educated men as a subject of importance, for there is no mechanical art about which the 784*

8 POINT

32A 200a \$6 35

*The Invention of Printing has ever been recognized by all men of education and culture as a subject of vast importance; there is no mechanical art about whose history so many books have*

**LAW ITALIC No. 120**

12

12 POINT

Card Font 9A 25a \$2 10  
Circular Font 18A 100a \$6 60

*The Invention of Printing has ever been recognized by educated men as a subject of importance; there is no*

10 POINT

Card Font 12A 35a \$2 30  
Circular Font 24A 140a \$7 40

*The Invention of Printing has ever been recognized by educated men as a subject of importance; there is no mechanical*

8 POINT Card Font 16A 50a \$2 50  
Circular Font 32A 200a \$8 05

6 POINT Card Font 16A 50a \$2 00  
Circular Font 32A 200a \$6 70

*The Invention of Printing has been recognized by educated men as 65*

*The Invention of Printing has ever been recognized by educated men as a subject of vast importance; 12345*

**Copper Alloy Fine-Dot Leaders**

12

These are used as a substitute for Dotted Brass Rule, and save the time spent in justification. Made on 6, 7, 8, 9, 10, 11 and 12 Point bodies. When ordering, state the type (if our make) they are required to line with, or send cap "H" or lower-case "m." The following examples show Fine-Dot Leaders lining with 10 Point Law Italic No. 122 and 8 Point Law Italic No. 120:

10 POINT LAW ITALIC NO. 122 IN COMBINATION WITH FINE-DOT LEADERS

*You.....are hereby commanded to take.....in the said.....*

8 POINT LAW ITALIC NO. 120 IN COMBINATION WITH FINE-DOT LEADERS

*A Court of.....will be held in the town of.....on May 10th.....*

6 Point	Per pound	\$0 64	9 Point	Per pound	\$0 48	12 Point	Per pound	\$0 42
7 "	" "	56	10 "	" "	46	Put up in any size font required.		
8 "	" "	52	11 "	" "	44			

LAW ITALIC

4-12

28 POINT NO. 42

7A 14a \$4 50

*Watching the Sunrise*  
**NERVOUSLY**

22 POINT NO. 42

8A 20a \$3 60

*Some Wonderful Air-Castles*  
**CONSTRUCTING**

18 POINT NO. 122

10A 28a \$3 30

*To the Voters of the 24th Ward*  
**IMPORTANT NOTICE**

12 POINT NO. 122

14A 42a \$3 00

*This is to certify that a partnership has been  
formed between William Long and Si Perkins*  
**PARTNERSHIP CERTIFICATE**

10 POINT NO. 122

20A 52a \$2 80

*You are hereby commanded to take the body of Ephriam  
Easy, if he be found in Juergen County, and bring him*  
**WARRANT AGAINST MASTER BUILDER**

8 POINT NO. 122      25A 70a \$2 85

**INDENTURE TO LEARN**

*This Indenture witnesseth:  
That Miss Johanna McFlippen,  
daughter of Timothy and Mary*

6 POINT NO. 122      25A 70a \$2 45

**SUMMONS AGAINST A CONSTABLE**

*Whereas, Jonathan Stubbs, a Justice  
of the Peace in and for the County of  
Equal Rights, on the third day of May,  
A. D. 1872, issued an execution to*

## CALIGRAPH

12

12 POINT No. 4

15A 70a \$6 20

Sir: In our last Circular to the trade we called attention to the Low Prices at which the goods were being offered; since that date war rumors have

---

## REMINGTON STANDARD

12

12 POINT

20A 110a \$7 25

110a \$5 25

The Island of Hawaii is the largest of the Hawaiian group and is 300 miles in circumference, is in the form of two great twin peaks--Mauna Loa and Mauna Kea--

---

## YOST TYPEWRITER

15

12 POINT

20A 90a \$6 50

90a \$4 65

Sirs:--Please send, as soon as possible, five fonts of your Yost Typewriter. It has given such general satisfaction that I have resolved to use it on all

SPACES ARE INCLUDED WITH EACH FONT OF TYPEWRITER



---

**TYPEWRITER**

15

12 POINT

20A 108a \$7 50    108 \$4 10

Never in the history of type manufacturing has any face of jobbing type attained a sale and popularity equaling that of this imitation of type-writing machines. The demand for it is co-extensive with the march of civilization, and its use is becoming general where the art of printing is known throughout the

---

**SMITH-PREMIER TYPEWRITER**

11

12 POINT

20A 108a \$7 50    108a \$4 10

This is an exact imitation of the letters (caps and lower case), figures and characters used on the Smith-Premier Machine. Its adaptability will be recognized at once. By its use a circular written on this popular machine may be printed to look precisely like the original. All letters, characters cast on same "set." \$1234 % / #

SPACES ARE INCLUDED WITH EACH FONT OF TYPEWRITER

**TYPEWRITER SERIES**

15

14 POINT NO. 2

15A 75a \$7 50    75a \$5 30

In this new Type-Writer every character is cast on en set, and for spaces the common en quad is used. Job men in general favor this idea, and its popularity is increasing. Its adaptability  
 \$123456 "  $\frac{1}{4}$   $\frac{1}{2}$   $\frac{3}{4}$  # % / - the and

10 POINT NO. 2

18A 85a \$5 00    85a \$3 50

Having had a number of calls for a Type-Writer on 10-Point body, we take pleasure in showing this in answer to the demand. All characters in this font are on en sets, as are also the spaces or justifiers which are put up with the fonts. Very useful in circulars containing a considerable amount of matter. \$1234567

12 POINT EARLE

20A 108a \$7 50    108a \$4 10

Since the original imitation of Type-Writer work was first produced there have been many changes made in the machines, and this Earle style is ~~the~~ a copy of most improved. Very convenient in an amount of matter. \$25  $\frac{1}{2}$  a and % #

SPACES ARE INCLUDED WITH EACH FONT OF TYPEWRITER

CAXTON BLACK

54 POINT

3A 5a \$7 80

Mountains

42 POINT

3A 9a \$5 10

Internal Revenue

30 POINT

4A 12a \$3 80

Renaissance Ornaments

18 POINT

6A 18a \$2 75

Merriment at the Harvest-Home

12 POINT

10A 30a \$2 35

Open Warfare with Enemies of Agriculture

9 POINT

10A 30a \$2 15

Scenes from all Parts of the World (Portrayed

8 POINT

12A 40a \$2 15

Upright Business Method

1234567890

6 POINT

14A 45a \$1 75

Description of the Bipedal Family

1234567890

TUDOR BLACK

---

72 POINT

3A 5a \$12 00

Branch

48 POINT

5A 8a \$8 50

Cremation

40 POINT

4A 12a \$6 00

Sure 8 Aim

36 POINT

4A 12a \$5 50

Louder Brands  
Proclaimed

24 POINT

5A 15a \$4 75

Modern Theorists  
Desirable 4

**TUDOR BLACK**

20 POINT

5A 15a \$3 50

**Destroying Thousands  
Determined**

18 POINT

8A 25a \$3 40

**Baltimores Newest Cohorts  
Adoring Freedom 84**

12 POINT

9A 30a \$2 75

**Colored Antique Volumes Entrancing  
Modern Small Notary**

10 POINT

12A 36a \$2 75

**Modern Enthusiast Engrossing Governors  
Proclamation Securing 46**

8 POINT

15A 50a \$2 75

**Ornithological Productions Clandestinely Displaying  
Majestic Ophthalmic Malformations  
Including Historical Predominating Effects**

6 POINT

15A 50a \$2 25

**Normal School Properties Enhanced Precocious Instruction Abroad  
Supernumerary Education Discounted  
Eligible Pupils Admitted Ostracising New Vaccination**

**PRIORY TEXT No. 2**

---

36 POINT

5A 8a \$6 00

**Generous People**

30 POINT

6A 10a \$5 00

**Columbia Republican**

18 POINT

8A 20a \$4 00

**Previous Sufferings Disputed**

12 POINT

8A 24a \$3 19

**Bright Scholar Quoting Ancient History**

---

**PRIORY TEXT No. 1**

---

14 POINT

8A 24a \$3 64

**United Braintown Classic Societies**

12 POINT

12A 32a \$3 08

**Ynstrums Remarkable Meteorological Display**

10 POINT

16A 40a \$3 42

**Floricultural Enjoyment by Enthusiastic Gardener Boys**

8 POINT

16A 44a \$3 00

**Remarkable Crimes Related by Rescued Mariners from Cannibals**

ANGLO-SAXON No. 20

2

60 POINT

3A 4a \$8 00

Underneath

48 POINT

3A 5a \$5 50

Loves Misery

36 POINT

3A 5a \$4 00

Adolphus Sockser

28 POINT

4A 9a \$3 50

Tough Murder Weekly

22 POINT

4A 12a \$3 00

Advancing Southern Tradesmen

18 POINT

6A 16a \$2 75

Wonders Gained by Devoted Readings

12 POINT

8A 20a \$2 50

Outrageous Treatments of Youthful Benedicts  
Friends and Fellow Citizens Desist

**BOSTON BLACK**

36 POINT

3A 4a \$4 50

Prime 23 Races

28 POINT

4A 6a \$4 50

Tremont 4 Branch

22 POINT

4A 10a \$3 50

Artistic Sign Painters

18 POINT

5A 14a \$3 00

12 POINT

5A 18a \$2 75

Grand Patriot | Modern History

**AUGUSTAN TEXT**

24 POINT

6A 14a \$5 17

Europeans and Americans

18 POINT

8A 16a \$4 49

Theological Books 145 Stationery

12 POINT

8A 24a \$3 34

Winchester Citizens Celebrating Anniversary

10 POINT

10A 40a \$3 02

Lexington Monument Association Trafalgar Square \$263

8 POINT

20A 40a \$3 06

6 POINT

20A 70a \$2 93

Lecture on the Ancient Holy Land  
Eminent Professionals 730

Biographical Sketch of Modern Archer  
2145 Theological Institutions



TITLE BLACK

36 POINT

3A 6a \$6 10

**White House**

24 POINT

4A 8a \$4 45

**Dedicate Building  
Enthusiasm**

18 POINT

5A 10a \$3 40

**National Games Played  
Cricket Matches**

12 POINT

7A 16a \$3 00

**American Investors Triumphant  
Telegraphic Despatches**

10 POINT

8A 20a \$2 85

**Obstructing the Footpath of Dissolution  
Guarantee of Longevity**

8 POINT

8A 20a \$2 70

**Language of the Plumed Birds and Reptiles  
Tropical Melodies Warbled**

6 POINT

10A 28a \$2 50

**Astonishing Revelations of Microscopical Investigation  
Interesting Studies in Natural Science**

1 2 3 4 5 6 7 8 9 0

PARISIAN BLACK No. 120

24 POINT

5A 12a \$5 30

Mistaken Chinamen  
Pursuance

18 POINT

5A 12a \$3 85

Recruit Deserts Comrade  
Deserve 24 Content

12 POINT

6A 16a \$3 40

Presents Disfavored Condition  
36 Honorable Millionaire

10 POINT

8A 24a \$3 25

Notable Elections Bewilder Patriots  
Unexpected Landslide 24

8 POINT

8A 24a \$2 75

Beneath Shade Trees Weary Mortals Rest  
Recuperating Maiden Perambulates

6 POINT

10A 30a \$2 75

Sterile Plains Invite Venturesome Reckless Settler  
345 Pleased Husbandman Returns

YONKERS SERIES

48 POINT

3A 8a \$6 95

East Winds

36 POINT

4A 8a \$4 50

Terrace Garden

30 POINT

5A 10a \$3 85

Cradle of Liberty 6

22 POINT

8A 15a \$3 45

Monday Evening Report

14 POINT

10A 20a \$2 30

United Braintown Classic Society

12 POINT

15A 25a \$2 30

Associations of Photographic Intermeddlers  
Manipulate Amateur Camera

10 POINT

20A 30a \$2 25

Remarkable Meteorological Discovery Announced  
Weather Prognostication Science

8 POINT

25A 40a \$2 10

Floricultural Pleasures Described by Enthusiastic Gardener  
Delicately Formed Leaves and Buds

**Poster Old Style Antique No. 120**

12

30 POINT

25 LB. FONT \$12 50

PRINTING HAS  
Been recognized  
by educated men  
as a subject of all  
importance 23658

24 POINT

25 LB. FONT \$12 50

FIRST INVENTION  
Of printing has always  
been a subject of great  
importance to men of  
education: there is no  
mechanical art, nor are  
there any of the finer

**Poster Old Style Antique No. 120**

18 POINT

25 LB. FONT \$13 00

FIRST INVENTION OF  
Printing has always been a  
subject of great importance  
to men of education; there is  
no mechanical art, nor are  
there any of the fine arts,  
about whose early history  
so many books have 23456

12 POINT

25 LB. FONT \$13 50

THE INVENTION OF PRINTING  
Has always been recognized by men  
of education as a subject of very great  
importance: there is no mechanical  
art, nor are there any fine arts, about  
whose early history so many volumes  
have been written. The subject is as  
mysterious as it is inviting. There is  
an unusual degree of obscurity about  
the origin of the first printed books  
and the lives and works of the early  
printers. There are many records and  
traditions which cannot be reconciled  
of at least three distinct inventions of

**POSTER DE VINNE**

15

36 POINT

25 LB. FONT \$12 50

**COST SALE**  
**For ten days**  
**we are going**  
**to reduce our**

30 POINT

25 LB. FONT \$12 50

**THIS COUNCIL**  
**Will convene on**  
**the 7th of next**  
**month, but will**  
**it pass the tariff**  
**bill reducing the**

**POSTER DE VINNE**

15

24 POINT

25 LB. FONT \$12 50

# ANNUAL FAIR

The Directors take pleasure in stating that the Second Annual Fair of the St. Mary County Agri-

18 POINT

25 LB. FONT \$13 00

# SOCIAL HOP

The members of the Joyful Social Club will give an entertainment and hop at the North Hall, corner Second and Main streets, on Monday evening next. Tickets 25 cents. For sale at book stores and by all members

**POSTER DE VINNE**

12 POINT

25 LB. FONT \$13 50

**EXECUTOR'S SALE**

The undersigned, Executor of the estate of Smith Brown, deceased, will offer for sale at public vendue to the highest bidder for cash, at the east

10 POINT

25 LB. FONT \$16 25

**NOTICE TO SUBURBANITES**

Commencing on Monday, the 24th inst., trains for Sitka and Yeddo will leave the depot at 9:30 A. M. and 3:15 P. M. Passengers on the morning trains have privilege of stopping off at Sitka until arrival of evening train. The evening

8 POINT

25 LB. FONT \$20 00

**PUBLIC SPEAKING IN THE COURT HOUSE**

Hon. E. Pluribus Unum will address his fellow-citizens on the political issues of the day at the Court House in this city at 7:23 o'clock this evening. Everybody invited. Frauds exposed and a powerful search light turned on the dark ways of the opposition party.

6 POINT

25 LB. FONT \$25 00

**EXTENSIVE SALE OF WATCHES AND JEWELRY**

The undersigned finds it necessary to reduce his large and varied stock of Watches, Clocks, Jewelry, Gold and Silver Plated Ware, Fine Cutlery, Stationery, Fancy Goods, Etc., and will offer any article in his store at 25 per cent. off the regular price for thirty days. This offer includes Diamonds, and in the stock may be found some of the finest in the market. Watches of American, Swiss, English, German and French manufacture, in gold, silver, nickel



POSTER DE VINNE CONDENSED

15

42 POINT

25 LB. FONT \$12 50

**SERVICES**  
**For men only**  
**at 4 p. m., on**  
**Monday after**

36 POINT

25 LB. FONT \$12 50

**POLITICAL**  
**Meetings every**  
**night until elec-**  
**tion, concluding**

FONTS DO NOT CONTAIN SPACES AND QUADS

**POSTER DE VINNE CONDENSED**

—15—

30 POINT

25 LB. FONT \$12 50

**GRAND RAFFLE**  
**A Gold Watch, one**  
**Diamond Ring, four**

24 POINT

25 LB. FONT \$12 50

**HORSE EXHIBITION**  
**The Southwestern Horse**  
**Breeders' Association in=**  
**vite the co=operation of**

18 POINT

25 LB. FONT \$13 00

**HARVEST EXCURSIONS**  
**The Fast Flying Railway Com=**  
**pany will sell excursion tickets**  
**over their lines, good for thirty**  
**days, for one and one=third fare**

**POSTER DE VINNE CONDENSED**

—15—

14 POINT

25 LB. FONT \$13 00

**STOCKHOLDERS' MEETING**

Notice is hereby given that the annual meeting of the stockholders and directors of the Dismal Swamp and Sleepy Hollow Railway will be held on the

12 POINT

25 LB. FONT \$13 50

**DISSOLUTION OF COPARTNERSHIP**

The firm of Bluster & Wind, composed of B. Bluster and H. Wind, is this day dissolved by mutual consent, H. Wind retiring. Mr. B. Bluster will continue the business, collect all

10 POINT

25 LB. FONT \$16 25

**DESIRABLE BUILDING LOTS AT AUCTION**

On Wednesday, 23d inst., those twelve choice building lots on Singapore avenue, between Queensland and Edinburgh streets, will be sold at public auction. Each lot has a frontage of 25 feet by a depth of 175.6 to a 20-foot alley. Street improvements made, and no taxes for two years. Terms of sale: One-third cash, balance in one and two

8 POINT

25 LB. FONT \$20 00

**MASS MEETING OF PROPERTY OWNERS**

A meeting of the freeholders of Terradelfuego County will be held at Kickers' Hall on Saturday evening, June 10, at 7 o'clock, to protest against the action of the majority of the Committee on Public Improvements of the Township Board of Trustees in recommending the granting of privilege to the Universe Aerial Navigation Company to sail or transport their vessels over the

POSTER LATIN ANTIQUE No. 120

36 POINT

25 LB. FONT \$12 50

PRINTERS  
once upon a  
time carried  
swords 485

30 POINT

25 LB. FONT \$12 50

RECOGNIZED  
The history of  
Printing is the  
most interest-  
ing subject for  
the youth 362

FONTS DO NOT CONTAIN SPACES AND QUADS

POSTER LATIN ANTIQUE No. 120

24 POINT

25 LB. FONT \$12 50

INVENTION  
Printing has been  
recognized as the  
most important 4

18 POINT

25 LB. FONT \$13 00

EARLY INVENTION  
Printing has always had  
recognition by educated  
people on account of its  
mysterious origin. The  
lives and works of these

12 POINT

25 LB. FONT \$13 50

INVENTION OF PRINTING  
Has always been recognized by  
educated people as a subject of  
great importance. There is no  
mechanical art, nor any of the  
fine arts, about whose history so  
many books have been written

POSTER ANTIQUE No. 125

---

48 POINT

25 LB. FONT \$12 50

THE Art  
Provides

36 POINT

25 LB. FONT \$12 50

THE art of  
Printing is  
recognized

30 POINT

25 LB. FONT \$12 50

THE ART OF  
Printing to the  
educated has

POSTER ANTIQUE No. 125

12

24 POINT

25 LB. FONT \$12 50

THE INVENTION  
Of Printing always  
has been recognized

18 POINT

25 LB. FONT \$13 00

THE INVENTION OF  
Printing has always been  
recognized by educated  
men as a subject of vast

12 POINT

25 LB. FONT \$13 50

THE INVENTION OF PRINTING  
Has always been recognized by men  
of education as a subject of great  
importance; there is no mechanical  
art, nor are there any of the fine arts

10 POINT

25 LB. FONT \$16 25

THE INVENTION OF PRINTING HAS  
Always been recognized by educated men  
as a subject of vast importance; there is no  
mechanical art nor are there any of the fine  
arts about whose history so many books have  
been written. There is an unusual degree  
of obscurity about the origin of the earliest

**POSTER IONIC**

12

★42 POINT NO. 150

25 LB. FONT \$12 50

**EARLIER**  
Printing by  
men whose  
genius now

36 POINT NO. 122

25 LB. FONT \$12 50

**SELECTING**  
Durable Type  
Faces suitable  
for Posters or



POSTER IONIC No. 122

12

30 POINT

25 LB. FONT \$12 50

**PRINTING HAS**  
Been recognized  
by educated men

24 POINT

25 LB. FONT \$12 50

**PRINTING MAKES**  
your trade what you  
make your printing

18 POINT

25 LB. FONT \$13 00

**THE INVENTION OF**  
Printing has always been  
recognized by educated  
men as a subject of great

12 POINT

25 LB. FONT \$13 50

**THE INVENTION OF PRINTING**  
Has been recognized by educated  
men as a very important subject  
in the mechanical arts. There is

POSTER LIGHTFACE No. 158

24 POINT

25 LB. FONT \$12 50

HE THAT WILL  
often put eternity  
and the world in  
front of him, and

20 POINT

25 LB. FONT \$13 00

TREES AS WE SEE  
them, love them and  
adore them in forests,  
where they are alive,  
holding their verdant

18 POINT

25 LB. FONT \$13 00

ANNOUNCEMENT  
I, G. Placeseker, hereby  
announce myself a candi-  
date for the office of Town  
Inspector, subject to the

**POSTER LIGHTFACE No. 158**

15

12 POINT

25 LB. FONT \$13 50

OUR LIFE IS APPRENTICESHIP  
to the truth that around every circle  
another can be drawn; that there is  
no end in nature, but every end is a  
beginning; that there is always one  
more morn risen on mid-noon, and  
under every deep a lower deep opens.  
Some learn the lesson well and other

10 POINT

25 LB. FONT \$16 25

THE GREAT THING IN THIS WORLD  
is not so much where we stand as what  
direction we are moving. To reach the  
port of heaven we must sail sometimes  
with the wind and sometimes against  
it—but we must sail and not drift nor  
lie at anchor. We must ever keep our  
sails set, a full head of steam on and our  
rudder steering straight toward harbor

8 POINT

25 LB. FONT \$20 00

NATURE IS FOND OF WHAT ARE CALLED  
gift enterprises. This little book of life which  
she has given into the hands of its possessors  
is commonly one of the old story books bound  
over again. Only once in a great while there  
is a stately poem in it, or its leaves are made  
grand and beautiful by being illuminated with  
the glories of art. Such gifts however are not  
confined to any particular walk of life, but on  
the contrary the surprises are met with quite

FONTS DO NOT CONTAIN SPACES AND QUADS.

6 POINT GERMAN NO 121



Der menschliche Fleiß hat die Erde angebaut, und den widerstrebenden Boden durch sein Beharren und seine Geschicklichkeit überwunden. Dort hat er dem Meere Land abgewonnen, hier dem dürrn Lande Ströme gegeben. Zonen und Jahreszeiten hat der Mensch durcheinander gemengt, und die weichlichen Gewächse des Orients in seinem rauheren Himmel abgehärtet. Wie er Europa nach Westindien und dem Südmeere trug, hat er Asien in Europa auferstehen lassen. Ein heiterer Himmel lacht jetzt über Germaniens Wäldern, welche die starke Menschenhand zerriß und dem Sonnenstrahl aufthat und in den Wellen des Rheins spiegeln sich Asiens Neben. An seinen Ufern erheben sich schöne volkreiche Städte, die Genuß und Arbeit in munterem Leben durchschwärmen. Hier finden wir den Menschen in seines Gewerbes friedlichem Besitz sicher unter einer Million, ihn, dem sonst ein einziger Nachbar den Schlummer raubte. Die Gleichheit, die er durch seinen Eintritt in die Gesellschaft verlor, hat er wieder

ABCDEFGHIJKLMNOPQRSTUVWXYZ

\$1234567890

abcdefghijklmnopqrstuvwxyz

7 POINT GERMAN NO. 121



Der menschliche Fleiß hat die Erde angebaut, und den widerstrebenden Boden durch sein Beharren und seine Geschicklichkeit überwunden. Dort hat er dem Meere Land abgewonnen, hier aber dem dürrn Lande Ströme gegeben. Zonen und Jahreszeiten hat der Mensch durcheinander gemengt und die weichlichen Gewächse des Orients zu seinem viel rauheren Himmel abgehärtet. Wie er Europa nach Westindien und dem Südmeere trug, so hat er Asien in Europa auferstehen lassen. Ein heiterer Himmel lacht jetzt über Germaniens Wäldern, welche die starke Menschenhand zerriß und so dem Sonnenstrahl aufthat, und in den Wellen des Rheins spiegeln sich Asiens Neben. An seinen Ufern erheben sich volkreiche Städte, die Genuß und Arbeit in munterem Leben durchschwärmen. Hier finden wir den

ABCDEFGHIJKLMNOPQRSTUVWXYZ

\$1234567890

abcdefghijklmnopqrstuvwxyz

8 POINT GERMAN NO. 121



Der menschliche Fleiß hat die Erde angebaut, und auch den widerstrebenden Boden durch sein Beharren sowie auch durch seine Geschicklichkeit überwunden. Dort hat er dem Meere Land abgewonnen, hier dem dürrn Lande Ströme gegeben. Zonen und Jahreszeiten hat der Mensch durcheinander gemengt, und die weichlichen Gewächse des Orients zu seinem rauheren Himmel abgehärtet. Wie er Europa nach Westindien und dem Südmeere trug, hat er Asien in Europa auferstehen lassen. Ein heiterer Himmel lacht jetzt über Germaniens Wäldern, welche die starke Menschenhand zerriß und dem Sonnenstrahl aufthat und in den

ABCDEFGHIJKLMNOPQRSTUVWXYZ

\$1234567890

abcdefghijklmnopqrstuvwxyz

9 POINT GERMAN No. 121



Der menschliche Fleiß hat die Erde angebaut, und so den widerstrebenden Boden durch sein Beharren sowohl als auch durch seine Geschicklichkeit überwunden. So hat er dort dem Meere Land abgewonnen, während er hier dem dürren Lande Ströme gegeben. Zonen und Jahreszeiten hat der Mensch durcheinander gemengt, sowie die weichlichen Gewächse des Orients zu seinem rauheren Himmel abgehärtet. Wie er Europa nach Westindien und dem Südmeere trug, so hat er

A B C D E F G H I J K L M N O P Q R S T U V W X Y Z

\$1234567890

abcdefghijklmnopqrstuvwxyz

10 POINT GERMAN No. 121



Der menschliche Fleiß hat die Erde angebaut und den widerstrebenden Boden auch durch sein Beharren und seine Geschicklichkeit überwunden. Dort hat er von dem Meere Land genommen, hier dem dürren Lande Ströme gegeben. Zonen und Jahreszeiten hat der Mensch durcheinander gemengt und die weichlichsten Gewächse des Orients zu seinem rauhen Himmel abgehärtet. Wie er Europa nach

A B C D E F G H I J K L M N O P Q R S T U V W X Y Z

\$1234567890

abcdefghijklmnopqrstuvwxyz

11 POINT GERMAN No. 121



Der menschliche Fleiß hat die Erde angebaut und den widerstrebenden Boden durch sein Beharren und seine Geschicklichkeit überwunden. Dort hat er dem Meere Land abgewonnen, hier dem bedürftigen Lande Ströme gegeben. Zonen und Jahreszeiten hat der Mensch durcheinander gemengt, und die weichlichsten

A B C D E F G H I J K L M N O P Q R S T U V W X Y Z

\$1234567890

abcdefghijklmnopqrstuvwxyz

12 POINT GERMAN NO. 121

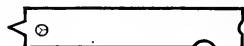

Der menschliche Fleiß hat die Erde angebaut und somit den widerstrebenden Boden durch sein Beharren und seine Geschicklichkeit überwunden. Dort hat er dem Meere Land abgewonnen, hier dem bedürftigen Lande Ströme gegeben. Zonen und Jahreszeiten hat der Mensch durcheinander gemengt, und die allerweichlichsten Gewächse des Orients zu seinem rauheren Himmel abgehärtet wie er Europa nach Westindien und dem Meere trug und Asien in Europa auferstehen ließ, doch

A B C D E F G H I J K L M N O P Q R S T U V W X Y Z

\$1234567890

abcdefghijklmnopqrstuvwxyz

14 POINT GERMAN NO. 121

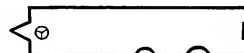

Der menschliche Fleiß hat unbedingt die Erde angebaut und widerstrebenden Boden durch sein Beharren sowie auch durch seine Geschicklichkeit überwunden, wie er dort dem Meere Land abgewonnen und hier dem bedürftigen Lande Ströme gegeben hat. Zonen und Jahreszeiten hat der Mensch durcheinander gemengt und die weichen Gewächse des Orients

A B C D E F G H I J K L M N O P Q R S T U

\$1234567890

abcdefghijklmnopqrstuvwxyz

## POSTER GERMAN No. 121

12

18 POINT

20A 100a \$12 48

Menschlicher Fleiß hat die Erde angebaut und den widerstrebenden Boden durch sein Beharren und seine Geschicklichkeit überwunden. Dort hat er dem Meere viel Land

24 POINT

14A 40a \$12 00

Der menschliche Fleiß hat die Erde angebaut sowie den Boden durch Geschicklichkeit fruchtbar gemacht, indem er

30 POINT

8A 60a \$12 00

Menschlicher Fleiß hat die Erde angebaut und so den widerstrebenden Boden durch sein stetes

6 POINT GERMAN No. 153

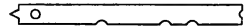

In der Regel soll man beim Papier die Sparbarkeit nicht zu weit treiben; sie ist nur zu entschuldigen bei Schulbüchern, Volksausgaben und dergleichen, wo oft Cents den Ausschlag in der Calculation eines Exemplars geben. Bei einem Buch, dessen Verkaufspreis aber ein angemessener sein kann, macht das bessere oder weniger gute Papier nur einen ganz kleinen Unterschied in den Herstellungskosten. Für einen guten Druck ist ein gutes Papier unumgänglich nothwendig. Es muß gleichmäßig stark gearbeitet sein, denn sonst würde beim Drucken der dicke Bogen übermäßig stark und der dünne nur schwach gefärbt. Der Stoff muß ein guter baumwollener oder leinener, kräftig, fest und doch mild sein, damit er die Farbe leicht annimmt; die Beimischung von erdigen Bestandtheilen ist immer nachtheilig. Da das Papier nach der Feinheit des Stoffes und der Schwere verkauft wird, so werden leider von vielen Papier-Fabrikanten geringwerthige Lumpen genommen, die sie nach einer gewaltsamen chemischen Bleiche nicht genügend reinigen und durch erdige Zusätze schwer machen. Abgesehen von dem Schaden für die Buchdruckerei, an ruinirten Schriften, sieht der Druck grau aus. Ein anderes, in neuerer Zeit vielfach benutztes Verfahren ist die Papierstereotypie. Statt die Schrift mit Gypsbrei anzugießen, bedeckt man sie mit einer Anzahl Blättern von Seidenpapier, die einzeln mit einer bindenden Masse bestrichen werden. Mit einer Bürste wird auf diese feuchte Papierbede so lange geklopft, bis die Schrift vertieft vollständig in dieselbe abgedruckt ist. Unter einer starken Pressung bei mäßiger Hitze wird sie langsam getrocknet,

A B C D E F G H I J K L M N O P Q R S T U V W X Y Z

\$1234567890

abcdefghijklmnopqrstuvwxyz

8 POINT GERMAN No. 153



In der Regel soll man beim Papier die Sparbarkeit nicht zu weit treiben; sie ist nur zu entschuldigen bei Schulbüchern, Volksausgaben und dergleichen, wo oft Cents den Ausschlag in der Calculation eines Exemplars geben. Bei einem Buche, dessen Verkaufspreis aber ein angemessener sein kann, macht das bessere oder weniger gute Papier einen ganz kleinen Unterschied in den Herstellungskosten. Für einen guten Druck ist ein gutes Papier unumgänglich nothwendig. Es muß gleichmäßig stark gearbeitet sein, denn sonst würde beim Drucken der dicke Bogen übermäßig stark und der dünne nur schwach gefärbt. Der Stoff muß ein guter baumwollener oder leinener, kräftig, fest und doch mild sein, damit er die Farbe leicht annimmt; die Beimischung von erdigen Bestandtheilen ist immer nachtheilig. Da das Papier nach der Feinheit des Stoffes und der Schwere verkauft wird, so werden leider von vielen Papier-Fabrikanten geringwerthige Lumpen genommen, die sie nach einer gewaltsamen chemischen Bleiche nicht genügend reinigen und durch erdige Zusätze schwerer machen. Abgesehen von dem Schaden für die Buchdruckerei, an ruinirten

A B C D E F G H I J K L M N O P Q R S T U V W X Y Z

\$1234567890

abcdefghijklmnopqrstuvwxyz



10 POINT GERMAN NO. 153



In der Regel soll man beim Papier die Sparsamkeit nicht zu weit treiben; sie ist nur zu entschuldigen bei Schulbüchern, Volksausgaben und dergleichen, wo oft Cents den Ausschlag in der Calculation eines Exemplars geben. Bei einem Buch, dessen Verkaufspreis aber ein angemessener sein kann, macht das bessere oder weniger gute Papier nur einen kleinen Unterschied in den Herstellungskosten. Für einen guten Druck ist ein gutes Papier unumgänglich nothwendig. Es muß gleichmäßig stark gearbeitet sein, denn sonst würde beim Drucken der dicke Bogen stark und der dünne nur schwach gefärbt. Der Stoff muß ein guter baumwollener oder leinener, kräftig, fest und doch mild sein

A B C D E F G H I J K L M N O P Q R S T U V W X Y Z

\$1234567890

abcdefghijklmnopqrstuvwxyz

11 POINT GERMAN NO. 153

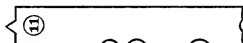

In der Regel soll man beim Papier die Sparsamkeit nicht zu weit treiben; sie ist nur zu entschuldigen bei Schulbüchern, Volksausgaben und dergleichen, wo oft Cents den Ausschlag in der Calculation eines Exemplars geben. Bei einem Buch, dessen Verkaufspreis aber ein angemessener sein kann, macht das bessere oder weniger gute Papier nur einen ganz kleinen Unterschied in den Herstellungskosten. Für einen guten Druck ist ein gutes Papier unumgänglich nothwendig. Es muß gleichmäßig stark gearbeitet sein, denn sonst würde beim Drucken der dicke Bogen übermäßig stark und der dünne nur schwach gefärbt. Der Stoff muß ein guter leinener

A B C D E F G H I J K L M N O P Q R S T U V W X Y Z

\$1234567890

abcdefghijklmnopqrstuvwxyz

6 POINT GERMAN NO. 155



Zu einem guten Buche genügt es nicht allein, daß der Buchdrucker einen sorgfältigen Satz liefert, neue Schrift, eine gute Maschine und feine Farbe daran verwendet; alle seine Arbeit ist umsonst, wenn nicht der Besteller des Buches auch für ein gutes Papier Sorge trägt. Von Seiten der Besteller werden oft große Ansprüche an die Druckereien hinsichtlich der zu verwendenden Schriften gestellt und dann ein Papier geliefert, so voll von Knoten oder gar von Sand, daß die feine Bildfläche einer neuen Schrift nach wenigen Abzügen ruinirt ist und nach einigen Stunden die Lager und Zahnräder der Maschinen und die Farbwalzen voll von dem schmutzigen Abgang des Papiers sind. Dit wird auch ein so schwaches und dünnes Papier genommen, daß der Druck durchschim-

ABCDEFGHIJKLMNOPQRSTUVWXYZ

\$1234567890

abcdefghijklmnopqrstuvwxyz

8 POINT GERMAN NO. 155



Zu einem guten Buche genügt es nicht allein, daß der Buchdrucker einen sorgfältigen Satz liefert, neue Schrift, eine gute Maschine und feine Farbe daran verwendet; alle seine Arbeit ist umsonst, wenn nicht der Besteller des Buches auch für ein gutes Papier Sorge trägt. Von Seiten der Besteller werden oft große Ansprüche an die Druckereien hinsichtlich der zu verwendenden Schriften gestellt und dann ein Papier geliefert, so voll von Knoten oder gar von Sand, daß die feine

ABCDEFGHIJKLMNOPQRSTUVWXYZ

\$1234567890

abcdefghijklmnopqrstuvwxyz

9 POINT GERMAN NO. 155

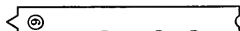

Zu einem guten Buche genügt es nicht allein, daß der Buchdrucker einen sorgfältigen Satz liefert, neue Schrift, eine gute Maschine und feine Farbe daran verwendet; alle seine Arbeit ist umsonst, wenn nicht der Besteller des Buches auch für ein gutes Papier Sorge trägt. Von Seiten der Besteller werden oft große Ansprüche an die Druckereien hinsichtlich der zu verwendenden Schriften

ABCDEFGHIJKLMNOPQRSTUVWXYZ

\$1234567890

abcdefghijklmnopqrstuvwxyz

10 POINT GERMAN No. 155

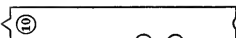

In der Regel soll man beim Papier die Sparsamkeit nicht zu weit treiben; sie ist zu entschuldigen bei Schulbüchern, Volksausgaben und dergleichen, wo oft Cents den Ausschlag in der Calculation eines Exemplars geben. Bei einem Buche, dessen Verkaufspreis aber ein angemessener sein kann, macht das bessere oder weniger gute Papier nur einen ganz kleinen Unterschied in den Herstellungskosten. Für einen guten Druck ist ein gutes Papier unumgänglich nothwendig. Es muß gleichmäßig stark gearbeitet sein, denn sonst würde ein Bogen stark und ein anderer nur schwach gefärbt werden.

A B C D E F G H I J K L M N O P Q R S T U V W X Y Z

\$1234567890

abcdefghijklmnopqrstuvwxyz

12 POINT GERMAN No. 155

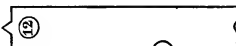

In der Regel soll man beim Papier die Sparsamkeit nicht zu weit treiben; sie ist nur zu entschuldigen bei Schulbüchern, Volksausgaben und dergleichen, wo oft ein Cent den Ausschlag in der Calculation eines Exemplars giebt. Bei einem Buch, dessen Verkaufspreis ein angemessener sein kann, macht das bessere oder weniger gute Papier nur einen kleinen Unterschied in den Herstellungskosten. Für einen guten Druck ist ein gutes Papier nöthig

A B C D E F G H I J K L M N O P Q R S T U V W X Y Z

\$1234567890

abcdefghijklmnopqrstuvwxyz

German Title Condensed No. 150

72 POINT

3A 8a \$12 00

Zeitung 12

60 POINT

4A 10a \$13 00

Opernlieder

42 POINT

4A 10a \$10 00

Traute Heimath

36 POINT

5A 15a \$7 75

Moderne Kunst 96

30 POINT

8A 20a \$6 60

Sa! nehmt hin die Welt!

20 POINT

8A 24a \$5 75

Europäische Alterthümlichkeiten

German Title Condensed No. 150

18 POINT

9A 30a \$4 50

Correspondenten eines täglichen Blattes  
Telegraphische Nachrichten \$30

14 POINT

12A 40a \$4 00

Proben neuer Buch- und Zeitungs-Schriften  
Elegante typographische Fachblätter 25

12 POINT

16A 50a \$4 50

Monatliches Journal für die höhere Buchdruckerkunst  
Verbreitet technischen Unterricht in Mexico 64

11 POINT

16A 50a \$3 75

Romantische Erzählungen eines alten deutschen Dichters  
Schriftsteller vergangener Jahrhunderte 18

10 POINT

16A 50a \$3 50

Wie herrlich glänzt die Sonne an diesem schönen Morgen  
Beleuchtet zaubernd die erfrischte Natur 20

9 POINT

16A 50a \$3 15

Abend-Unterhaltungen und Tanzkränzchen für fröhliche Menschen  
Vergnügungen veranstaltet im Orpheus-Garten 36

8 POINT

16A 50a \$3 00

Zwölfte große Festlichkeit der deutsch-amerikanischen Sängerbunde  
Program für das Concert der vereinigten Chöre 75

GERMAN TITLE No. 122

—12—

42 POINT

3A 6a \$5 35

Meisterwerkes

36 POINT

3A 6a \$3 95

Pistole 4 Weide

30 POINT

4A 10a \$4 80

Einiges Aufsehen  
Frauenliebe 6

24 POINT

7A 20a \$4 75

Complicirte Geschichten  
38 Münchhausen

18 POINT

7A 20a \$3 50

Regierung sendet Truppen  
Unerhört 25 Aufstand

GERMAN TITLE No. 122

—12—

14 POINT

8A 25a \$3 25

**Reisebücher Hamburger Touristen  
Unterhaltender Familienreis**

12 POINT

9A 30a \$3 10

**Menagerie des berühmten Hagenbeck  
Erstaunende 24 Zuschauerin**

11 POINT

9A 30a \$2 60

**Bulverisirter unverfälschter Rübenzucker  
63 Mancherlei Abshweifung**

10 POINT

12A 40a \$3 00

**Landwirthschaftliche Auseinandersetzung  
Theatralische 38 Vorstellung**

9 POINT

15A 50a \$3 95

**Denkungsart philanthropischer Schriftsteller  
Hochgepriesener Schnupftabak 42**

8 POINT

15A 50a \$3 15

**Schwäbischer Verein für undankbare Waschweiber  
684 Nichtswürdige Undankbarkeit**

7 POINT

15A 50a \$3 10

**Unterhaltender Greis belebt hochangesehene Militärleute  
Beängstigende zunehmende Unzufriedenheit 25**

6 POINT

15A 50a \$2 85

**Konversationslexikon der verschiedenen unveränderten Sprachen  
1234 Verleumdete unschuldige Gelehrten**

GERMAN FULL FACE.

15

30 POINT

6A 15a \$8 00

**Kommt die Nacht**

24 POINT

6A 15a \$6 00

**Der Hirsch zu Dickicht**

18 POINT

7A 20a \$4 50

**Den Jüngling reißt es fort**

12 POINT

7A 20a \$3 00

**Ein sanfter Wind vom blauen Himmel**

11 POINT

9A 30a \$3 00

**Zu Mantua in Banden der treue Hofer war**

10 POINT

12A 40a \$3 50

**Die Kunst ist lang, das Leben kurz, die Gelegenheit  
flüchtig, und das Urtheil schwierig**

9 POINT

16A 50a \$3 85

**Morgenroth, leuchtest mir zum frühen Tod; bald wird  
mein Leben lassen, ich und mancher Kamerad 68**

8 POINT

16A 50a \$3 50

**Kaum gedacht, wird der Luft ein End' gemacht; gestern  
noch auf stolzen Rossen, heute durch**

7 POINT

16A 50a \$3 25

**In diesen heil'gen Hallen kennt man die Rache nicht, und ist ein  
Pflicht; dann wandert er an Freundes Hand in's 21**

6 POINT

16A 50a \$3 00

**Jahr' mich hinüber, schöner Schiffer, nach dem Rialto fahre mich  
Sieh', dieses Halsband nimm zum**



TEUTONIC No. 150

36 POINT

5A 12a \$6 75

Mond und Sterne

30 POINT

6A 15a \$7 35

Bauer Franz Suppe

18 POINT

8A 24a \$4 75

Im ganzen Dorfe geht's Gericht

12 POINT

9A 30a \$3 00

So gewiß wie der Schatten dem Lichte folgt

Condensed German Black No. 150

30 POINT

4A 10a \$3 50

Die Thaten für Andenken

24 POINT

4A 10a \$2 50

Wer niemals einen Rausch gehabt

18 POINT

8A 20a \$3 50

Wir besitzen von Natur viele Tugenden

12 POINT

16A 50a \$4 50

Das schöne Morgenroth stieg auf, welches die blendenden

SCHWABACHER SERIES

48 POINT

3A 8a \$6 95

Fälschungen

36 POINT

4A 8a \$4 50

Zwölf 38 Uhren

30 POINT

5A 10a \$3 85

Schwere 9 Brücken

22 POINT

5A 15a \$3 15

Bergwerk 72 Maschinen

14 POINT

9A 30a \$3 20

französische Bibliothek Handlungen

12 POINT

9A 30a \$2 35

Thaten und Sagen 49 des alten Hauptmannes

10 POINT

12A 40a \$2 20

Rückzug der verprügelten Engländer von Venezuela

8 POINT

15A 50a \$2 85

Wunderschöne Luftfahrt zu dem feuerspritzenden Popocatepetl

6 POINT

15A 50a \$1 95

Einfluß der Deutschen auf die Gestaltung einer separaten Reform-Partei 14

SCHWABACHER No. 2

15

48 POINT

3A 8a \$11 40

**Journal 8**

36 POINT

3A 8a \$7 00

**Ruhe gesucht**

30 POINT

4A 10a \$6 00

**Redensarten 95**

20 POINT

5A 15a \$5 00

**Bildung der Menschen**

16 POINT

6A 18a \$4 00

**Erzählungen im Tagebuch**

14 POINT

7A 20a \$3 75

**fünfter Verein der Buchdrucker**

12 POINT

8A 24a \$3 50

**Zwölf wöchentliche Unterhaltungen**

10 POINT

10A 30a \$3 25

**Eisenbahn von Madrid nach Constantinopel**

8 POINT

14A 42a \$3 00

**Verweilet sich in der Schenke im Kreise seiner Freunde**

IHLENBURG SERIES

60 POINT

3A 5a \$9 65

**Dichturfürst**

48 POINT

3A 8a \$7 35

**Victor Scheffel**

36 POINT

4A 10a \$5 40

**Eckehart Herzogin**

24 POINT

5A 16a \$3 80

**Trompeter von Säckingen**

18 POINT

8A 25a \$3 55

**Heldengestalten deutscher Geschichte**

12 POINT

15A 45a \$3 25

**Hohentwiel am Neckar  
Druidenfelsen**

10 POINT

16A 50a \$3 00

**Klosterjäger und Waldfrau  
Gefährliche Flucht**

8 POINT

18A 52a \$2 70

**Mittelalterliche Brautwerbung  
Alt-Heidelberg, du feine**

1234567890

6 POINT

20A 60a \$2 40

**Behüt dich Gott, es wäre schön gewesen  
Jedoch es hat nicht sollen sein**

1234567890

COMPOSITE No. 150

30 POINT

6A 15a \$6 75

Preiset die Reben 45

24 POINT

8A 20a \$5 75

Die Thaten und Gedanken  
Wie glänzt die Sonne

18 POINT

10A 25a \$4 25

Wohin gehen die Kinder der Welt  
Vierzig Jahre seiner Kultur?

14 POINT

10A 30a \$3 50

Bei ihm geht die Redlichkeit über Alles  
Sonnenlicht und Morgenröthe 79

12 POINT

16A 50a \$4 50

Des Meeres Gewässer werden durch vier Ursachen  
in Bewegung gesetzt; die Erste von den \$23

GERMANIA No. 150

36 POINT

3A 7a \$6 00

Anzeigen 25

30 POINT

4A 10a \$6 00

Einjamkeit der

24 POINT

5A 15a \$5 75

Dichter und Bauer

18 POINT

7A 20a \$5 10

Nicht jeder Tag kann  
Wölkchen 325

16 POINT

8A 24a \$4 50

Brachte tägliche Nachrichten  
Europäischer Frieden 34

12 POINT

10A 30a \$3 90

Neue Ansiedler im fernen Westen  
Verlassen ältere Länder

10 POINT

13A 40a \$3 70

Ein niedliches Mädchen, ein junges Blut  
War einem Soldaten gut

9 POINT

14A 42a \$3 25

D'rum frisch, Kameraden, den Klappen gezäumt  
Frisch auf, eh' der Geist noch verduftet 46

HEINTZEMANN SERIES

30 POINT

6A 20a \$7 10

Loblieder am Altare

24 POINT

8A 25a \$5 80

Herzogtum 86 Provinzen

18 POINT

10A 30a \$4 95

Deutliche Schrift 2 schöner Schnitt

14 POINT

12A 40a \$4 80

Beobachtungen am Observatorium 40  
Entdeckung neuer Kometen

12 POINT

12A 40a \$3 35

Zeitungen der Pariser Ausstellung  
Seksmaschinen und 28 riesige Rotationspressen

10 POINT

12A 40a \$2 85

Die hohe Stufe, welche die Buchdruckerkunst unter den Erfindungen des menschlichen Geistes einnimmt, hat die Ehre 23

8 POINT

15A 50a \$2 60

Die Geburtsstadt derselben zu sein, zum Gegenstande eines lebhaften und nicht beendeten Streites gemacht, seit Strassburg, und besonders aber seit Harlem es sich angelegen 67

9 POINT

12A 50a \$2 60

Die hohe Stufe, welche die Buchdruckerkunst unter den Erfindungen des menschlichen Geistes einnimmt, hat die Ehre, die Geburts-

6 POINT

15A 50a \$2 15

Stätte derselben zu sein, zum Gegenstande eines lebhaften und noch nicht beendigten Streites gemacht, seit Strassburg, besonders aber seit Harlem es sich angelegen sein ließ, die Stadt Mainz aus ihrem früher unbestrittenen ausschließlichen Besitze, der von Harlem sogar 482

**Ornamental Cast Initials**

SERIES NO. 1148 B 11

Per Set \$3 50 Single Letter 30 cts. For Two Colors \$7 00 Each 60 cts.

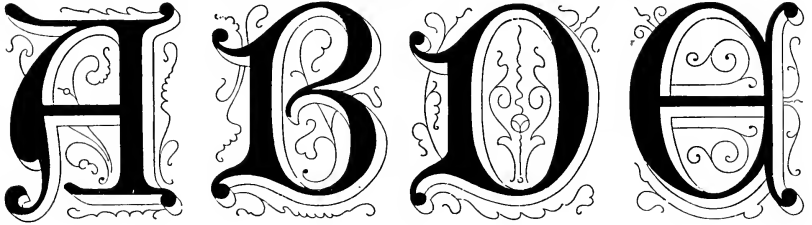

SERIES NO. 1147 B 11

Per Set \$2 25 Single Letter 25 cts.  
For Two Colors \$4 50 Each 50 cts.

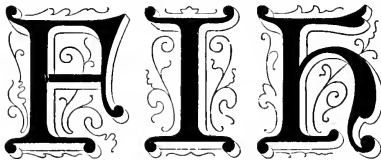

SERIES NO. 1146 B 11

Per Set \$1 75 Single Letter 20 cts.  
For Two Colors \$3 50 Each 40 cts.



SERIES NO. 443 B 4

Per Set \$4 00 Single Letter 40 cts.

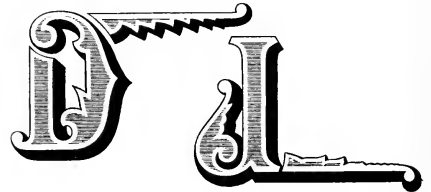

SERIES NO. 440 B 4

Per Set with Pendants \$5 00  
Single Letter with Pendants  
40 cts.

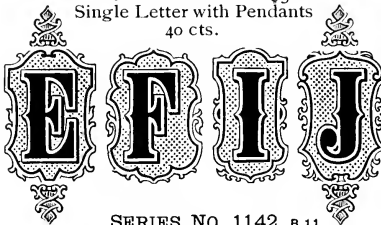

SERIES NO. 1142 B 11

Per Set \$2 00



SERIES NO. 1143 B 11

Per Set \$3 50

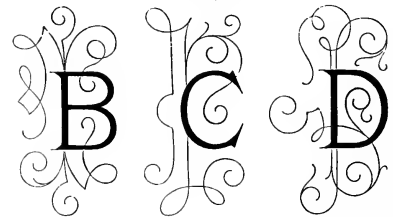

SERIES NO. 321

ORNAMENTED

Per Set \$7 50 Each 50 cts.

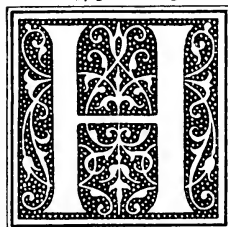

SERIES NO. 321 B 3

PLAIN

Per Set \$6 00 Each 50 cts.

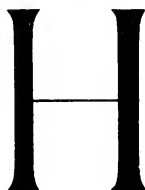

SERIES NO. 320

ORNAMENTED

Per Set \$5 00  
Each 35 cts.



SERIES NO. 320

PLAIN

Per Set \$3 50  
Each 35 cts.



Series No. 320 and No. 321 are designed to work together in colors.



**Ornamental Cast Initials**

72 POINT ART INITIALS

B 15

Per Set with Ornaments \$4 00

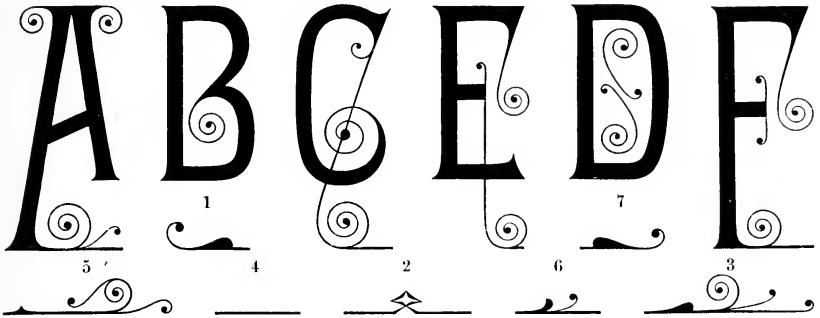

48 POINT ART INITIALS

B 15

Per Set with Ornaments \$3 00

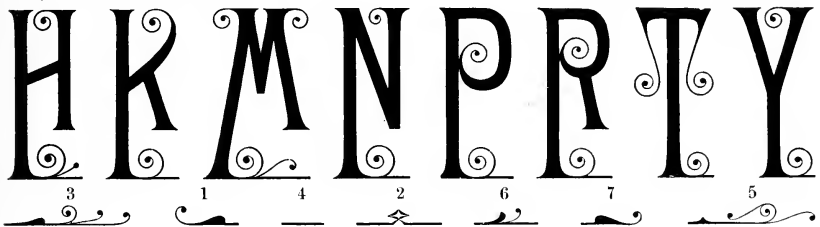

SERIES NO. 1133

B 11

Per Set \$3 50 Single Letter 40 cts.



SERIES NO. 1132

B 11

Per Set \$3 50 Single Letter 40 cts.



48 POINT MORTISED NO. 2

B 4

3 A \$6 00

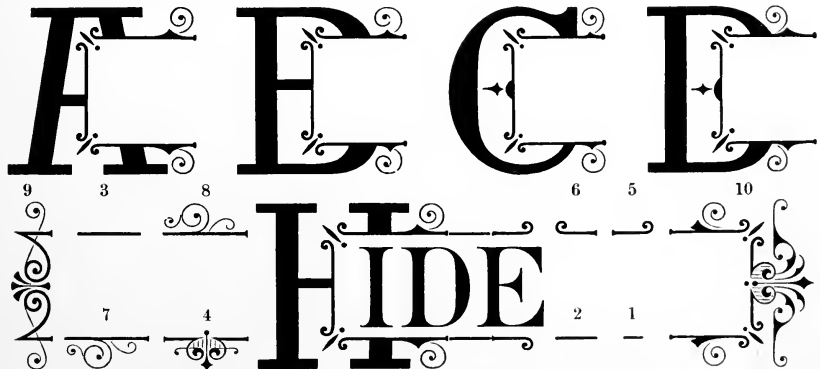

Electrotyped Initials

WAVERLEY SERIES NO. 74 B 1



ACORN SERIES NO. 71 B 1

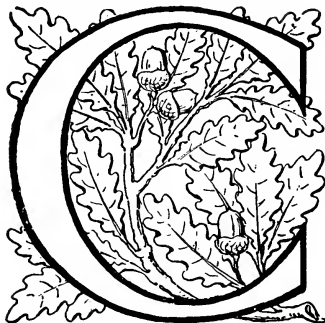

WAVERLEY SERIES NO. 75 B 1

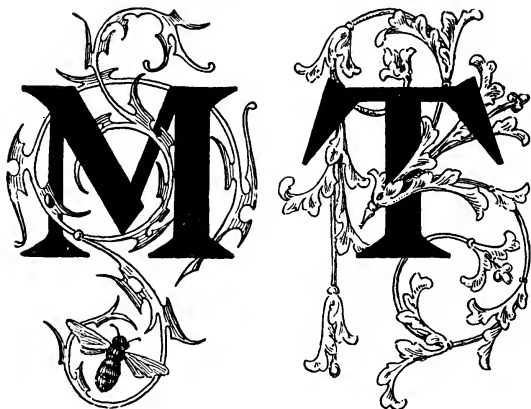

ACORN SERIES NO. 72 B 1



SERIES NO. 1158 B 11



SERIES NO. 425 B 4



ACORN SERIES NO. 73 B 1



PRICES:—Waverley Series, No. 74, Single Letter, 60 cts. Waverley Series, No. 75, Single Letter, 75 cts. Acorn Series, No. 71, per Set, \$20.00; Single Letter, \$1.00. Acorn Series, No. 72, per Set, \$15.00; Single Letter, 75 cts. Acorn Series, No. 73, per Set, \$12.00; Single Letter, 60 cts. Series No. 1158, per Set, \$6.00; Single Letter, 50 cts. Series No. 425, per Set, \$6.00; Single Letter, 30 cts.

For Morris and Jenson Initials, see page 517

Electrotyped Initials

INDEX INITIALS B 4

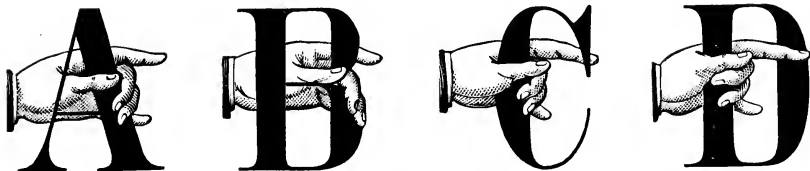

SERIES NO. 1159 B 11  
Each in Three Pieces

INDEX INITIALS B 4  
Second Series

SPHINX SERIES B 6

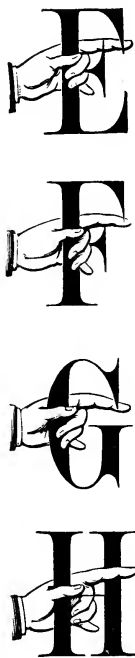

RENATE SERIES NO. 69 B 1



RENATE SERIES NO. 70 B 1



PRICES:—Index Initials, per Set, \$10.00; Single Letter, 50 cts. Index Initials, Second Series, per Set, \$8.00; Single Letter, 40 cts. Series No. 1159, per Set, with Ornaments, \$4.50; Single Letter, 40 cts. Sphinx Series, per Set, \$20.00; Single Letter, \$1.00. Renate Series, No. 69, per Set, \$15.00; Single Letter, 75 cts. Renate Series, No. 70, per Set, \$12.00; Single Letter, 60 cts.

For Morris and Jenson Initials, see page 517

**SELF SPACING PIECE FRACTIONS**

*These fonts are supplied with spaces, and can be used with ordinary as well as Self Spacing type*

12 POINT ROMAN NO. 31 PER FONT \$2 50  
**3<sup>12</sup>/<sub>16</sub>** 1234 **1<sup>12</sup>/<sub>34</sub>** 1/2 2/3 3/4 4/5 **5<sup>67</sup>/<sub>78</sub>** 5678

11 POINT ROMAN NO. 21 PER FONT \$2 50  
**5<sup>3</sup>/<sub>16</sub>** 1234 **1<sup>12</sup>/<sub>34</sub>** 1/4 2/3 3/4 1/16 **5<sup>67</sup>/<sub>78</sub>** 5678

10 POINT ROMAN NO. 17 PER FONT \$2 50  
**2<sup>12</sup>/<sub>87</sub>** 12345 **1<sup>12</sup>/<sub>345</sub>** 2/7 5/6 4/5 7/8 **6<sup>78</sup>/<sub>90</sub>** 67890

9 POINT ROMAN NO. 32 PER FONT \$2 50  
**7<sup>1</sup>/<sub>16</sub>** 12345 **1<sup>12</sup>/<sub>345</sub>** 1/9 3/8 2/7 5/6 1/5 7/8 **6<sup>78</sup>/<sub>90</sub>** 67890

8 POINT ROMAN NO. 18 PER FONT \$2 50  
**3<sup>2</sup>/<sub>32</sub>** 12345 **1<sup>12</sup>/<sub>345</sub>** 2/7 5/6 3/4 7/8 5/9 1/6 5/8 **6<sup>78</sup>/<sub>90</sub>** 67890

7 POINT ROMAN NO. 23 PER FONT \$2 50  
**2<sup>3</sup>/<sub>64</sub>** 12345 **1<sup>12</sup>/<sub>345</sub>** 1/2 2/7 1/5 3/5 1/6 5/7 5/8 7/8 **5<sup>678</sup>/<sub>90</sub>** 567890

6 POINT ROMAN NO. 20 PER FONT \$2 50  
**3<sup>9</sup>/<sub>157</sub>** 12345 **1<sup>12</sup>/<sub>345</sub>** 1/9 3/8 2/7 5/6 1/5 3/7 2/3 1/2 5/8 7/8 **5<sup>678</sup>/<sub>90</sub>** 567890

12 POINT OLD STYLE NO. 26 PER FONT \$2 50  
**3<sup>2</sup>/<sub>43</sub>** 12345 **1<sup>12</sup>/<sub>345</sub>** 1/2 2/3 3/4 **1<sup>2345</sup>/<sub>7777</sub>** 12345

11 POINT OLD STYLE NO. 25 PER FONT \$2 50  
**7<sup>2</sup>/<sub>43</sub>** 12345 **1<sup>12</sup>/<sub>345</sub>** 1/2 2/3 4/5 1/16 **1<sup>2345</sup>/<sub>7777</sub>** 12345

10 POINT OLD STYLE NO. 24 PER FONT \$2 50  
**5<sup>3</sup>/<sub>87</sub>** 12345 **6<sup>78</sup>/<sub>90</sub>** 2/7 5/6 3/4 7/8 **1<sup>2345</sup>/<sub>7777</sub>** 12345

9 POINT OLD STYLE NO. 28 PER FONT \$2 50  
**5<sup>10</sup>/<sub>32</sub>** 12345 **1<sup>12</sup>/<sub>345</sub>** 1/4 3/4 1/5 2/5 3/5 4/5 **1<sup>2345</sup>/<sub>7777</sub>** 12345

8 POINT OLD STYLE NO. 22 PER FONT \$2 50  
**2<sup>5</sup>/<sub>32</sub>** 12345 **1<sup>12</sup>/<sub>345</sub>** 1/4 1/2 3/4 1/5 2/5 4/5 1/7 **1<sup>2345</sup>/<sub>7777</sub>** 12345

6 POINT OLD STYLE NO. 27 PER FONT \$2 50  
**4<sup>6</sup>/<sub>357</sub>** 12345 **1<sup>12</sup>/<sub>345</sub>** 1/4 3/4 1/5 2/5 3/5 1/7 3/7 5/7 1/8 **1<sup>2345</sup>/<sub>7777</sub>** 12345

PIECE FRACTIONS

4-12

12 POINT NO. 120 PER LB. \$2 00

1	2	3	4	5	6	7	8	9	0
$\frac{1}{1}$	$\frac{2}{2}$	$\frac{3}{3}$	$\frac{4}{4}$	$\frac{5}{5}$	$\frac{6}{6}$	$\frac{7}{7}$	$\frac{8}{8}$	$\frac{9}{9}$	$\frac{0}{0}$
$\frac{2}{5}$	$\frac{3}{16}$	$\frac{5}{36}$	$\frac{13}{68}$	$\frac{9}{100}$	$\frac{33}{100}$				

11 POINT NO. 120 PER LB. \$2 40

1	2	3	4	5	6	7	8	9	0
$\frac{1}{1}$	$\frac{2}{2}$	$\frac{3}{3}$	$\frac{4}{4}$	$\frac{5}{5}$	$\frac{6}{6}$	$\frac{7}{7}$	$\frac{8}{8}$	$\frac{9}{9}$	$\frac{0}{0}$
$\frac{2}{3}$	$\frac{3}{7}$	$\frac{5}{9}$	$\frac{4}{25}$	$\frac{35}{86}$	$\frac{7}{234}$	$\frac{68}{275}$			

10 POINT NO. 120 PER LB. \$2 80

1	2	3	4	5	6	7	8	9	0
$\frac{1}{1}$	$\frac{2}{2}$	$\frac{3}{3}$	$\frac{4}{4}$	$\frac{5}{5}$	$\frac{6}{6}$	$\frac{7}{7}$	$\frac{8}{8}$	$\frac{9}{9}$	$\frac{0}{0}$
$\frac{2}{5}$	$\frac{3}{20}$	$\frac{4}{68}$	$\frac{7}{90}$	$\frac{9}{10}$	$\frac{24}{160}$	$\frac{45}{200}$			

9 POINT NO. 120 PER LB. \$3 20

1	2	3	4	5	6	7	8	9	0
$\frac{1}{1}$	$\frac{2}{2}$	$\frac{3}{3}$	$\frac{4}{4}$	$\frac{5}{5}$	$\frac{6}{6}$	$\frac{7}{7}$	$\frac{8}{8}$	$\frac{9}{9}$	$\frac{0}{0}$
$\frac{2}{5}$	$\frac{4}{27}$	$\frac{5}{36}$	$\frac{13}{68}$	$\frac{12}{160}$	$\frac{17}{380}$	$\frac{33}{1000}$			

8 POINT NO. 120 PER LB. \$3 60

1	2	3	4	5	6	7	8	9	0
$\frac{1}{1}$	$\frac{2}{2}$	$\frac{3}{3}$	$\frac{4}{4}$	$\frac{5}{5}$	$\frac{6}{6}$	$\frac{7}{7}$	$\frac{8}{8}$	$\frac{9}{9}$	$\frac{0}{0}$
$\frac{1}{4}$	$\frac{2}{5}$	$\frac{3}{17}$	$\frac{4}{45}$	$\frac{6}{38}$	$\frac{23}{150}$	$\frac{8}{497}$	$\frac{31}{1500}$	$\frac{97}{1500}$	

7 POINT NO. 40 PER FONT \$5 00

1	2	3	4	5	6	7	8	9	0
$\frac{1}{1}$	$\frac{2}{2}$	$\frac{3}{3}$	$\frac{4}{4}$	$\frac{5}{5}$	$\frac{6}{6}$	$\frac{7}{7}$	$\frac{8}{8}$	$\frac{9}{9}$	$\frac{0}{0}$
$\frac{1}{2}$	$\frac{2}{5}$	$\frac{3}{7}$	$\frac{4}{28}$	$\frac{4}{45}$	$\frac{6}{82}$	$\frac{23}{78}$	$\frac{9}{245}$	$\frac{24}{287}$	$\frac{33}{4785}$

6 POINT NO. 120 PER LB. \$5 00

1	2	3	4	5	6	7	8	9	0
$\frac{1}{1}$	$\frac{2}{2}$	$\frac{3}{3}$	$\frac{4}{4}$	$\frac{5}{5}$	$\frac{6}{6}$	$\frac{7}{7}$	$\frac{8}{8}$	$\frac{9}{9}$	$\frac{0}{0}$
$\frac{1}{2}$	$\frac{3}{7}$	$\frac{4}{27}$	$\frac{5}{38}$	$\frac{8}{45}$	$\frac{23}{74}$	$\frac{9}{100}$	$\frac{24}{150}$	$\frac{63}{230}$	$\frac{33}{1000}$

CANCELLED FIGURES

4-15

11 POINT NO. 40 PER LB. 70 CTS.

*1 2 3 4 5 6 7 8 9 0*

10 POINT NO. 150 PER LB. 74 CTS.

*1 2 3 4 5 6 7 8 9 0*

9 POINT NO. 40 PER LB. 80 CTS.

*1 2 3 4 5 6 7 8 9 0*

8 POINT NO. 150 PER LB. 90 CTS.

*1 2 3 4 5 6 7 8 9 0*

Superior and Inferior Letters and Figures

4-15

Prices quoted are per pound of either

12 POINT NO. 150 PER LB. \$1 16

abcdefghijklm nopqrstuvwxyz  
1234567890  
1234567890

11 POINT NO. 150 PER LB. \$1 22

abcdefghijklm nopqrstuvwxyz  
1234567890  
1234567890

10 POINT NO. 150 PER LB. \$1 30

abcdefghijklm nopqrstuvwxyz  
1234567890  
1234567890

9 POINT NO. 150 PER LB. \$1 44

abcdefghijklm nopqrstuvwxyz  
1234567890  
1234567890

8 POINT NO. 150 PER LB. \$1 60

abcdefghijklm nopqrstuvwxyz  
1234567890  
1234567890

7 POINT NO. 150 PER LB. \$1 80

abcdefghijklm nopqrstuvwxyz  
1234567890  
1234567890

6 POINT NO. 150 PER LB. \$2 00

abcdefghijklm nopqrstuvwxyz  
1234567890  
1234567890

5½ POINT NO. 40 PER LB. \$2 40

abcdefghijklm nopqrstuvwxyz  
1234567890  
1234567890

**Special Figures**

B 12

8 POINT TWO-THIRD FIGURES  
PER LB. 90 CTS.

1 2 3 4 5 6 7 8 9 0 \$

7 POINT TWO-THIRD FIGURES  
PER LB. \$1 00

1 2 3 4 5 6 7 8 9 0 \$

6 POINT TWO-THIRD FIGURES  
PER LB. \$1 16

1 2 3 4 5 6 7 8 9 0 \$

5½ POINT TWO-THIRD FIGURES  
PER LB. \$1 44

1 2 3 4 5 6 7 8 9 0 \$

5 POINT TWO-THIRD FIGURES  
PER LB. \$1 80

1 2 3 4 5 6 7 8 9 0 \$

6 POINT EN FIGURES  
PER LB. \$1 16

1 2 3 4 5 6 7 8 9 0

5½ POINT EN FIGURES  
PER LB. \$1 44

1 2 3 4 5 6 7 8 9 0

**Special Logotypes**

B 15

*Special Logotypes will be engraved and cast to order. The following are a few examples of those we have matrices for and can supply to order:*

8 POINT

A.M. P.M. <sup>A</sup>M <sup>P</sup>M A.L. LV. “ ↘ Ed. \*

6 POINT

am pm A.M P.M A.M. P.M.  
Ar. Lv. TEX “ A.M. P.M.  
ST LOUIS SE AM PM

5½ POINT

1 Mile. AM PM <sup>A</sup> <sup>M</sup> Fig.

**Full Face Fractions**

B 15

8 POINT NO. 7 1 LB. FONT 90 CTS.

$\frac{1}{4}$   $\frac{1}{2}$   $\frac{3}{4}$   $\frac{1}{3}$   $\frac{2}{3}$   $\frac{1}{8}$   $\frac{3}{8}$   $\frac{5}{8}$   $\frac{7}{8}$

6 POINT NO. 7 1 LB. FONT \$1 16

$\frac{1}{4}$   $\frac{1}{2}$   $\frac{3}{4}$   $\frac{1}{3}$   $\frac{2}{3}$   $\frac{1}{8}$   $\frac{3}{8}$   $\frac{5}{8}$   $\frac{7}{8}$

**Special Fractions**

B 4 AND 15

8 POINT NO. 1528 1 LB. FONT 90 CTS.

$\frac{1}{4}$   $\frac{1}{2}$   $\frac{3}{4}$   $\frac{1}{3}$   $\frac{2}{3}$   $\frac{1}{8}$   $\frac{3}{8}$   $\frac{5}{8}$   $\frac{7}{8}$

7 POINT NO. 1528 1 LB. FONT \$1 00

$\frac{1}{4}$   $\frac{1}{2}$   $\frac{3}{4}$   $\frac{1}{3}$   $\frac{2}{3}$   $\frac{1}{8}$   $\frac{3}{8}$   $\frac{5}{8}$   $\frac{7}{8}$

6 POINT NO. 1528 1 LB. FONT \$1 16

$\frac{1}{4}$   $\frac{1}{2}$   $\frac{3}{4}$   $\frac{1}{3}$   $\frac{2}{3}$   $\frac{1}{8}$   $\frac{3}{8}$   $\frac{5}{8}$   $\frac{7}{8}$

5½ POINT NO. 1528 1 LB. FONT \$1 44

$\frac{1}{4}$   $\frac{1}{2}$   $\frac{3}{4}$   $\frac{1}{3}$   $\frac{2}{3}$   $\frac{1}{8}$   $\frac{3}{8}$   $\frac{5}{8}$   $\frac{7}{8}$

6 POINT NO. 154 1 LB. FONT \$1 16

$\frac{1}{4}$   $\frac{1}{2}$   $\frac{3}{4}$   $\frac{1}{3}$   $\frac{2}{3}$   $\frac{1}{8}$   $\frac{3}{8}$   $\frac{5}{8}$   $\frac{7}{8}$

5½ POINT NO. 154 1 LB. FONT \$1 44

$\frac{1}{4}$   $\frac{1}{2}$   $\frac{3}{4}$   $\frac{1}{3}$   $\frac{2}{3}$   $\frac{1}{8}$   $\frac{3}{8}$   $\frac{5}{8}$   $\frac{7}{8}$

5½ POINT NO. 40 1 LB. FONT \$1 44

ONE-AND-A-HALF EM FRACTIONS

$\frac{1}{16}$   $\frac{3}{16}$   $\frac{5}{16}$   $\frac{7}{16}$   $\frac{9}{16}$   $\frac{11}{16}$   $\frac{13}{16}$   $\frac{15}{16}$

**Caledonian Fractions**

B 15

18 POINT 1 LB. FONT 60 CTS.

$\frac{1}{4}$   $\frac{1}{2}$   $\frac{3}{4}$   $\frac{2}{3}$

**Poster Roman No. 123 Fractions**

B 12

30 POINT 1 LB. FONT 56 CTS.

$\frac{1}{2}$   $\frac{3}{4}$   $\frac{1}{3}$   $\frac{2}{3}$

24 POINT 1 LB. FONT 60 CTS.

$\frac{1}{4}$   $\frac{1}{2}$   $\frac{3}{4}$   $\frac{1}{3}$   $\frac{2}{3}$

18 POINT 1 LB. FONT 60 CTS.

$\frac{1}{4}$   $\frac{1}{2}$   $\frac{3}{4}$   $\frac{1}{3}$   $\frac{2}{3}$

12 POINT 1 LB. FONT 66 CTS

$\frac{1}{4}$   $\frac{1}{2}$   $\frac{3}{4}$

**Doric Fractions** B 12

42 POINT 1 LB. FONT 54 CTS.

$\frac{1}{4}$   $\frac{1}{2}$   $\frac{3}{4}$

36 POINT 1 LB. FONT 56 CTS.

$\frac{1}{4}$   $\frac{1}{2}$   $\frac{3}{4}$

30 POINT 1 LB. FONT 56 CTS.

$\frac{1}{4}$   $\frac{1}{2}$   $\frac{3}{4}$

24 POINT 1 LB. FONT 56 CTS.

$\frac{1}{4}$   $\frac{1}{2}$   $\frac{3}{4}$

**Poster Roman No. 120 Fractions** B 12

48 POINT 1 LB. FONT 54 CTS.

$\frac{1}{4}$   $\frac{1}{2}$   $\frac{3}{4}$

30 POINT 1 LB. FONT 56 CTS.

$\frac{1}{4}$   $\frac{1}{2}$   $\frac{3}{4}$

24 POINT 1 LB. FONT 56 CTS.

$\frac{1}{4}$   $\frac{1}{2}$   $\frac{3}{4}$   $\frac{1}{3}$   $\frac{2}{3}$

**Gothic Cond Fractions** B 3

24 POINT 1 LB. FONT 56 CTS.

$\frac{1}{4}$   $\frac{1}{2}$   $\frac{3}{4}$   $\frac{1}{3}$   $\frac{2}{3}$   $\frac{5}{8}$   $\frac{7}{8}$

Also made in 12 Point at 66 cts., 18 Point at 60 cts., and 30 Point at 56 cts. per pound.

**De Vinne Fractions** B 15

Each font has same assortment as shown in 8 Point specimen.

24 POINT PER FONT 50 CTS

$\frac{1}{4}$   $\frac{1}{2}$   $\frac{3}{4}$   $\frac{1}{3}$

18 POINT PER FONT 50 CTS.

$\frac{2}{3}$   $\frac{1}{8}$   $\frac{3}{8}$   $\frac{5}{8}$   $\frac{7}{8}$

14 POINT PER FONT 50 CTS.

$\frac{1}{4}$   $\frac{1}{2}$   $\frac{3}{4}$   $\frac{1}{3}$   $\frac{2}{3}$   $\frac{1}{8}$

12 POINT PER FONT 50 CTS.

$\frac{2}{3}$   $\frac{1}{8}$   $\frac{3}{8}$   $\frac{5}{8}$   $\frac{7}{8}$   $\phi$   $\%$

10 POINT PER FONT 50 CTS.

$\frac{1}{4}$   $\frac{1}{2}$   $\frac{3}{4}$   $\frac{1}{3}$   $\frac{2}{3}$   $\frac{1}{8}$   $\frac{3}{8}$   $\frac{5}{8}$

8 POINT PER FONT 50 CTS.

$\frac{1}{4}$   $\frac{1}{2}$   $\frac{3}{4}$   $\frac{1}{3}$   $\frac{2}{3}$   $\frac{1}{8}$   $\frac{3}{8}$   $\frac{5}{8}$   $\frac{7}{8}$   $\phi$   $\%$

7 POINT PER FONT 50 CTS.

$\frac{1}{4}$   $\frac{1}{2}$   $\frac{3}{4}$   $\frac{1}{3}$   $\frac{2}{3}$   $\frac{1}{8}$   $\frac{3}{8}$   $\frac{5}{8}$   $\frac{7}{8}$   $\phi$   $\%$

6 POINT PER FONT 50 CTS.

$\frac{1}{4}$   $\frac{1}{2}$   $\frac{3}{4}$   $\frac{1}{3}$   $\frac{2}{3}$   $\frac{1}{8}$   $\frac{3}{8}$   $\frac{5}{8}$   $\frac{7}{8}$   $\phi$   $\%$

**Gothic Fractions** B 3

Each font has same assortment as shown in 6 Point specimen.

18 POINT 1 LB. FONT 60 CTS.

$\frac{1}{4}$   $\frac{1}{2}$   $\frac{3}{4}$   $\frac{1}{3}$   $\frac{2}{3}$   $\frac{1}{8}$

12 POINT 1 LB. FONT 66 CTS.

$\frac{3}{4}$   $\frac{1}{3}$   $\frac{2}{3}$   $\frac{1}{8}$   $\frac{3}{8}$   $\frac{5}{8}$   $\frac{7}{8}$

6 POINT 1 LB. FONT \$1 16

$\frac{1}{4}$   $\frac{1}{2}$   $\frac{3}{4}$   $\frac{1}{3}$   $\frac{2}{3}$   $\frac{1}{8}$   $\frac{3}{8}$   $\frac{5}{8}$   $\frac{7}{8}$

**Astronomical Signs**

B 15

24 POINT

8 CENTS EACH



20 POINT

8 CENTS EACH



16 POINT

6 CENTS EACH



12 POINT NO. 3

PER FONT \$3 00

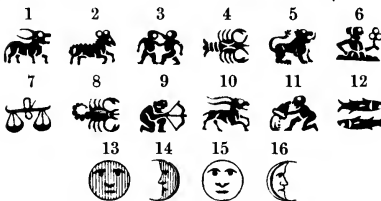

12 POINT NO. 2

PER FONT \$3 00



11 POINT NO. 2

PER FONT \$3 00



10 POINT NO. 2

PER FONT \$3 00



9 POINT NO. 2

PER FONT \$2 25



8 POINT NO. 2

PER FONT \$2 00

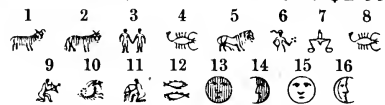

14 POINT NO. 1

PER FONT \$5 40

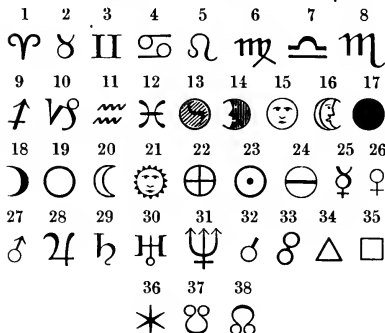

12 POINT NO. 1

PER FONT \$4 50

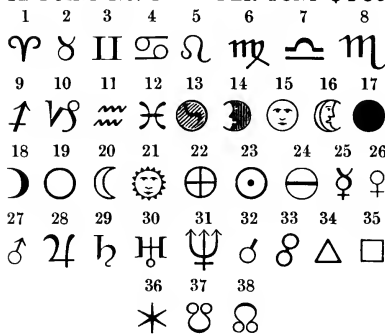

11 POINT NO. 1

PER FONT \$4 50

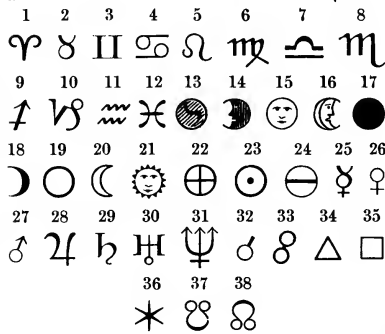



COPPER ALLOY TYPE

10 POINT No. 1 PER FONT \$4 75

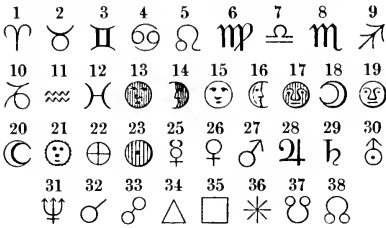

9 POINT No. 1 PER FONT \$5 00

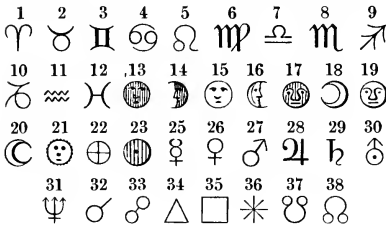

8 POINT No. 1 PER FONT \$5 00

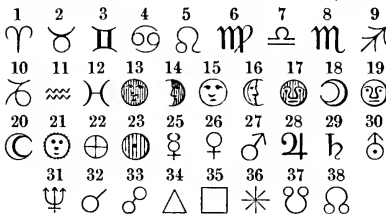

7 POINT No. 1 PER FONT \$2 75

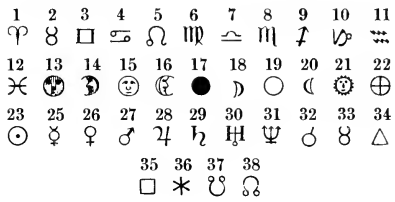

6 POINT No. 1 PER FONT \$2 25

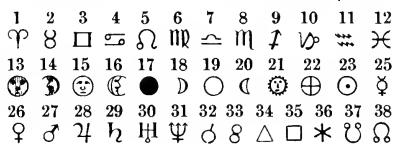

Piece Accents 15

6 POINT SHADED No. 150 \$0 25



6 POINT No. 150 \$0 50



4 POINT No. 150 \$0 40



3 POINT No. 150 \$0 30



ACCENTS

The American Type Founders' Company makes the most complete assortment of accented letters in America for all foreign languages.

Type with correct accented letters for French, German, Spanish, Portuguese, Italian, Norwegian, Swedish, Danish, Polish, Hungarian and Bohemian can be furnished, and lists of same will be sent on application.

**Medical Signs**

B 15

12 POINT PER FONT \$1 00

3 3 9 R

11 POINT PER FONT \$1 00

3 3 9 R

10 POINT PER FONT \$1 00

3 3 9 R

9 POINT PER FONT \$1 00

3 3 9 R

8 POINT PER FONT \$1 00

3 3 9 R

7 POINT PER FONT \$1 00

3 3 9 R

6 POINT PER FONT \$1 00

3 3 9 R

**Commercial Signs**

B 15

12 POINT PER LB. \$1 16

Ⓕ @ lb % ¢

11 POINT PER LB. \$1 22

Ⓕ @ lb % ¢

10 POINT PER LB. \$1 30

Ⓕ @ lb % ¢

9 POINT PER LB. \$1 44

Ⓕ @ lb % ¢

8 POINT PER LB. \$1 60

Ⓕ @ lb % ¢

7 POINT PER LB. \$1 80

Ⓕ @ lb % ¢

6 POINT PER LB. \$2 00

Ⓕ @ lb % ¢

5½ POINT PER LB. \$2 40

Ⓕ @ lb % ¢

**Algebraic Signs**

B 15

12 POINT PER FONT \$1 16

51 52 53 54 55 56 57 59 60  
+ - × ÷ = ∴ ± □ △

61 62 63 64 65 66 67  
< √ √³ : ∴ ↗ ↪

11 POINT PER FONT \$1 22

51 52 53 54 55 56 57 59  
+ - × ÷ = ∴ ± □

60 61 62 63 64 65 66 67  
△ < √ √³ : ∴ ↗ ↪

10 POINT PER FONT \$1 30

51 52 53 54 55 56 57 59  
+ - × ÷ = ∴ ± □

60 61 62 63 64 65 66 67  
△ < √ √³ : ∴ ↗ ↪

9 POINT PER FONT \$1 44

51 52 53 54 55 56 57 59  
+ - × ÷ = ∴ ± □

60 61 62 63 64 65 66 67  
△ < √ √³ : ∴ ↗ ↪

8 POINT PER FONT \$1 60

51 52 53 54 55 56 57 59 60  
+ - × ÷ = ∴ ± □ △

61 62 63 64 65 66 67  
< √ √³ : ∴ ↗ ↪

7 POINT PER FONT \$1 80

51 52 53 54 55 56 57 58 59 60 61 62  
+ - × ÷ = ∴ ± □ □ △ < √

63 64 65 66  
√³ : ∴ ↗

6 POINT PER FONT \$2 00

51 52 53 54 55 56 57 58 59 60 61 62  
+ - × ÷ = ∴ ± □ □ △ < √

63 64 65 66  
√³ : ∴ ↗

5½ POINT PER FONT \$2 40

51 52 53 54 55 56 57 58 59 60 61 62  
+ - × ÷ = ∴ ± □ □ △ < √

63 64 65 66  
√³ : ∴ ↗

MISCELLANEOUS SIGNS

12  
Cast to order

6 POINT																PER LB. \$2 00		
550	551	552	553	554	555	556	557	558	559	560	561	562	563	564	565	566	567	568
—	=	+	×	÷	#	±	□	▭	△	<	>	~	√		≅	∠	L	∞
569	570	571	572	573	574	575	576	577	578	579	580	581	582	583	584	585	586	587
⌈	⌋	∞	::	:-	:	○	▭	√	+	°	°	'	"	%	‰	¢	₤	₧
588	589	590	591	592	593	594	595	596	597	598	599	600	601	602	603	604	605	606
3	∅	∅	∅	∅	∅	∅	∅	∅	∅	∅	∅	∅	∅	∅	∅	∅	∅	∅
607	608	609	610	611	612	613	614	615	616	617	618	619	620	621	622	623	624	625
∅	∅	∅	∅	∅	∅	∅	∅	∅	∅	∅	∅	∅	∅	∅	∅	∅	∅	∅
626	627	628	629	630	631	632	633	634	635	636	637	638	639	640	641	642	643	644
∅	∅	∅	∅	∅	∅	∅	∅	∅	∅	∅	∅	∅	∅	∅	∅	∅	∅	∅

8 POINT																PER LB. \$1 60		
645	646	647	648	649	650	651	652	653	654	655	656	657	658	659	660	661	662	663
—	=	+	×	÷	∴	±	□	▭	△	<	>	~	√	L	∠	≅	⌈	⌋
664	665	666	667	668	669	670	671	672	673	674	675	676	677	678	679	680	681	682
::	:-	:	○	▭	°	°	'	"	‰	%	¢	₤	₧	₧	₧	∅	∅	∅
683	684	685	686	687	688	689	690	691	692	693	694	695	696	697	698	699	700	701
∅	∅	∅	∅	∅	∅	∅	∅	∅	∅	∅	∅	∅	∅	∅	∅	∅	∅	∅
702	703	704	705	706	707	708	709	710	711	712	713	714	715	716	717	718	719	720
∅	∅	∅	∅	∅	∅	∅	∅	∅	∅	∅	∅	∅	∅	∅	∅	∅	∅	∅
721	722	723	724	725	726	727	728	729	730	731	732	733	734	735	736	737	738	
∅	∅	∅	∅	∅	∅	∅	∅	∅	∅	∅	∅	∅	∅	∅	∅	∅	∅	∅

10 POINT																PER LB. \$1 30
739	740	741	742	743	744	745	746	747	748	749	750	751	752	753	754	755
—	=	+	×	÷	∴	±	□	▭	△	>	<	~	√		≅	∠
756	757	758	759	760	761	762	763	764	765	766	767	768	769	770	771	772
⌈	⌋	⌋	∞	::	:-	:	○	▭	°	'	"	‰	‰	¢	@	₧
773	774	775	776	777	778	779	780	781	782	783	784	785	786	787	788	789
∅	∅	∅	∅	∅	∅	∅	∅	∅	∅	∅	∅	∅	∅	∅	∅	∅
790	791	792	793	794	795	796	797	798	799	800	801	802	803	804		
∅	∅	∅	∅	∅	∅	∅	∅	∅	∅	∅	∅	∅	∅	∅		
705	806	807	808	809	810	811	812	813	814	815	816	817	818	819	820	821
∅	∅	∅	∅	∅	∅	∅	∅	∅	∅	∅	∅	∅	∅	∅	∅	∅
822	823	824	825	826	827	828	829	830	831	832	833	834	835	836	837	838
∅	∅	∅	∅	∅	∅	∅	∅	∅	∅	∅	∅	∅	∅	∅	∅	∅

In ordering, state size and number



**ELECTION SIGNS**

*For the various States using the Australian ballot. The signs are cast to the point system on metal bodies, therefore easily justified*

**Illinois and Iowa**



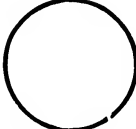

No. 2  No. 1  No. 5  20 POINT ANTIQUE EX. COND. NO. 150 10A \$2 00  
**INDEPENDENT TICKET.**

12 POINT ROMAN NO. 64 **JOHN J. BROWNING.** No. 3  No. 4 

**Indiana**

No. 10  No. 11  No. 12  No. 13 

**Kentucky and Michigan**

No. 2  No. 6  No. 7  No. 8 

**Wisconsin**

No. 9  No. 8 

**Ohio**

No. 14 

No.	Body	Each	50 or more Each	100 or more Each	No.	Body	Each	50 or more Each	100 or more Each
1—12	Point	\$.05	\$.04	\$.03	8—8	Point	\$.06	\$.04	\$.03
2—20	"	.06	.04	.03	9—30	"	.06	.04	.04
3—20	"	.06	.04	.03	10—30	"	.06	.04	.04
4—40	"	.15	.12	.10	11—30	"	.06	.04	.04
5—40	"	.15	.12	.10	12—30	"	.06	.04	.04
6—12	"	.06	.04	.03	13—30	"	.06	.04	.04
7—10	"	.06	.04	.03	14—72	"	.25	—	—

RECIPE MARKS

12-15

1E 6 cts. 	2E 6 cts. 	4E 6 cts. 	8E 10 cts. 	9E 10 cts. 	7E 8 cts. 	6E 8 cts. 	5E 6 cts. 	3E 6 cts. 
No. 2410F 20 cts. 	No. 2412F 15 cts. 	No. 2420F 15 cts. 	No. 2416F 20 cts. 	No. 12D 25 cts. 	No. 2415F 20 cts. 			

LOCUS SIGILLI

3-15

F. 25 cts. 	D. 30 cts. 	No. 513E. 25 cts. 	No. 664E. 25 cts. 
A. 10 cts. 	B. 15 cts. 	No. 311E. 25 cts. 	No. 453E. 25 cts. 

ENGRAVING BLANKS

12-15

No. 1E. 25 cts. 	No. 2E. 20 cts. 	No. 3E. 20 cts. 		
No. 4E. 15 cts. 	No. 5E. 15 cts. 	No. 6E. 10 cts. 	No. 7E. 15 cts. 	No. 8E. 15 cts. 
No. 9E. 25 cts. 	No. 10E. 10 cts. 	No. 11E. 10 cts. 	No. 12E. 10 cts. 	
No. 13E. 10 cts. 	No. 14E. 10 cts. 	No. 15E. 10 cts. 	No. 16E. 10 cts. 	No. 4148F. 15 cts. 

## United States Signal Flags

36 POINT

PER SET \$1 25

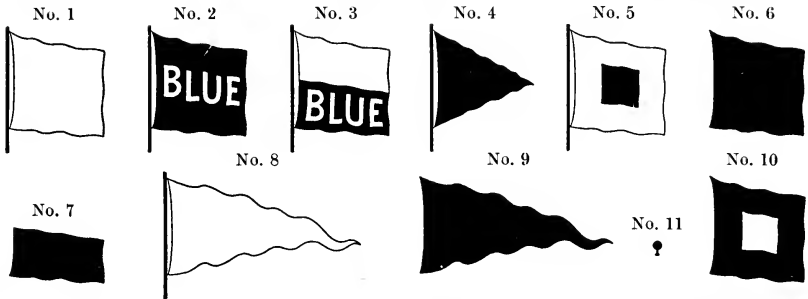

24 POINT

PER SET \$1 00

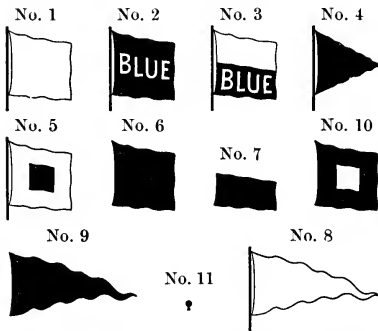

### Explanation of Weather Signals

**Clear or Fair Weather.**—WHITE, SQUARE FLAG. Print No. 1 in black. Displayed alone, indicates fair weather, stationary temperature; displayed with No. 4 above it, indicates fair weather, warmer; displayed with No. 4 below it, indicates fair weather, colder.

**Rain or Snow.**—BLUE, SQUARE FLAG. Print No. 6 in blue over No. 1 in black. Displayed alone, indicates rain or snow, stationary temperature; displayed with No. 4 above it, indicates rain or snow, warmer; displayed with No. 4 below it, indicates rain or snow, colder.

**Local Rain.**—WHITE AND BLUE, SQUARE FLAG. Print No. 7 in blue over lower half of No. 1 in black. Displayed alone, indicates local rain, stationary temperature; displayed with No. 4 above it, indicates local rain, warmer; displayed with No. 4 below it, indicates local rain, colder.

**Temperature Signal.**—BLACK, TRIANGULAR FLAG. Print No. 4 in black. Displayed in conjunction with other signals, as above described.

**Cold Wave.**—WHITE, SQUARE FLAG, BLACK CENTER. Print No. 5 in black. Displayed alone indicates temperature will fall 20° or more, to a minimum of 32° or less. When displayed with No. 1, indicates fair weather, cold wave.

### Explanation of Wind Signals

**Storm.**—RED, SQUARE FLAG, BLACK CENTER. Print No. 10 in red over No. 5 in black. When displayed, indicates that storm of marked violence is expected. **Hurricane.**—Indicated by two Storm Flags displayed one above the other.

**Cautionary.**—RED, SQUARE FLAG, WHITE CENTER. Print No. 10 in red over No. 1 in black. When displayed, indicates that the winds expected will not be so severe. Well-found, seaworthy vessels can meet them without danger.

**Easterly Winds.**—RED PENNANT. Print No. 9 in red over No. 8 in black. When displayed above either Cautionary or Storm Flags, indicates northeasterly winds; when below, southeasterly; when alone, that special information of storms is to be obtained by calling on Signal Officer in charge.

**Westerly Winds.**—WHITE PENNANT. Print No. 8 in black. Displayed above either Cautionary or Storm Flags, indicates northwesterly winds; below, southwesterly.

## Weather Indicators

36 POINT

PER FONT \$1 75

EACH 15 CENTS

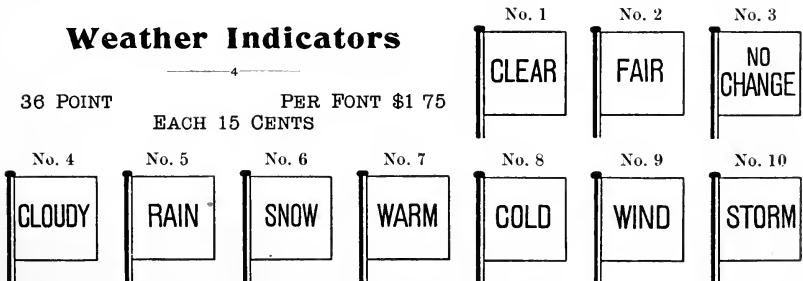

INDEX CUTS

3-12-15

No. 3846B  
30 cts.



No. 4017F. 25 cts.



No. 4018F. 25 cts.



No. 3847B  
30 cts.



No. 4015F. 20 cts.



No. 4016F. 20 cts.



No. 1072E. 12 cts.



No. 1073E. 12 cts.



No. 4013F  
15 cts.



No. 4012F  
10 cts.



No. 4009F  
10 cts.



No. 4007F  
10 cts.



No. 4008F  
10 cts.



No. 4010F  
10 cts.



No. 4011F  
10 cts.



No. 4014F  
15 cts.



No. 4001F  
5 cts.



No. 4003F  
5 cts.



No. 4006F  
5 cts.



No. 4005F  
5 cts.



No. 4004F  
5 cts.



No. 4002F  
5 cts.



No. 1079E. 30 cts.



No. 1078E. 30 cts.



No. 3852B  
25 cts.



No. 1070E. 15 cts.



No. 1052E  
8 cts.

No. 1053E  
8 cts.



No. 1071E. 15 cts.



No. 3853B  
25 cts.



No. 1074E. 20 cts.



No. 1075E. 20 cts.





**Five-Pointed Black Stars**

Nos. 201F to 215F put up in fonts containing four of each No., \$1.00

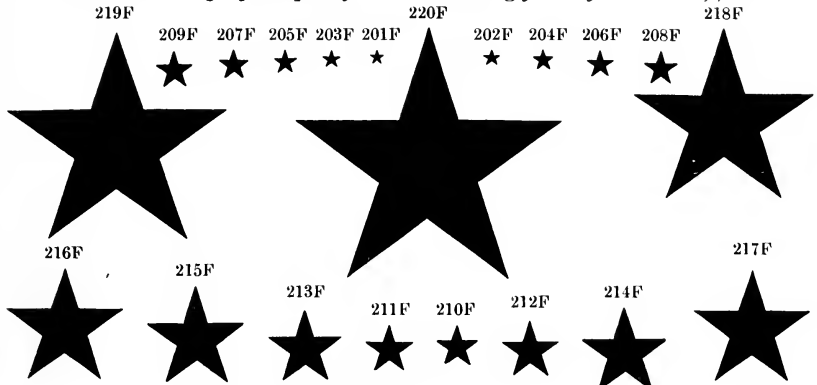

Nos. 201F to 210F, 15c. per set of four; Nos. 211F and 212F, 20c. per set of four; Nos. 213F to 215F, 30c. per set of four; Nos. 216F and 217F, 15c. each; Nos. 218F and 219F, 20c. each; No. 220F, 25c. each.

**Five-Pointed White Stars**

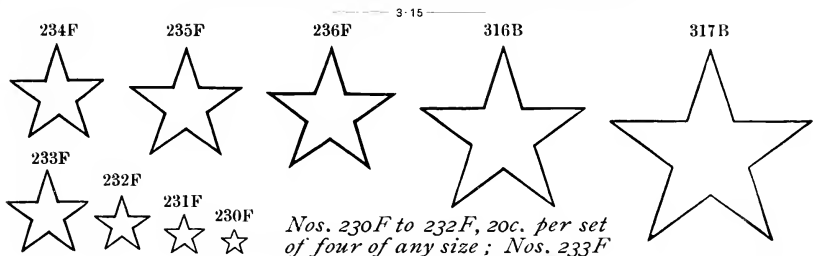

Nos. 230F to 232F, 20c. per set of four of any size; Nos. 233F to 235F, 10c. each; Nos. 236F and 316B, 15c. each; No. 317B, 20c. each.

**Maltese Crosses**

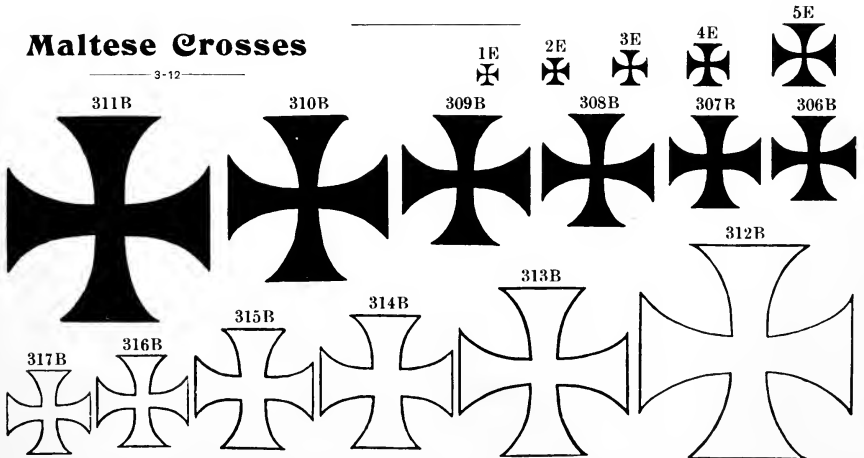

Nos. 1E to 4E, 15c. per set of four each; Nos. 5E, 306B, 307B, 310B, 317B, 10c. each; Nos. 308B, 309B, 314B, 315B, 15c. each; Nos. 310B, 313B, 20c. each; Nos. 311B, 312B, 25c. each.

**CHESSMEN AND CHECKERS**

3-15

16 POINT CHESSMEN Per Font, with Rules, \$4 80

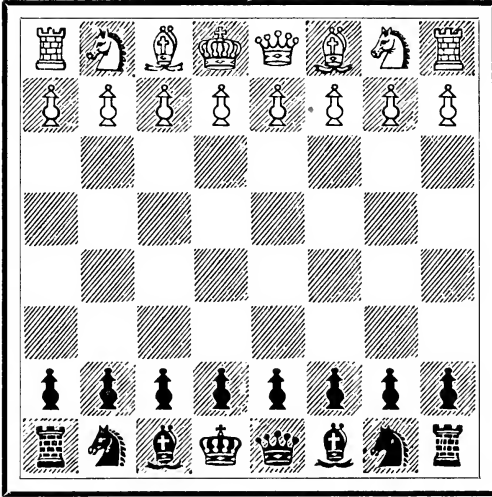

20 POINT CHESSMEN \$4 80  
Complete, with Rules



24 POINT CHECKERS Per Font, with Rules, \$3 40  
29 28 25 27 26



16 POINT CHECKERS Per Font, with Rules, \$3 40

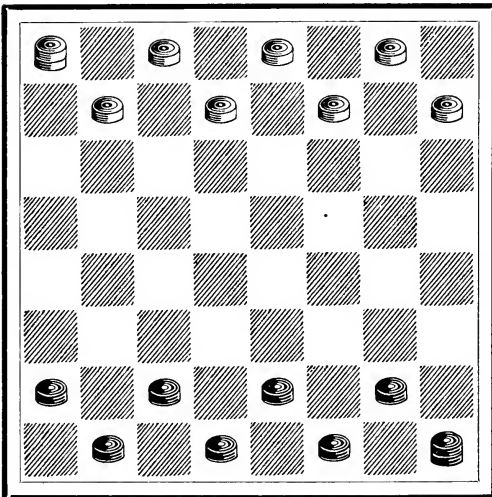

20 POINT CHECKERS \$3 40  
Complete, with Rules

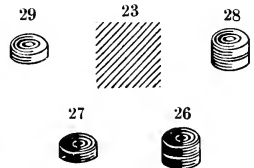

*24 Point Chessmen at \$4.80 per font, and 11 Point Checkers at \$2.00 per font, also made*

**CARD PIPS**

32 POINT SERIES 1  
FONT OF 52 PIECES, \$5 00

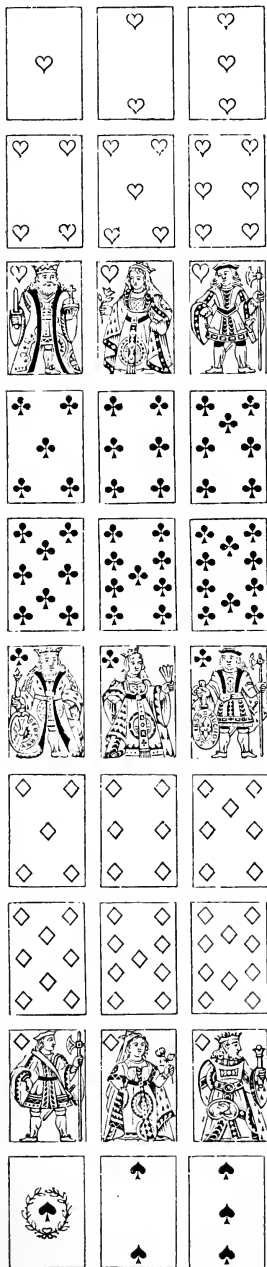

**CARD INDICATORS**

24 POINT PER FONT \$1 75



10 POINT PER LB. \$1 30 12 POINT PER LB. \$1 16



6 POINT PER FONT \$5 50

3 ♠	<u>A ♠</u>	4 ♠	♣ 4
6 ♦	J ♦	K ♦	<u>A ♦</u>
7 ♦	9 ♦	2 ♦	<u>Q ♦</u>
♥ 9	<u>♥ 10</u>	5 ♦	10 ♦
♣ 2	<u>♣ A</u>	♣ 3	♣ 7
<u>♥ 2</u>	♣ J	♣ Q	♣ K
♥ 3	♥ 6	<u>♥ A</u>	♥ 4
2 ♠	♣ 5	K ♠	<u>♥ 5</u>
5 ♠	♣ 6	7 ♠	<u>8 ♦</u>
6 ♠	♣ 9	8 ♠	<u>4 ♦</u>
9 ♠	10 ♣	10 ♠	<u>3 ♦</u>
♥ Q	<u>♥ K</u>	J ♠	♣ 8
♥ 7	♥ 8	Q ♠	♥ J

Complete with Rules, Leads and Spaces.

**WHIST MARKERS**

18 POINT PER LB. \$1 00

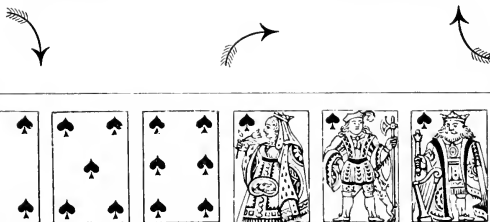

**Copper Alloy Fine-Dot Leaders**

12

These are used as a substitute for Dotted Brass Rule, and save the time spent in justification. Made on 6, 7, 8, 9, 10, 11 and 12 Point bodies. When ordering, state the type (if our make) they are required to line with, or send sample cap "H" or lower-case "m." The following example shows Fine-Dot Leaders lining with 8 Point Law Italic No. 120:

*Personally appeared, this.....day of  
 .....A. D. 189....., before me, a boy  
 known as.....  
 and deposed that, although he is not at present  
 able to.....correctly the words  
 ....., it is not because he never  
 knew how.*

*.....Notary Public.*

6 Point	Per pound	\$o 64	9 Point	Per pound	\$o 48	12 Point	Per pound	\$o 42
7 "	"	56	10 "	"	46	Put up in any size font required.		
8 "	"	52	11 "	"	44			

**COPPER ALLOY IMPRINTS**

15

Cast in one piece, any of the faces here shown, at the following prices:  
 100 of any one kind for \$8.00 net.\*      50 of any one kind for \$5.00 net.\*

- STYLE 1  
COMMERCIAL PRINTING CO., ST. LOUIS.
- STYLE 2  
R. P. STUDLEY & CO., PRINTERS, ST. LOUIS
- STYLE 3  
THE MAYNARD-GOUGH CO., PRINTERS, WORCESTER.
- STYLE 4  
TRIBUNE JOB PRINTING CO.

- STYLE 5  
WOODWARD & TIERNAN PRINTING CO.
- STYLE 6  
BANNER PTG. CO.
- STYLE 7  
LITTLE & BECKER, PRINT.
- STYLE 8  
NIXON-JONES.

\* If Imprints are wanted longer than 1¼ inches in length, they will have to be made in two or more pieces, and \$3.00 per hundred will be charged for each extra piece.

**INTELLIGENCER PRINT, WHEELING.**

GILLIES, "THE" PRINTER, ROCHESTER, N. Y.      [COPYRIGHTED]      C. E. NORTHROP, PRINTER, BUFFALO, N. Y.  
 COPYRIGHT, 1897, BY KEPPLER & SCHWARZMANN      PRESS OF STYLES & CASH, NEW YORK.  
**WM. P. BENNETT, PRINT. PITTSBURGH.**  
 ROGERS & SHERWOOD, NEW YORK.      STYLES & CASH, N. Y.      PRESS OF STYLES & CASH, N. Y.  
**ALBERT B. KING, 89 WILLIAM ST., N. Y.**  
 PUSEY & TROXELL, PRINTERS AND STATIONERS 1398 BROADWAY, N. Y.      THOMSON & CO., PRINTERS, 55 DEY ST., N. Y.

**THE EICHBAUM PRESS, PITTSBURGH.**

**NEW METAL BRACES**

15

6 POINT

EACH \$0 05

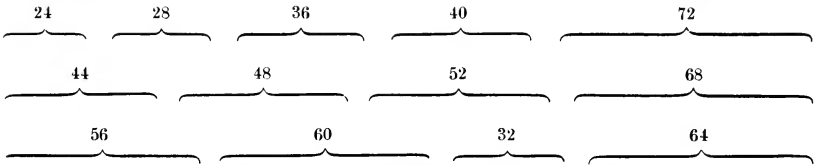

*Cast in any length from 24 Point to 72 Point*

**Six Point Braces and Dashes No. 2**

12

PER FONT

\$1 25

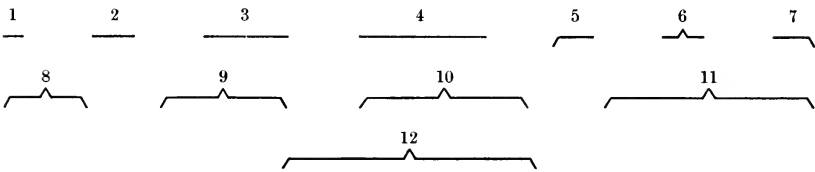

*Nos. 8 to 12 are complete. Nos. 1 to 7 are for piecing*

**Six Point Metal Braces**

12

PER FONT

\$1 00

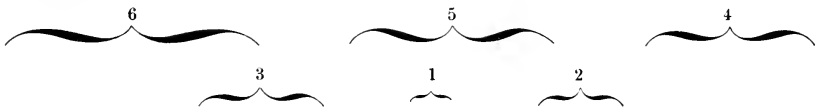

**Pin, Nail and Screw Heads**

15

PER FONT

\$0 75

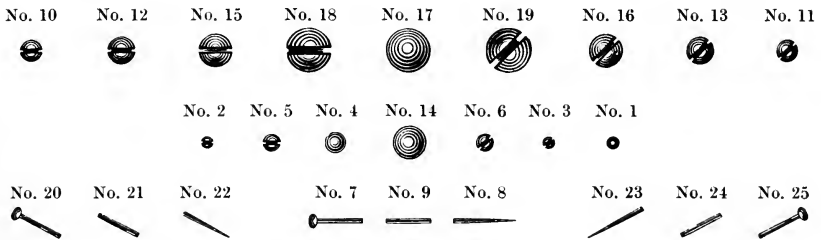

*Fonts contain twelve of each character*

Perpetual Logotype Calendars

1896 JUNE 1896							3	APRIL
Su	Mo	Tu	We	Th	Fr	Sa		
	1	2						
7	8	9						
14	15	16						
21	22	23						

1896 JANUARY 1896						
SUN	MON	TUE	WED	THU	FRI	SAT
			1	2	3	4
5	6	7	8	9	10	11
12	13	14	15	16	17	18

No. 3—\$3.00 per set, including fifty-two Logotypes, Rules, and Fonts for Month and Year; can be used for any month in any year. Change can be made in three minutes. Dimensions, 3 5-16 x 2 3/8 inches

No. 2—\$3.50 per set, including fifty-two Logotypes, Rules, and Fonts for Month and Year; can be used for any month in any year. Dimensions, 3 3/8 x 3 3/8 inches

Perpetual Logotype Calendars

2

1896 AUGUST 1896							26		58	
SUN	MON	TUE	WED	THU	FRI	SAT				
2	3	4	5	6	7	8				
9	10	11								
16	17	18								
							31	5972		

1896 JANUARY 1896						
Su	Mo	Tu	We	Th	Fr	Sa
			1	2	3	4

No. 1—\$4 00 per set, including fifty-two Logotypes, Rules, and Fonts for Month and Year; can be used for any month in any year. Change can be made in three minutes. Dimensions, 4 $\frac{3}{8}$  x 3 $\frac{3}{4}$  inches

No. 4—\$2 50 per set, including fifty-two Logotypes, Rules, and Fonts for Month and Year; can be used for any month in any year. Change can be made in three minutes. Dimensions, 2 $\frac{5}{8}$  x 2 $\frac{3}{4}$  inches

Sectional Logotype Calendars

## DECEMBER, 189

Sun	Mon	Tue	Wed	Thu
--	--	1	2	3
6	7	8	9	10
13	14	15	16	17
20	21	22	23	24
27				

SECTIONAL CALENDAR NO. 6—\$3 00  
Dimensions, 3½ x 3¾. Rules and Figures for One  
Month, with Changes for Ten Years

## AUGUST, 1896.

Sun	Mon	Tue	Wed	Thu	Fri	Sat
						1
2	3	4	5	6	7	8
9	10	11	12	13	14	15
16	17	18	19	20	21	22
23	24	25	26	27	28	29
30	31					

SECTIONAL CALENDAR NO. 5—\$2 50  
Rules and Figures for One Month, with Changes  
for Ten Years



**Sectional Logotype Calendars**

**JULY, 1896**

Sun	Mon	Tue	Wed	Thu	Fri	Sat
-----	-----	-----	-----	-----	-----	-----

			1	2	3	4
5	6	7	8	9	10	11
12	13	14	15	16	17	18
19	20	21	22	23	24	25
26	27	28	29	30	31	

SECTIONAL CALENDAR NO. 8—\$4.00

Rules and Figures for One Month, with Changes for Ten Years

**POINTERS**

12

PER FONT \$1 25

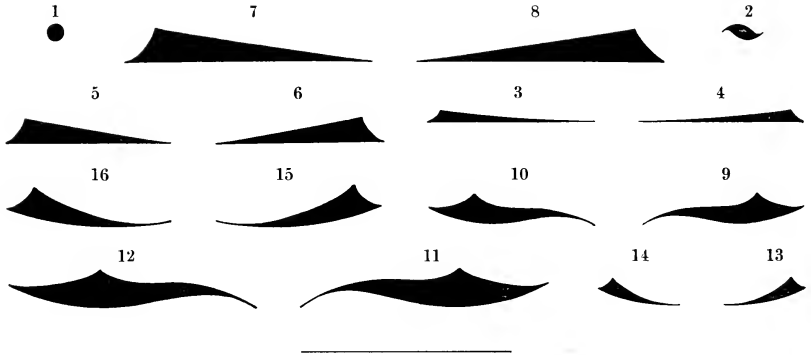

**CONTOUR POINTERS**

12

PER FONT \$1 25

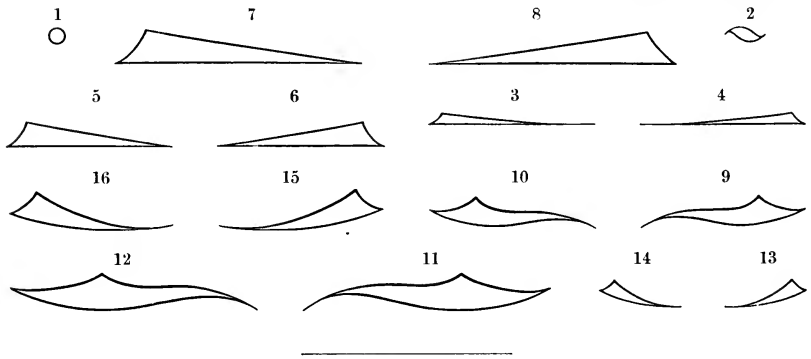

**SHADED POINTERS**

12

PER FONT \$1 25

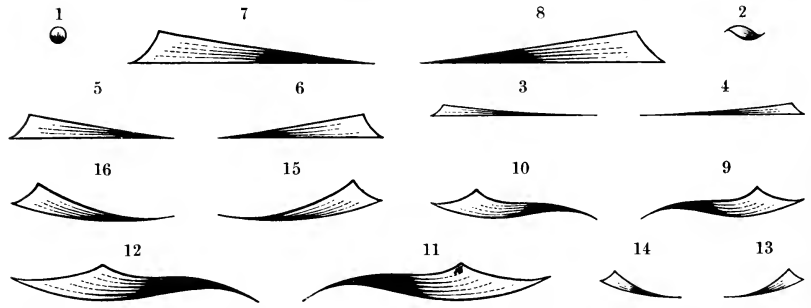

*Pointers are cast on 6 and 12 Point bodies. Nos. 3, 4, 5, 6, 7 and 8 of the three series are made to line with 2 Point Rule No. 203E*

**PALMETTO ORNAMENTS**

12

PER FONT \$1 00

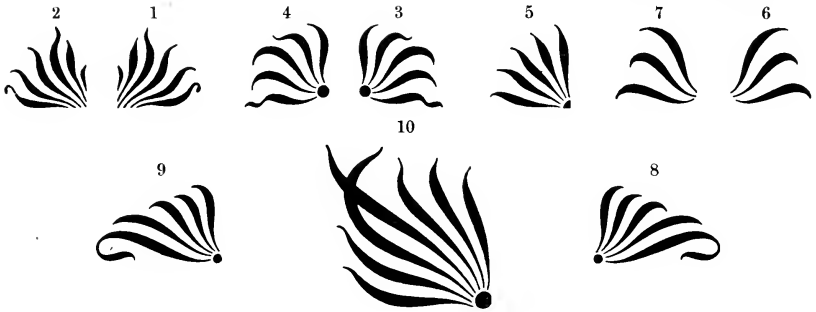

**CONTOUR PALMETTO ORNAMENTS**

12

PER FONT \$1 00

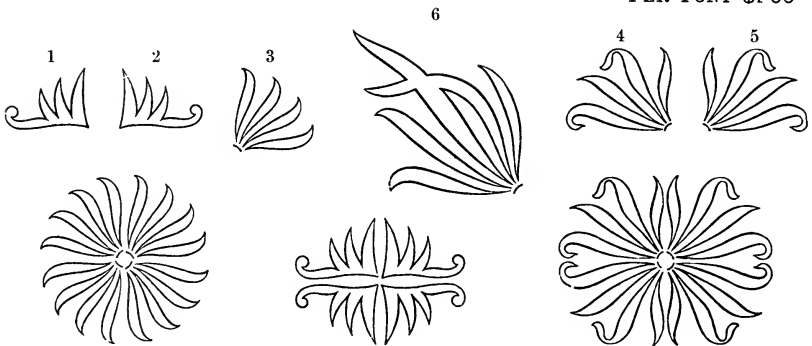

**SHADED PALMETTO ORNAMENTS**

12

PER FONT \$1 00

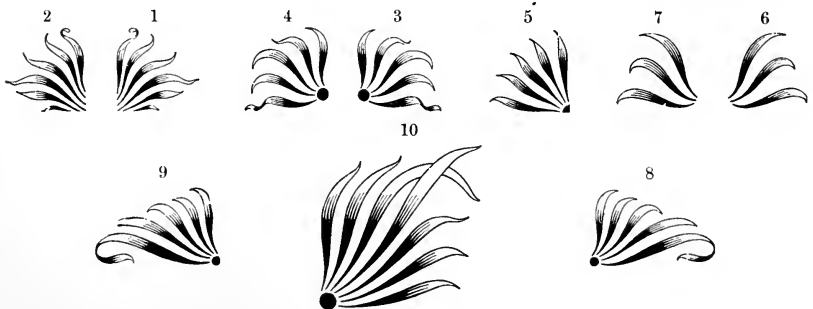

**TWINKLERS**

12

Cast on 6, 12, 18, 24  
and 36 Point bodies

PER FONT \$1 00

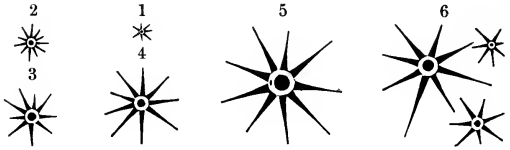

**TWINKLER BORDERS**

12

6 POINT NO. 155 10 FEET \$2 60

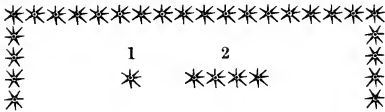

12 POINT NO. 157 5 FEET \$1 75

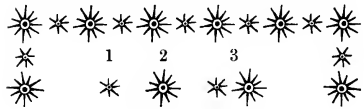

12 POINT NO. 156 5 FEET \$1 75

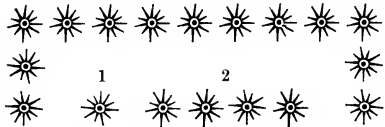

18 POINT NO. 158 4 FEET \$3 10

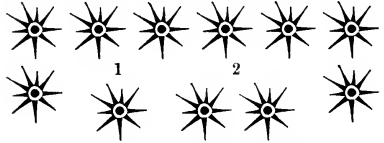

18 POINT NO. 159

4 FEET \$3 10

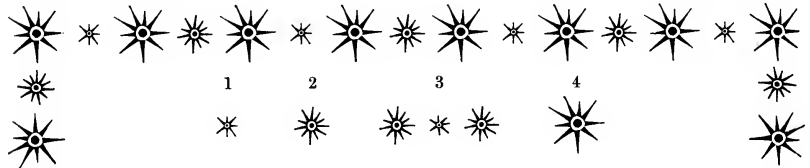

18 POINT NO. 160

4 FEET \$3 10

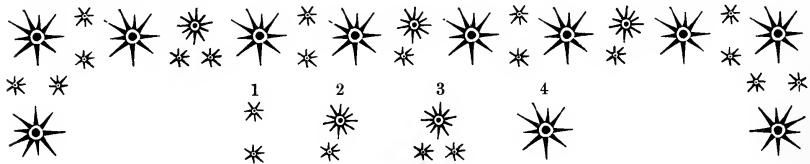

**PRINTERS' NIC NACS**

12

All on 6 Point body

PER FONT \$1 00

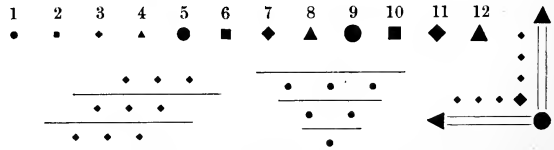

RULE ORNAMENTS

—12—

SERIES NO. 1

PER FONT \$1 10

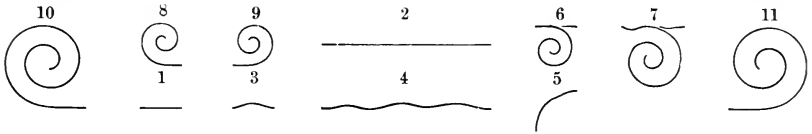

SERIES NO. 2

PER FONT \$1 10

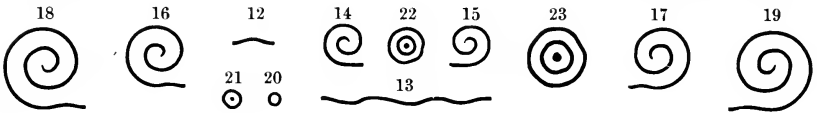

SERIES NO. 3

PER FONT \$1 25

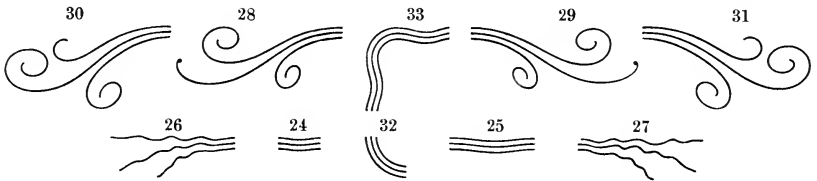

SERIES NO. 4

PER FONT \$1 00

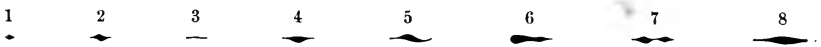

CENTRAL ORNAMENTS

—15—

SERIES NO. 1

PER FONT \$1 00

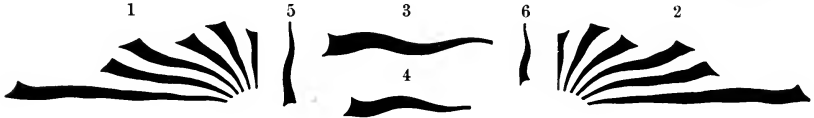

SERIES NO. 2

PER FONT \$1 00

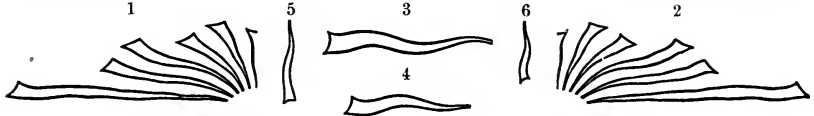

SERIES NO. 3

PER FONT \$1 00

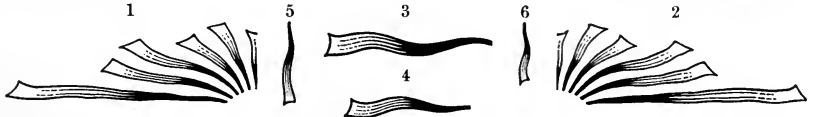

**CENTRAL ORNAMENTS No. 4**

15

PER FONT

\$2 00

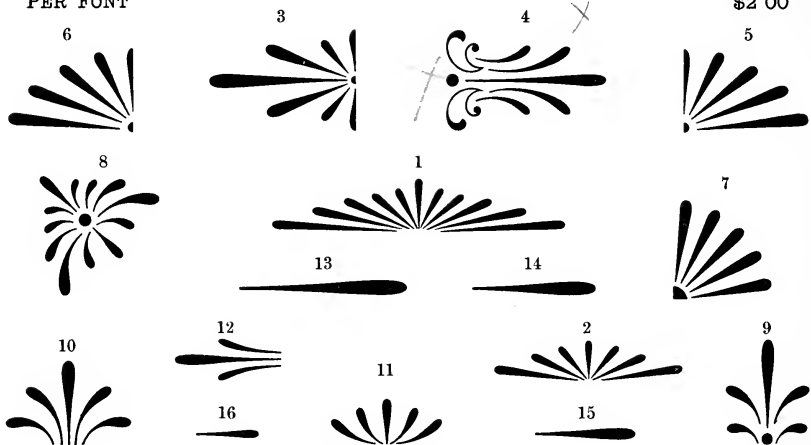

**CENTRAL ORNAMENTS No. 5**

15

PER FONT

\$2 00

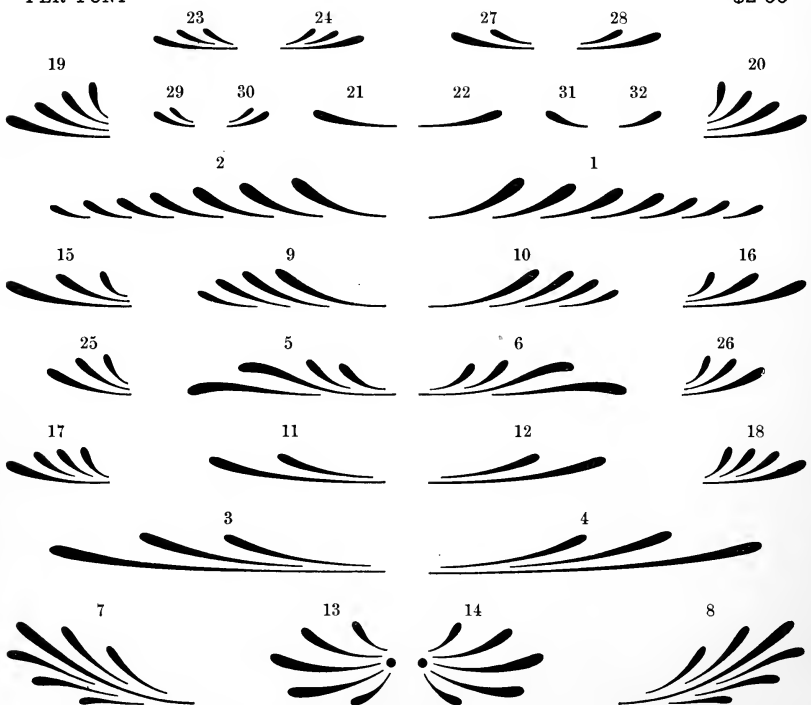

**CENTRAL ORNAMENTS No. 6**

15

PER FONT

\$2 00

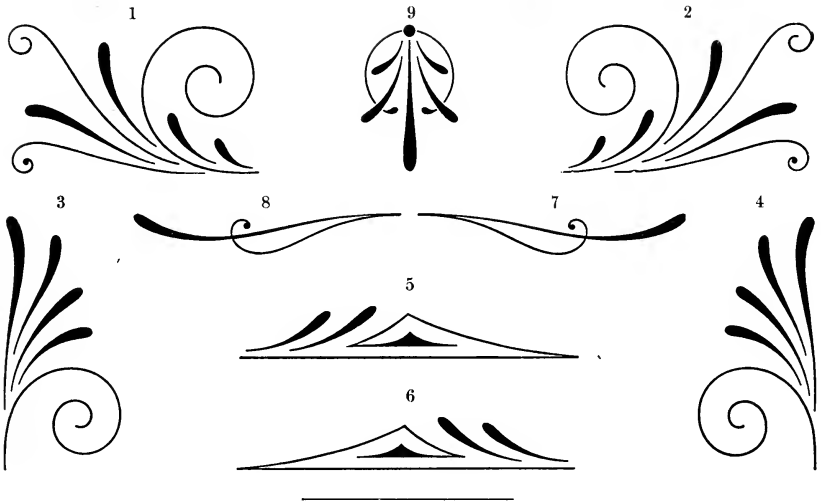

**TURNER ORNAMENTS**

12

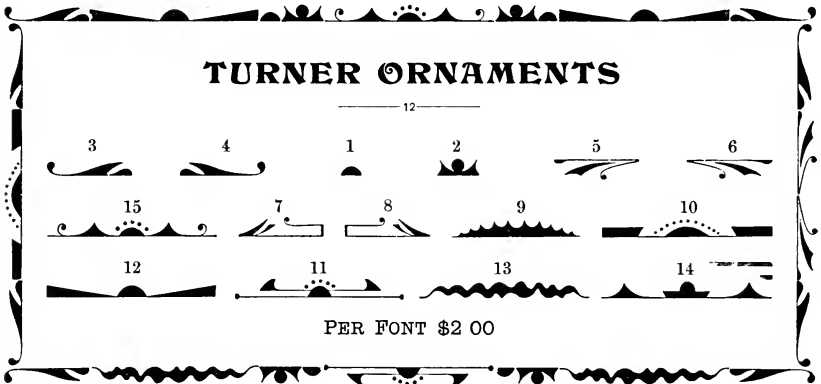

PER FONT \$2 00

**STELLAR ORNAMENTS**

15

PER FONT

\$1 25

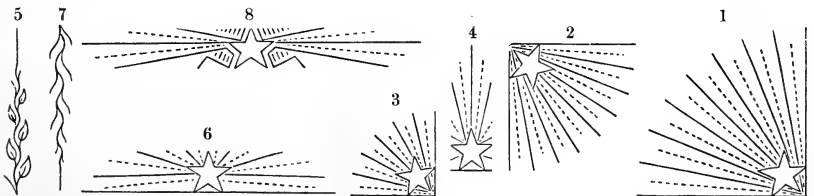

*All characters on multiples of 6 Point*

**Auxiliaries Series 2**

12

WHOLE FONT \$4 50  
HALF FONT . . 2 50

**CHARACTERS**

19

662



WHOLE FONT  
\$4 80

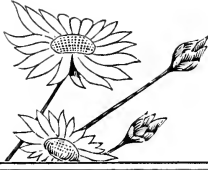

**Auxiliaries Series 3** <sup>12</sup>



HALF FONT  
\$2 75

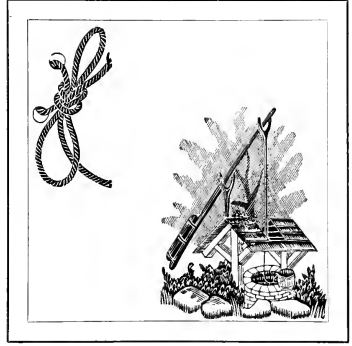

**CHARACTERS**

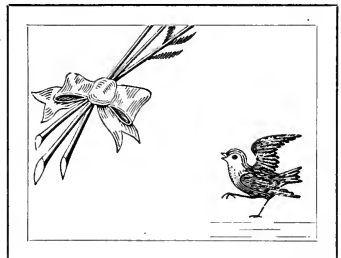
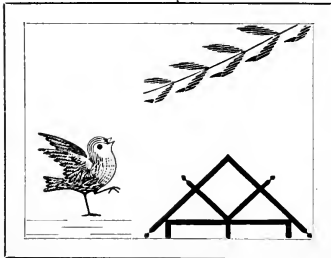
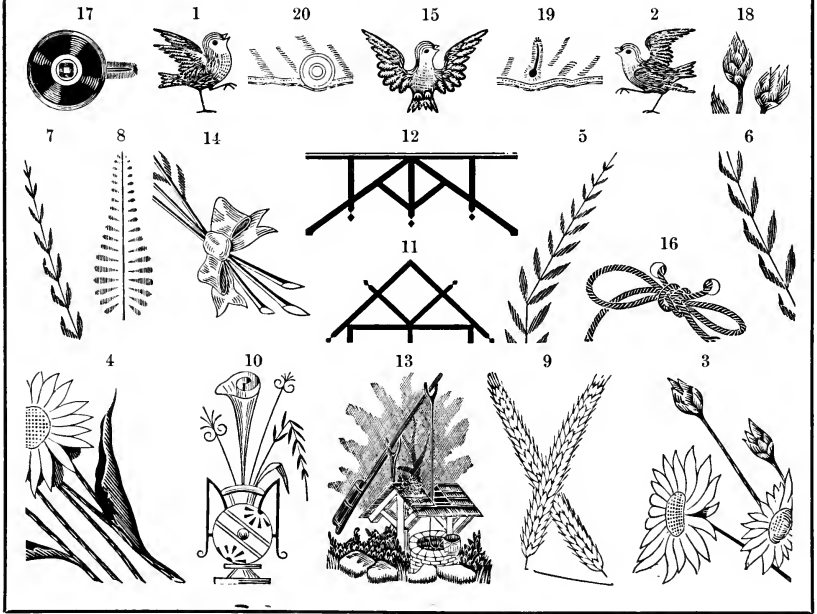

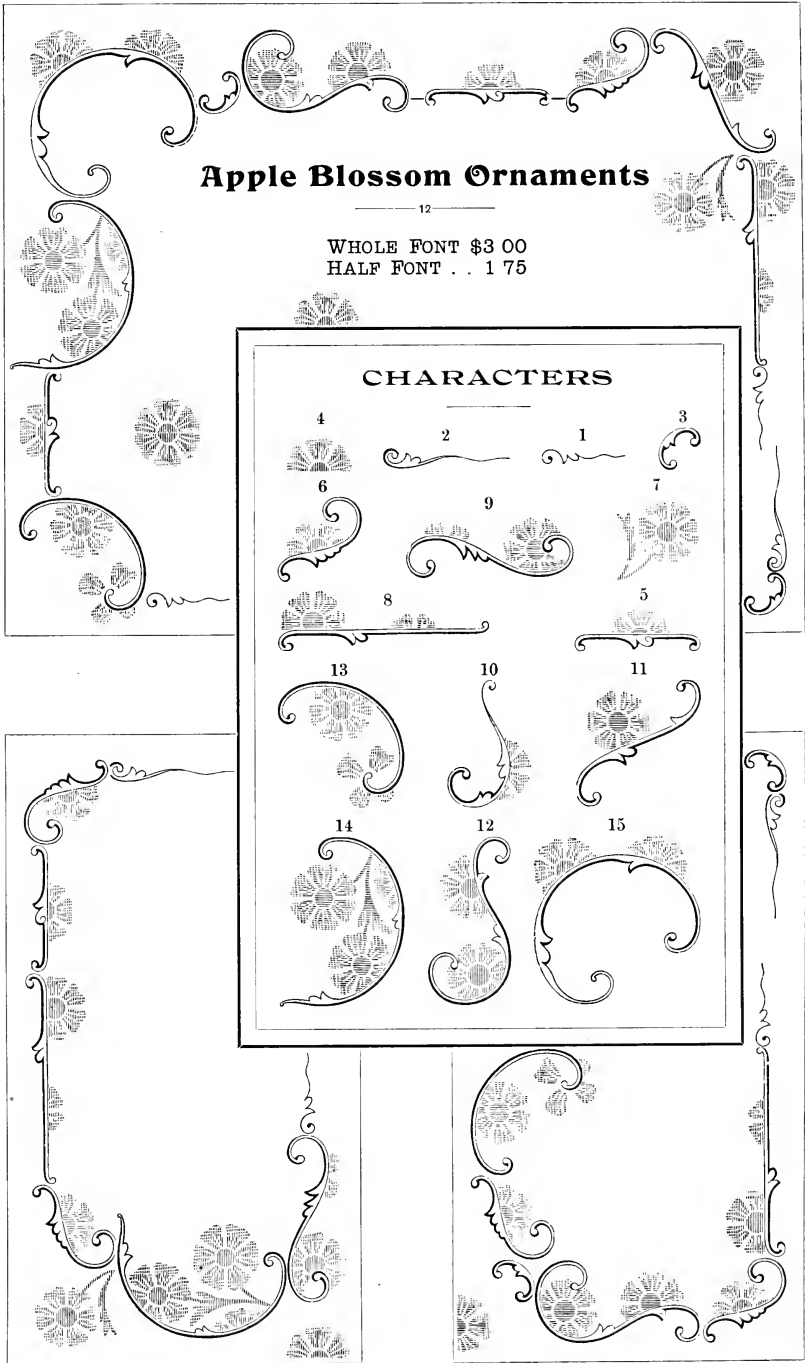

COPPER ALLOY TYPE



**Margin Ornaments**  
**Series 1**

15

PER FONT \$1 25



**Scroll Corner Ornaments**

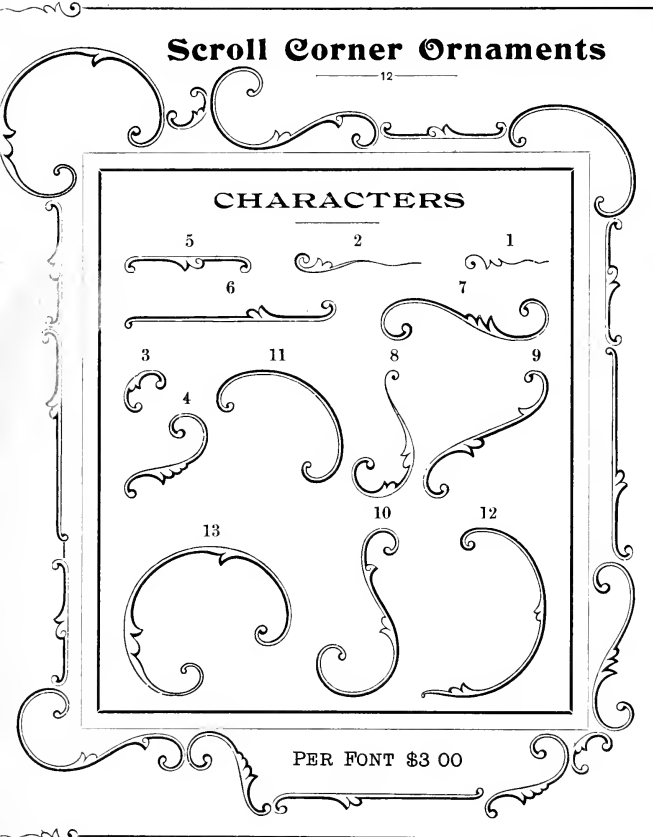

**CHARACTERS**

5 2 1

6 7

3 11 8 9

4

10 12

13

PER FONT \$3 00



**Margin Ornaments**  
**Series 2**

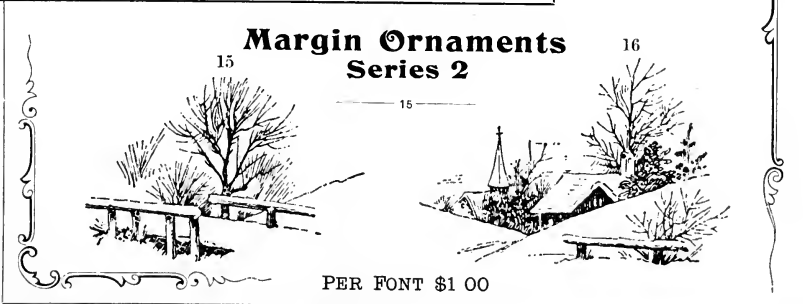

15



16



PER FONT \$1 00

HAPPY THOUGHTS

Group K

Each character put up in sets of four at 50 cents per set

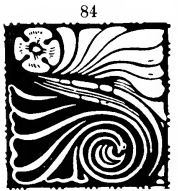
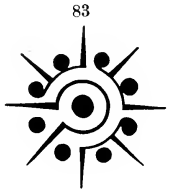
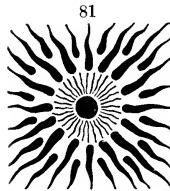
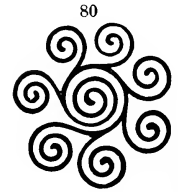
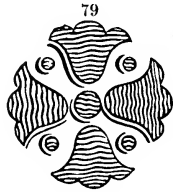
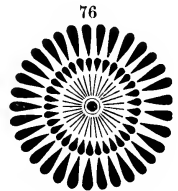
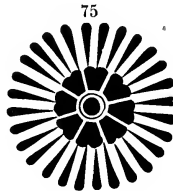
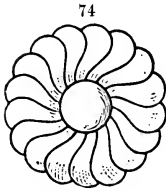
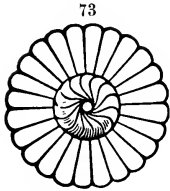

Group H

Each character put up in sets of four at 50 cents per set



Group L

Each character put up in sets of four at 50 cents per set

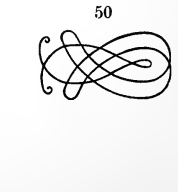
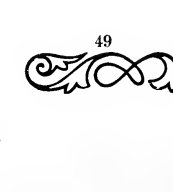
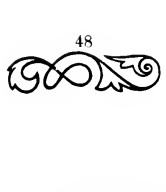
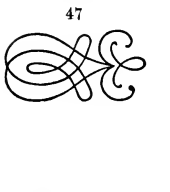

**ROCCO BORDER**

15

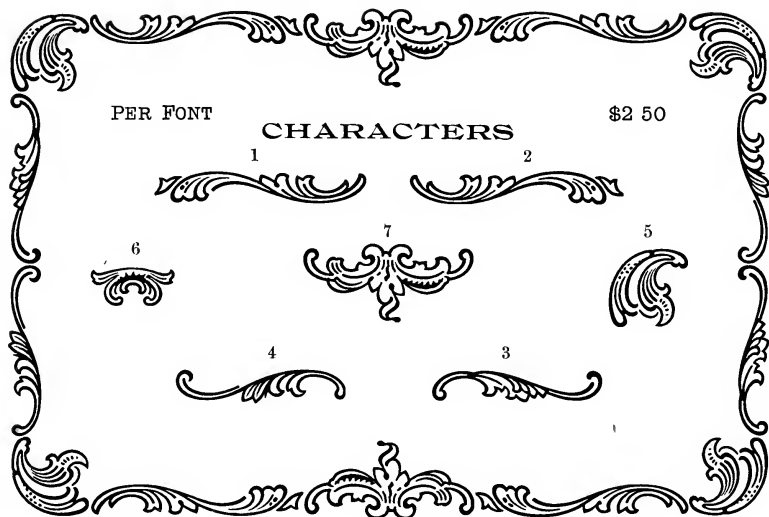

**Combination Ornaments**

**Series M**

15

PER FONT \$3 00

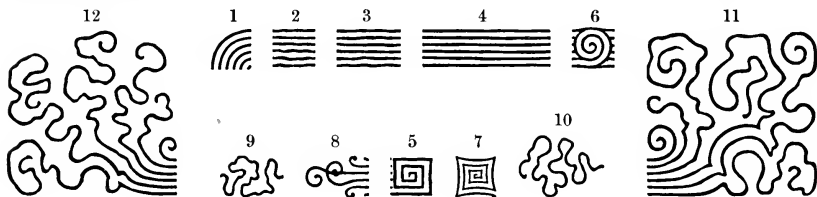

**Word Ornaments**

**Series N**

15

PER FONT \$2 00

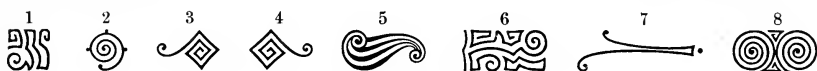

**Word Ornaments**

15

**Series O**

PER FONT \$1 25



**Combination Ornaments**

15

**Series P**

PER FONT \$1 25

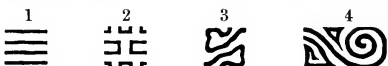

Cast on 12, 18, 24 and 48 Point bodies

**CAXTON BORDERS**

18 POINT No. 240



30 INCHES \$1 50



12 POINT No. 239



36 INCHES \$1 50



10 POINT No. 238



40 INCHES \$1 50



6 POINT No. 237



54 INCHES \$1 50



6 POINT No. 236

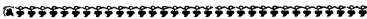

54 INCHES \$1 50

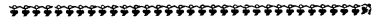

**ELZEVIR BORDERS AND BANDS**

6 POINT No. 100



54 INCHES \$1 50

14 POINT No. 104



36 INCHES \$1 50

14 POINT No. 106



24 INCHES \$1 50

20 POINT No. 108



30 INCHES \$1 50

20 POINT No. 109



30 INCHES \$1 50

ELZEVIR FLORETS

Group A

COMPLETE FONT \$1 50

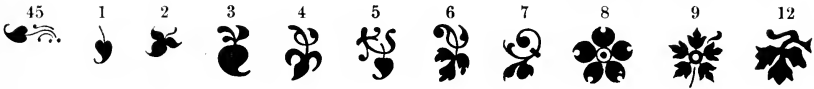

Group B

FOUR OF ONE CHARACTER 40 CTS.

COMPLETE FONT \$2 00

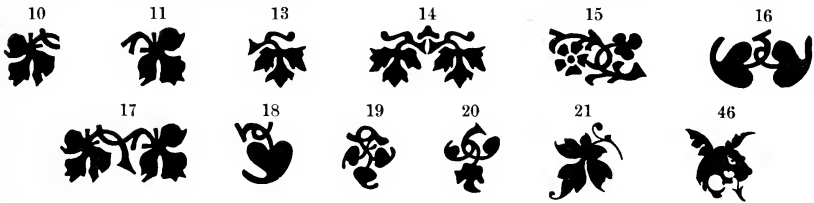

Group C

FOUR OF ONE CHARACTER 48 CTS.

COMPLETE FONT \$2 00

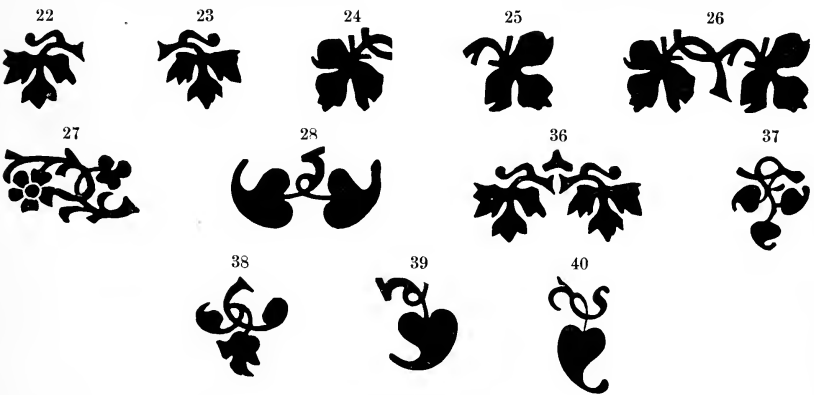

Group D

FOUR OF ONE CHARACTER 48 CTS.

COMPLETE FONT \$2 00

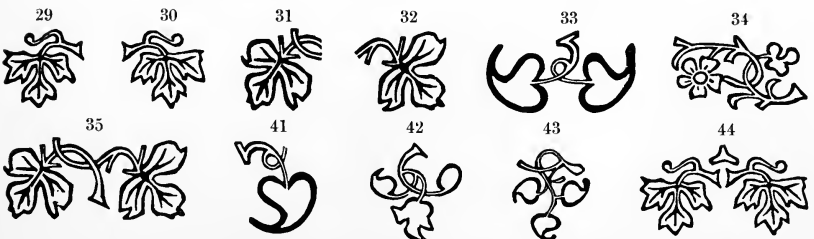

*Florets of Groups C and D are made for printing over each other in different colors*

**COLLINS FLORETS**

**Group N**

FOUR OF ONE CHARACTER 40 CENTS PER FONT \$3 00

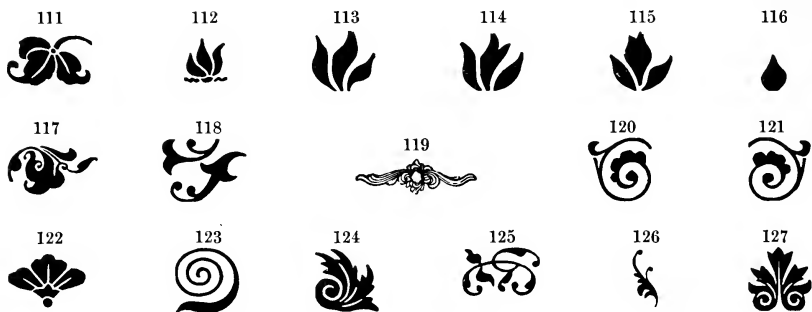

**Group Q**

FOUR OF ONE CHARACTER 40 CENTS

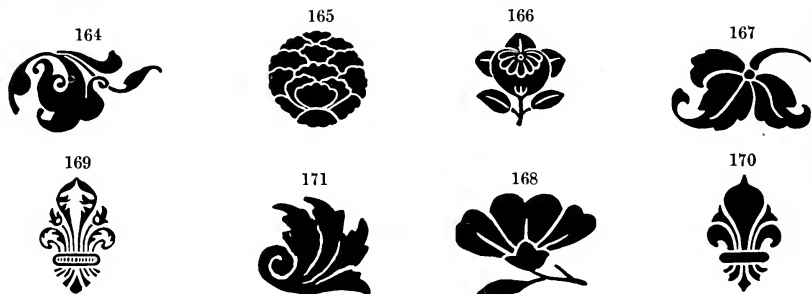

**Group R**

FOUR OF ONE CHARACTER 50 CENTS

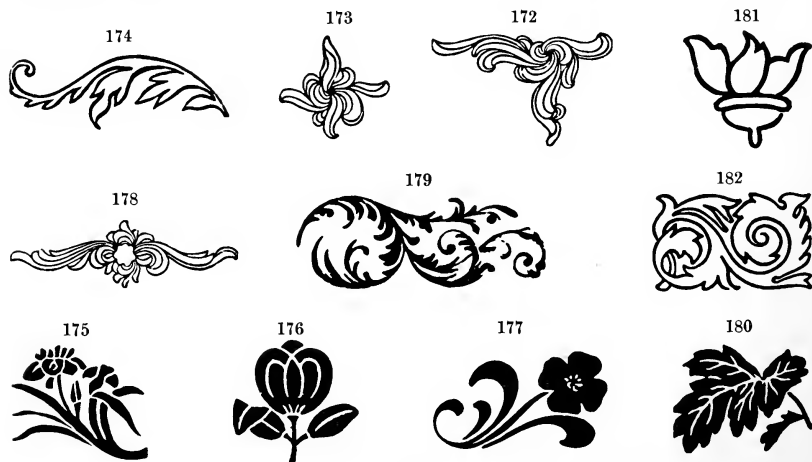



**COLLINS FLORETS—Single Characters**

185. 30 cts.



202. 30 cts.



183. 30 cts.



204. 30 cts.



186. 30 cts.



194. 40 cts.



193. 40 cts.

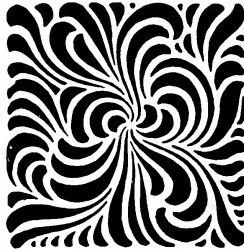

195. 40 cts.



184. 30 cts.



192. 30 cts.

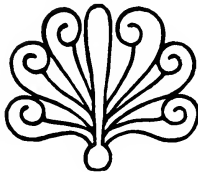

187. 30 cts.

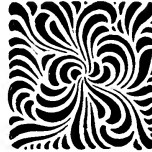

205. 30 cts.



215. 15 cts.



191. 30 cts.



188. 30 cts.



190. 30 cts.



201. 40 cts.

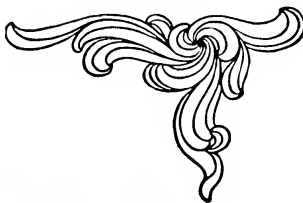

196. 40 cts.

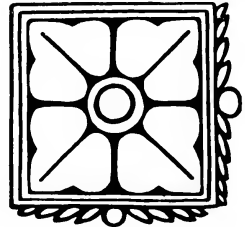

**COLLINS BANDS**

12 POINT NO. 202

36 INCHES \$1 50



12 POINT NO. 174

36 INCHES \$1 50



12 POINT NO. 175

36 INCHES \$1 50



12 POINT NO. 176

36 INCHES \$1 50



18 POINT NO. 182

30 INCHES \$1 50



18 POINT NO. 183

30 INCHES \$1 50



18 POINT NO. 184

30 INCHES \$1 50



18 POINT NO. 181

30 INCHES \$1 50



18 POINT NO. 177

30 INCHES \$1 50



18 POINT NO. 178

30 INCHES \$1 50



**COLLINS BANDS**

18 POINT NO. 179

30 INCHES \$1 50



18 POINT NO. 180

30 INCHES \$1 50



24 POINT NO. 185

20 INCHES \$1 50



24 POINT NO. 188

20 INCHES \$1 50



24 POINT NO. 189

20 INCHES \$1 50



30 POINT NO. 192

20 INCHES \$1 50



42 POINT NO. 194

12 INCHES \$1 50



42 POINT NO. 193

12 INCHES \$1 50



**COLLINS BANDS**

18 POINT No. 216

30 INCHES \$1 50



24 POINT No. 209

20 INCHES \$1 50



18 POINT No. 220

30 INCHES \$1 50



18 POINT No. 214

30 INCHES \$1 50



18 POINT No. 218

30 INCHES \$1 50



18 POINT No. 212

30 INCHES \$1 50



24 POINT No. 206

20 INCHES \$1 50



24 POINT No. 207

20 INCHES \$1 50



30 POINT No. 191

20 INCHES \$1 50



**COLLINS BORDERS**

18 POINT NO. 198

30 INCHES \$1 50



18 POINT NO. 173

30 INCHES \$1 50



24 POINT NO. 196

20 INCHES \$1 50

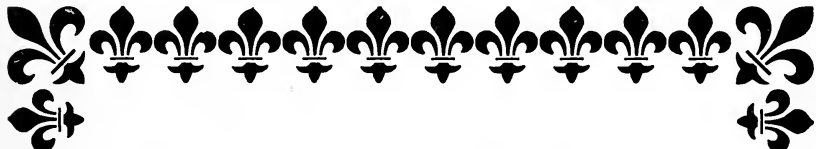

24 POINT NO. 195

20 INCHES \$1 50



36 POINT NO. 172

18 INCHES \$1 50



18 POINT NO. 223

30 INCHES \$1 50



30 POINT NO. 203

20 INCHES \$1 50



FLORENTINE BORDERS

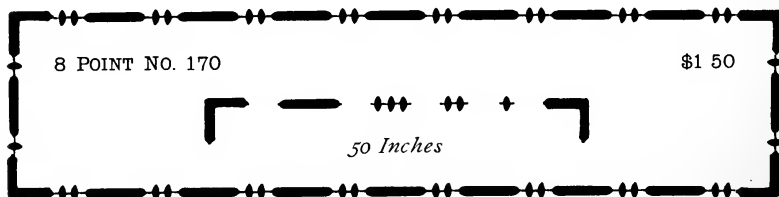
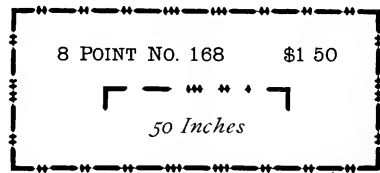
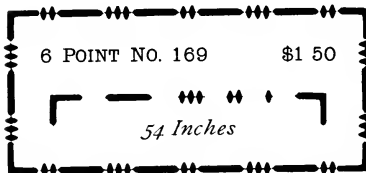
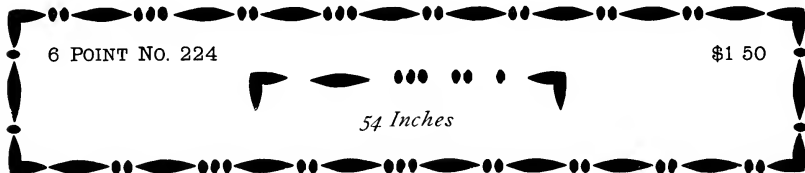
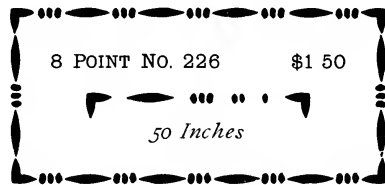
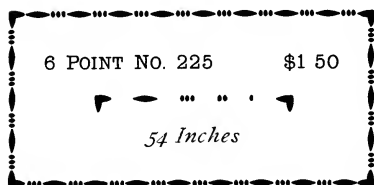
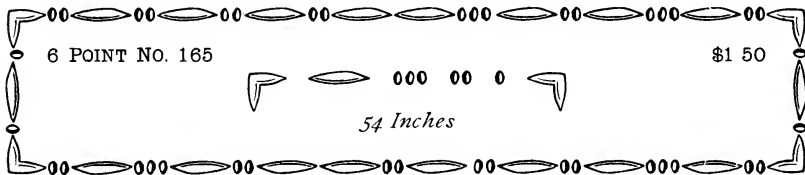
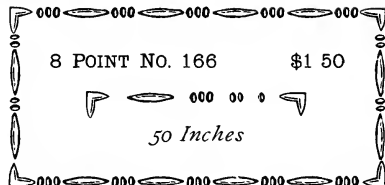
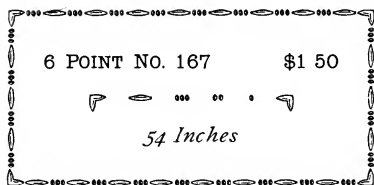

FLORENTINE BORDERS

8 POINT NO. 227

\$1 50

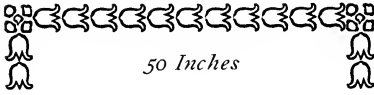

50 Inches

8 POINT NO. 161

\$1 50

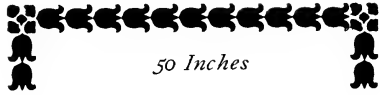

50 Inches

8 POINT NO. 152

\$1 50

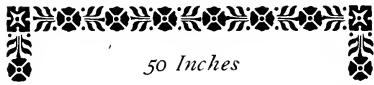

50 Inches

8 POINT NO. 156

\$1 50



50 Inches

12 POINT NO. 155

\$1 50



36 Inches

12 POINT NO. 149

\$1 50



36 Inches

12 POINT NO. 164

\$1 50



36 Inches

12 POINT NO. 151

\$1 50



36 Inches

16 POINT NO. 150

\$1 50



30 Inches

16 POINT NO. 154

\$1 50



30 Inches

24 POINT NO. 162

\$1 50



20 Inches

18 POINT NO. 163

\$1 50



30 Inches

EMPIRE BORDERS

15



36 POINT NO. 1 \$2 50

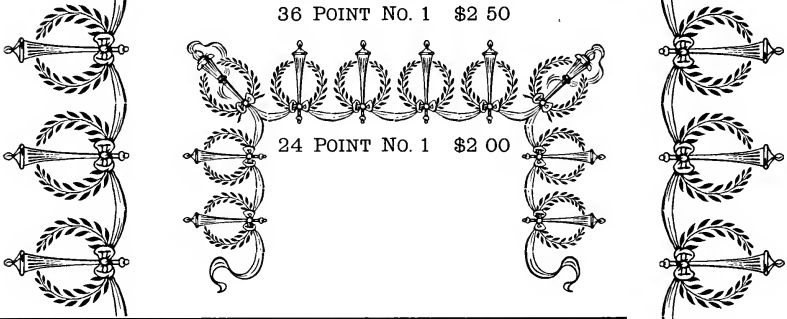

24 POINT NO. 1 \$2 00

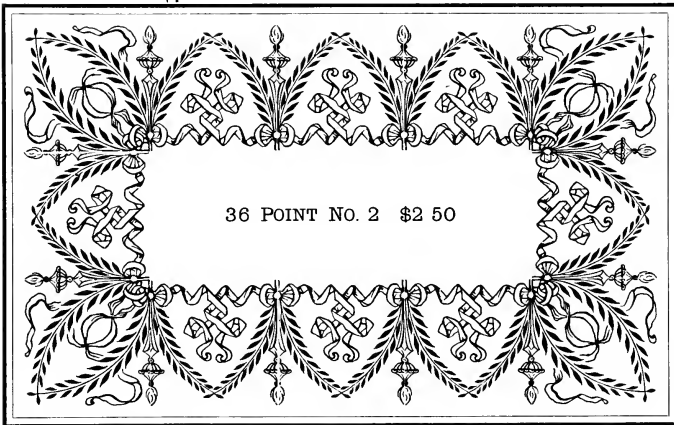

36 POINT NO. 2 \$2 50

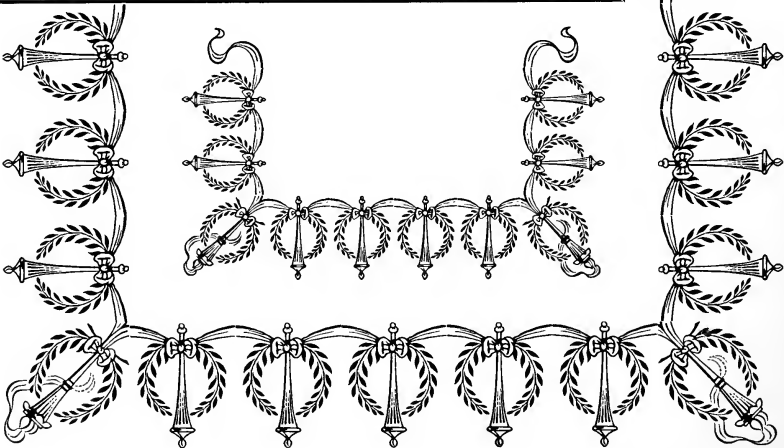



EMPIRE BORDERS

15

36 POINT NO. 3 \$2 50



24 POINT NO. 3 \$2 00

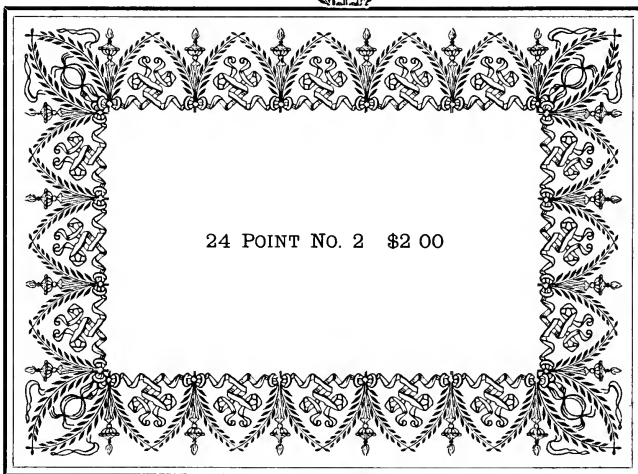
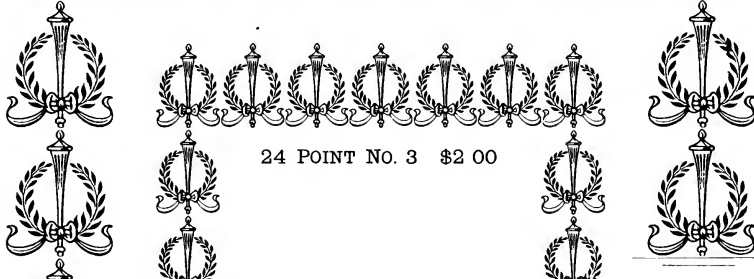

24 POINT NO. 2 \$2 00

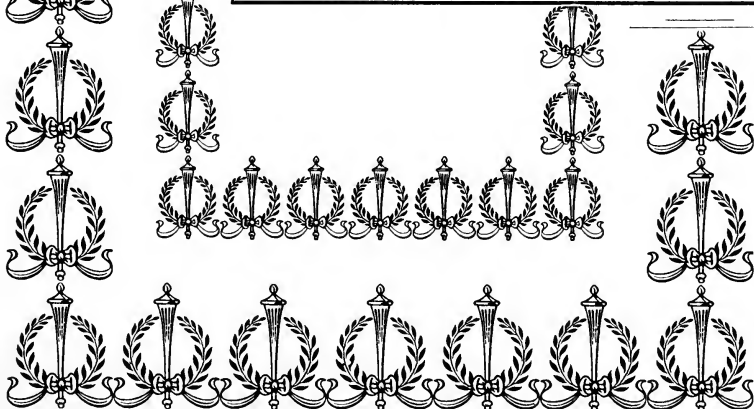

LAUREL BORDERS

6

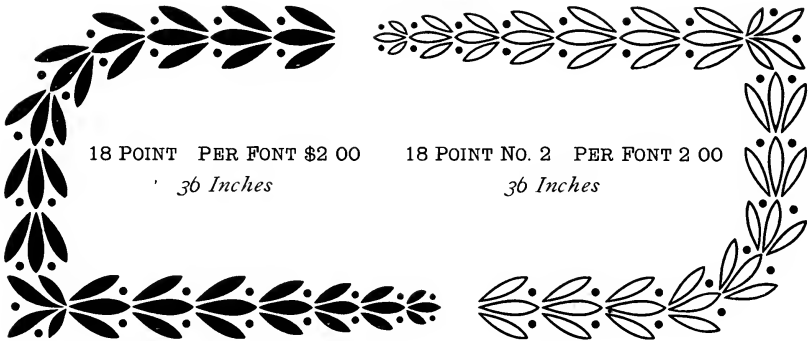

18 POINT PER FONT \$2 00  
*36 Inches*

18 POINT NO. 2 PER FONT 2 00  
*36 Inches*

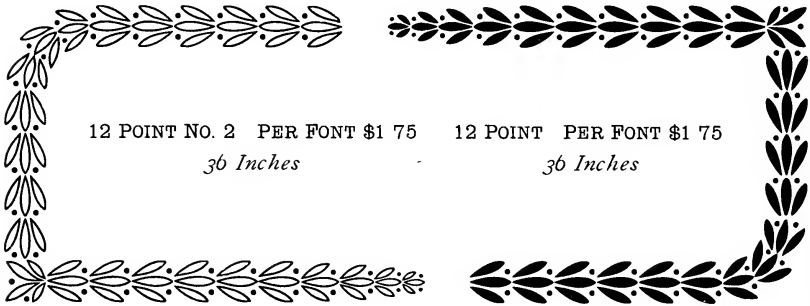

12 POINT NO. 2 PER FONT \$1 75  
*36 Inches*

12 POINT PER FONT \$1 75  
*36 Inches*

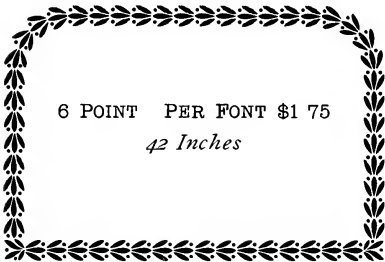

6 POINT PER FONT \$1 75  
*42 Inches*

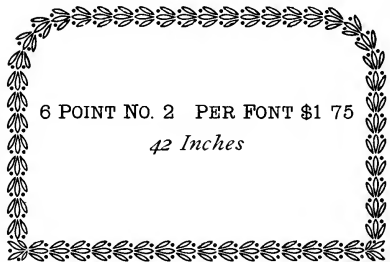

6 POINT NO. 2 PER FONT \$1 75  
*42 Inches*

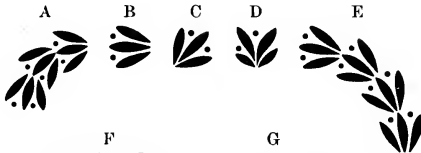

*All sizes contain the above pieces*

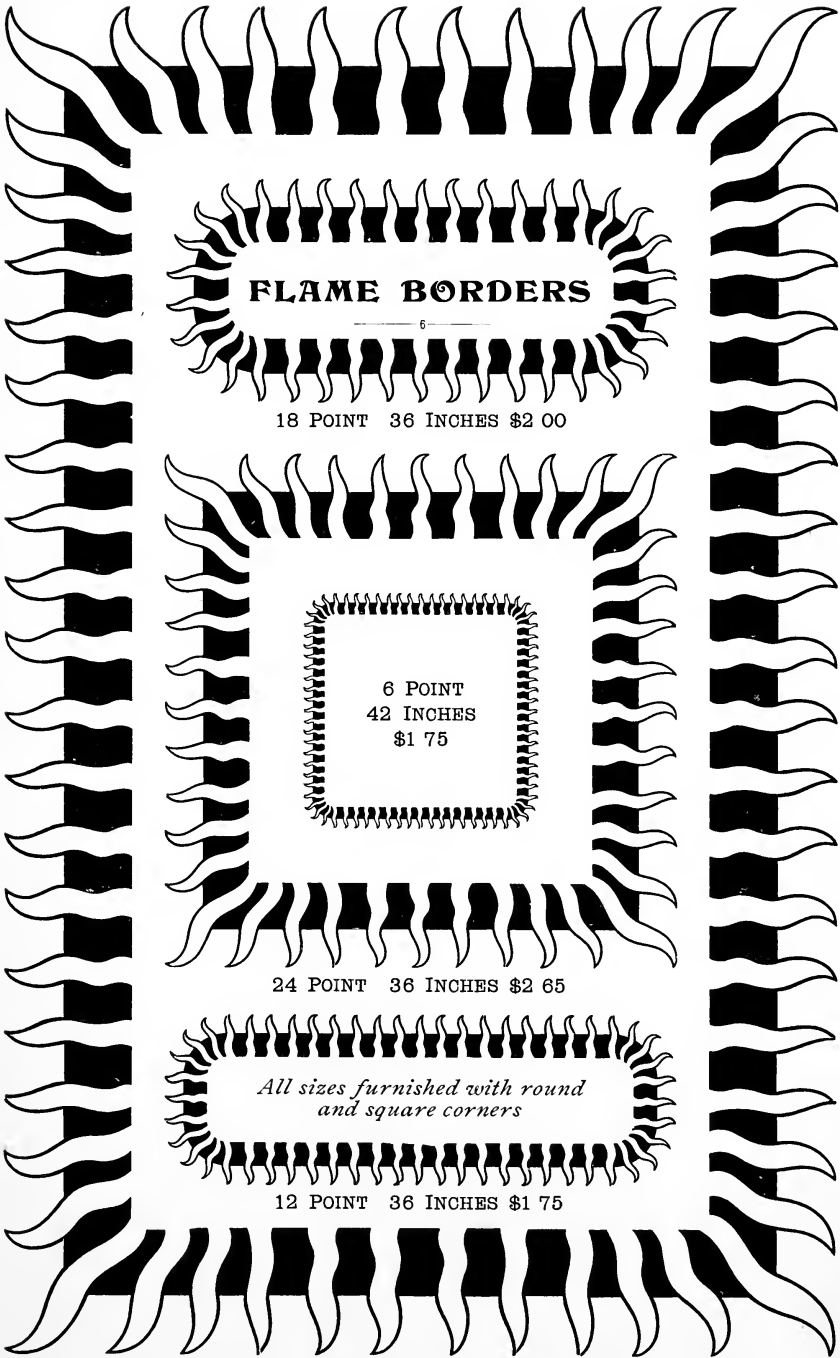

**FLAME BORDERS**

6

18 POINT 36 INCHES \$2 00

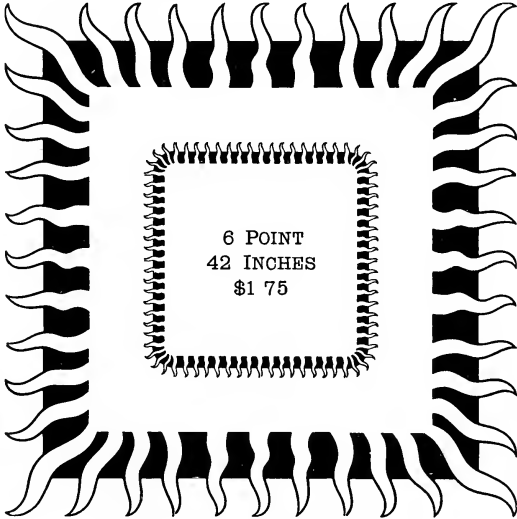

6 POINT  
42 INCHES  
\$1 75

24 POINT 36 INCHES \$2 65

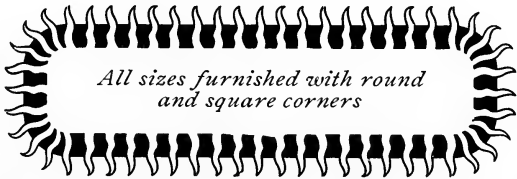

*All sizes furnished with round  
and square corners*

12 POINT 36 INCHES \$1 75

36 POINT 50 INCHES \$4 50

## POLKA-DOT BORDERS

—12—

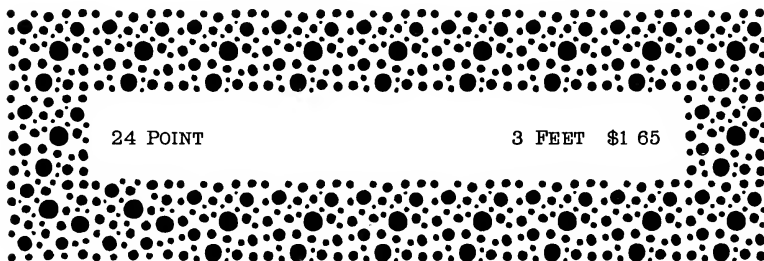

—12—

## RUSTIC BAND BORDER

24 POINT

3 FEET \$1 65



**POINTER BORDERS**

12

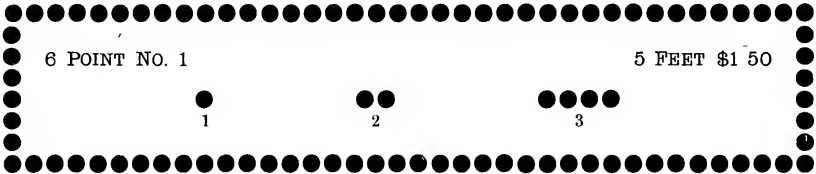
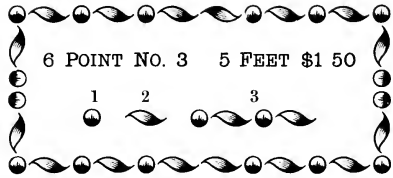
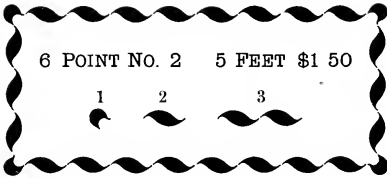

**DARLING BORDERS**

12

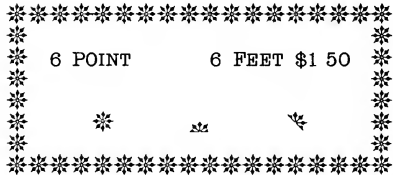

**DAISY BORDERS**

12

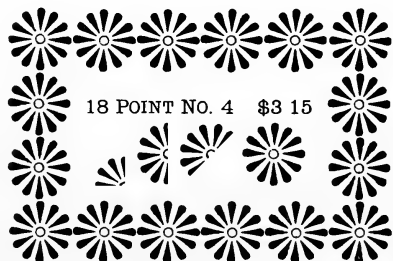
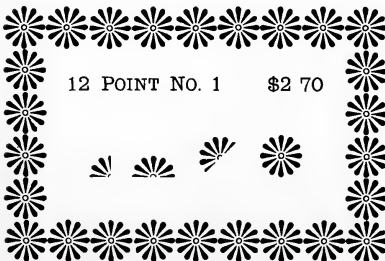
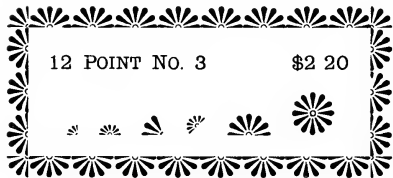
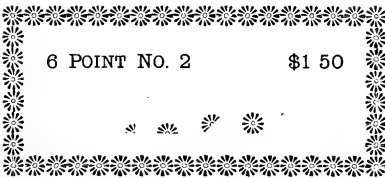

ART BORDERS

15



12 POINT NO. 3 TINT \$1 60  
60 Inches

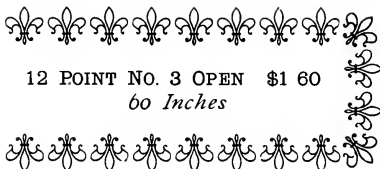

12 POINT NO. 3 OPEN \$1 60  
60 Inches

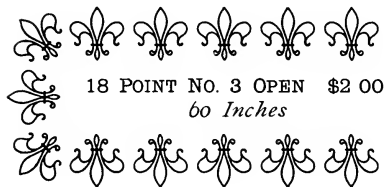

18 POINT NO. 3 OPEN \$2 00  
60 Inches



18 POINT NO. 3 TINT \$2 00  
60 Inches



24 POINT NO. 3 TINT \$1 65  
36 Inches



24 POINT NO. 3 OPEN \$1 65  
36 Inches

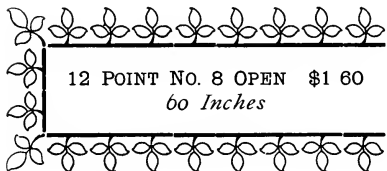

12 POINT NO. 8 OPEN \$1 60  
60 Inches

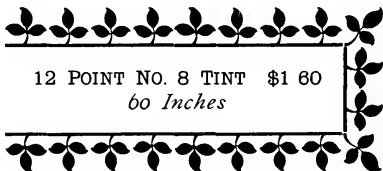

12 POINT NO. 8 TINT \$1 60  
60 Inches

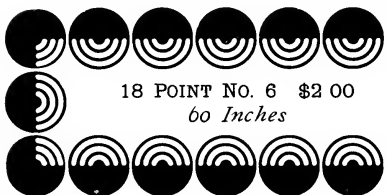

18 POINT NO. 6 \$2 00  
60 Inches

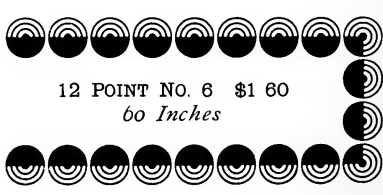

12 POINT NO. 6 \$1 60  
60 Inches

*These Borders are made to register for two colors*

ART BORDERS

15

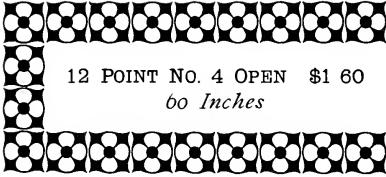

12 POINT NO. 4 OPEN \$1 60  
*60 Inches*



12 POINT NO. 4 TINT \$1 60  
*60 Inches*

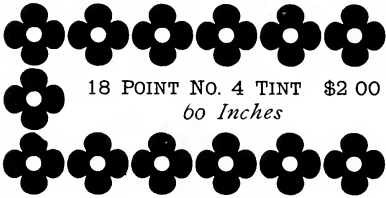

18 POINT NO. 4 TINT \$2 00  
*60 Inches*



18 POINT NO. 4 OPEN \$2 00  
*60 Inches*

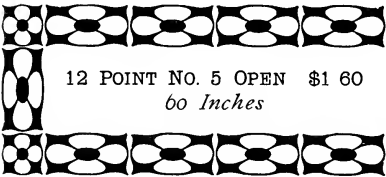

12 POINT NO. 5 OPEN \$1 60  
*60 Inches*

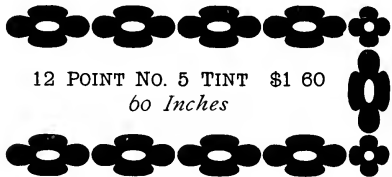

12 POINT NO. 5 TINT \$1 60  
*60 Inches*

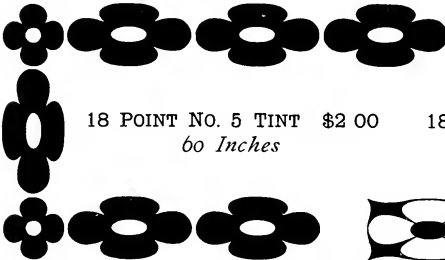

18 POINT NO. 5 TINT \$2 00  
*60 Inches*

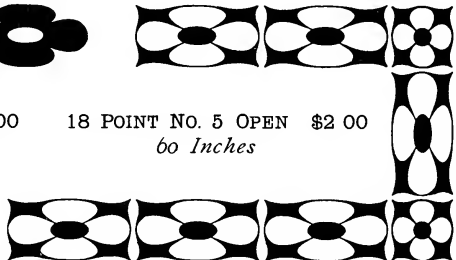

18 POINT NO. 5 OPEN \$2 00  
*60 Inches*

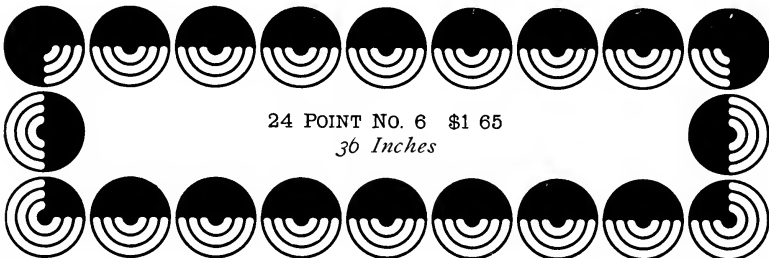

24 POINT NO. 6 \$1 65  
*36 Inches*

*These Borders are made to register for two colors*

ART BORDERS

15

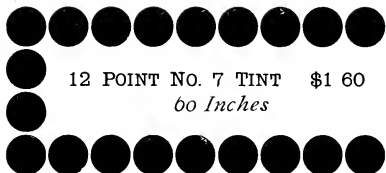

12 POINT NO. 7 TINT \$1 60  
60 Inches

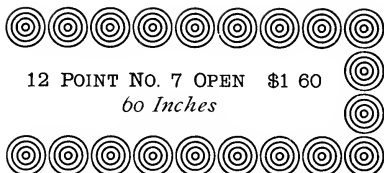

12 POINT NO. 7 OPEN \$1 60  
60 Inches

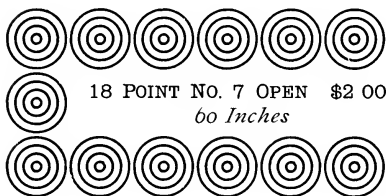

18 POINT NO. 7 OPEN \$2 00  
60 Inches

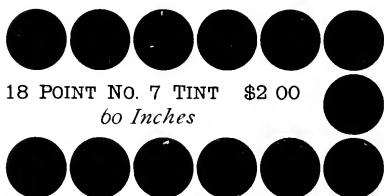

18 POINT NO. 7 TINT \$2 00  
60 Inches

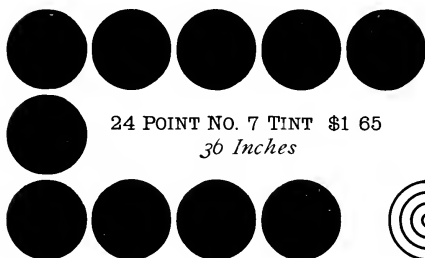

24 POINT NO. 7 TINT \$1 65  
36 Inches

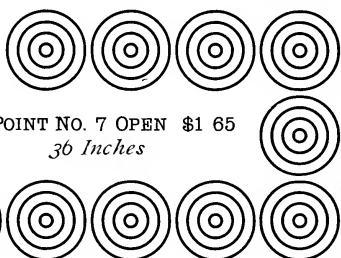

24 POINT NO. 7 OPEN \$1 65  
36 Inches

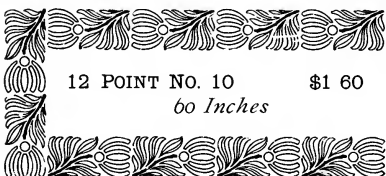

12 POINT NO. 10 \$1 60  
60 Inches

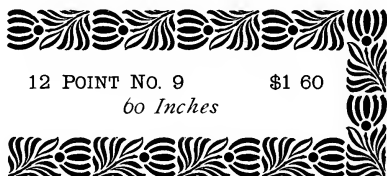

12 POINT NO. 9 \$1 60  
60 Inches



18 POINT NO. 9 \$2 00  
60 Inches

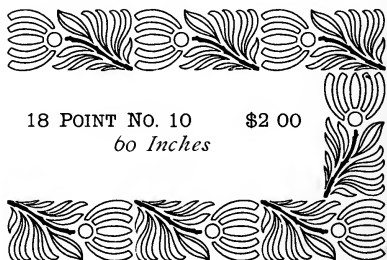

18 POINT NO. 10 \$2 00  
60 Inches

*These Borders are made to register for two colors*



ART BORDERS

15

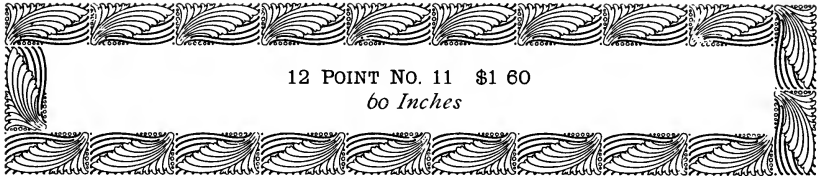

12 POINT NO. 11 \$1 60  
60 Inches

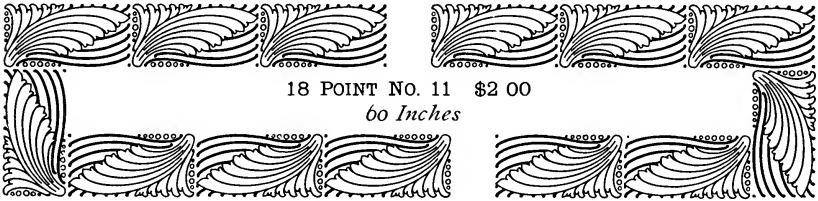

18 POINT NO. 11 \$2 00  
60 Inches

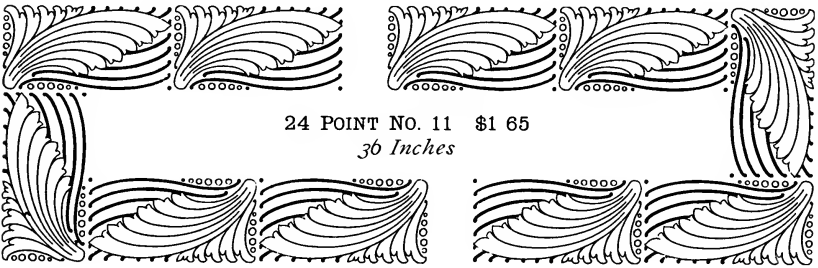

24 POINT NO. 11 \$1 65  
36 Inches

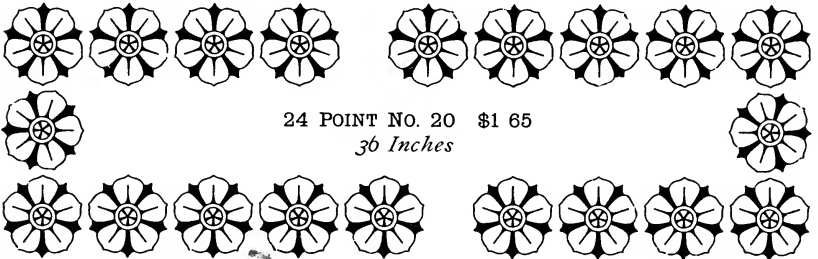

24 POINT NO. 20 \$1 65  
36 Inches



24 POINT NO. 9 \$1 65  
36 Inches

24 POINT NO. 10 \$1 65  
36 Inches

24 Point No. 9 and No. 10 will register for two colors

ART BORDERS

15



24 POINT NO. 24 \$1 65  
36 Inches

18 POINT NO. 22

\$2 00



60 Inches

24 POINT NO. 23

\$1 65



36 Inches

24 POINT NO. 15

\$1 65



36 Inches

24 POINT NO. 18

\$1 65



36 Inches

18 POINT NO. 18

\$2 00



60 Inches



36 POINT NO. 25 \$1 10  
12 Inches

**TWELVE POINT BORDERS**

PER FONT \$2 50

PER FOOT 40 CTS.

No. 1201

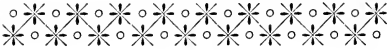

No. 1228

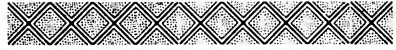

No. 1207



No. 1232



No. 1220



No. 1233



No. 1227



No. 1234



**EIGHTEEN POINT BORDERS**

PER FONT \$3 00

PER FOOT 50 CTS.

No. 1801



No. 1803



**TWENTY-FOUR POINT BORDERS**

PER FONT \$3 50

PER FOOT 60 CTS.

No. 2401



No. 2403



No. 2404



No. 2405



**Combination Border**

SERIES 98

FIRST SECTION

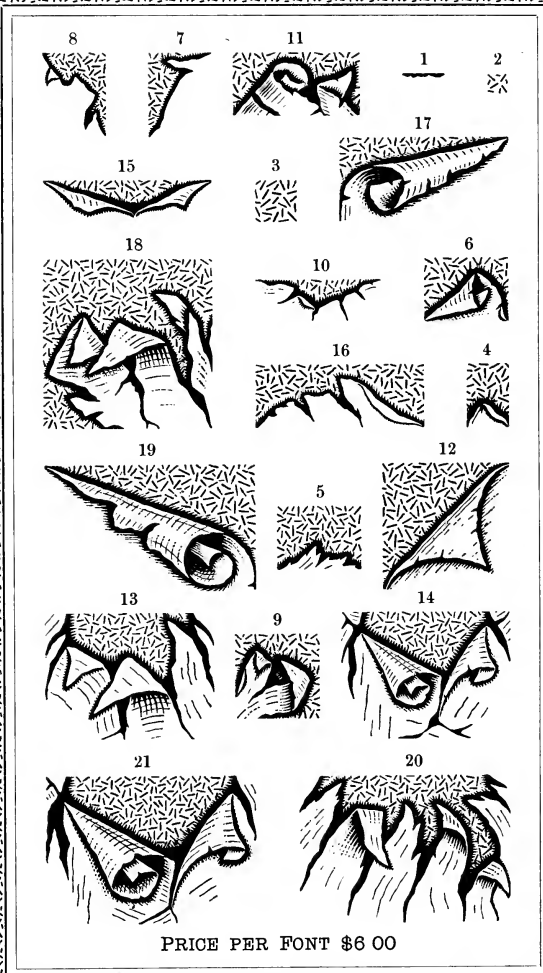

PRICE PER FONT \$6 00

**Combination Border**  
SERIES 98  
THIRD SECTION

17 decorative elements are shown, numbered 1 through 17. Element 1 is a simple horizontal line. Element 2 is a small square with horizontal lines. Element 3 is a square with a grid pattern. Element 4 is a vertical rectangle with horizontal lines and a decorative top edge. Element 5 is a triangle with a decorative top edge. Element 6 is a triangle with a decorative top edge. Element 7 is a horizontal rectangle with a decorative top edge. Element 8 is a square with a grid pattern and a decorative top edge. Element 9 is a horizontal rectangle with a decorative top edge. Element 10 is a horizontal rectangle with a decorative top edge. Element 11 is a triangle with a decorative top edge. Element 12 is a triangle with a decorative top edge. Element 13 is a triangle with a decorative top edge. Element 14 is a horizontal rectangle with a decorative top edge. Element 15 is a horizontal rectangle with a decorative top edge. Element 16 is a horizontal rectangle with a decorative top edge. Element 17 is a horizontal rectangle with a decorative top edge.

PRICE PER FONT \$5 00

**NEWSPAPER BORDERS**

—15—

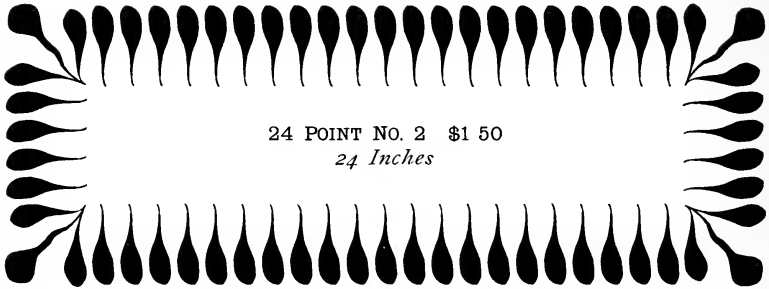

24 POINT NO. 2 \$1 50  
*24 Inches*

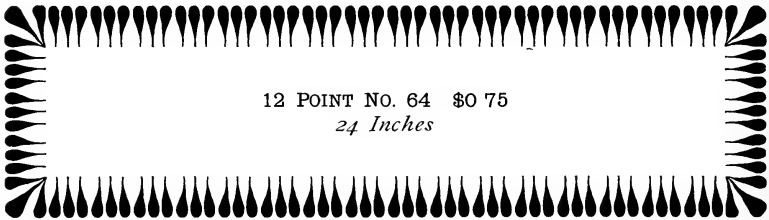

12 POINT NO. 64 \$0 75  
*24 Inches*

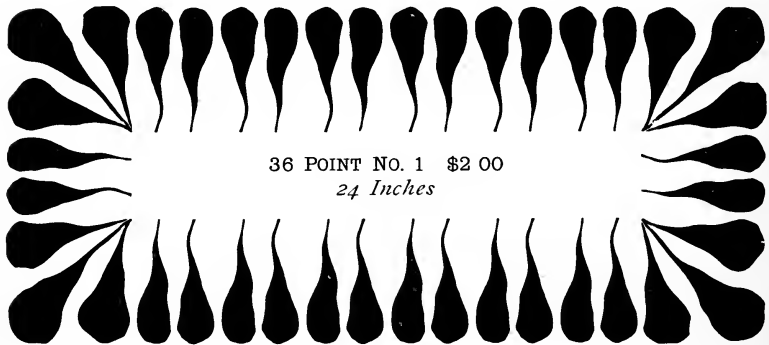

36 POINT NO. 1 \$2 00  
*24 Inches*



18 POINT NO. 18 \$1 00  
*24 Inches*

NEWSPAPER BORDERS

15

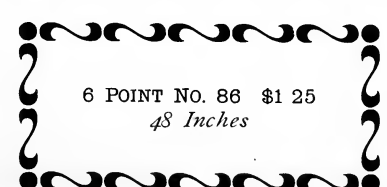
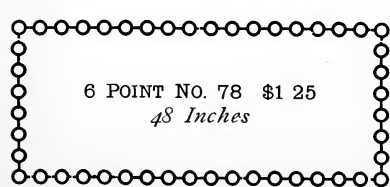
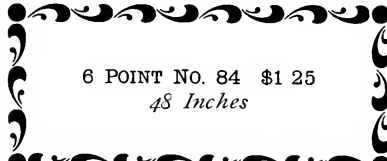
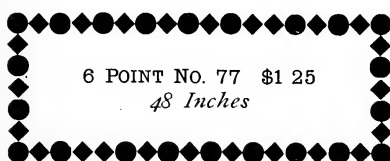
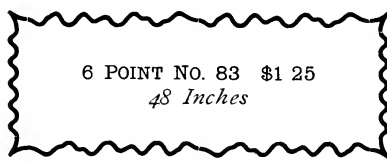
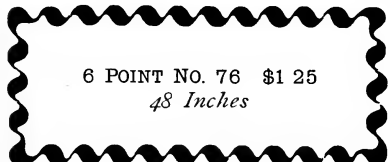
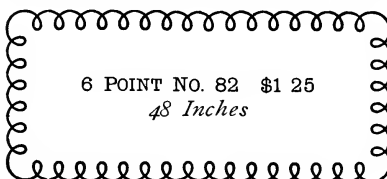
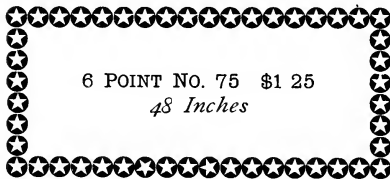
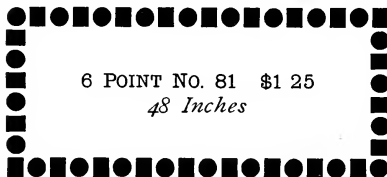
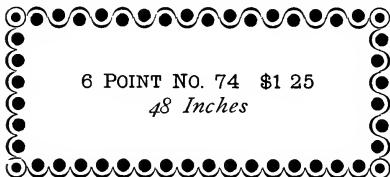
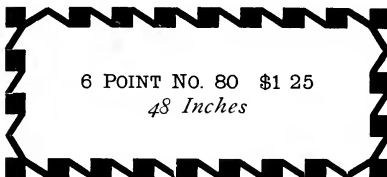
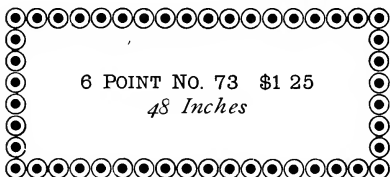
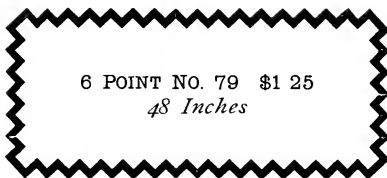
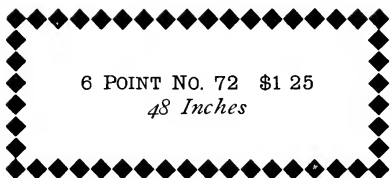

NEWSPAPER BORDERS

15

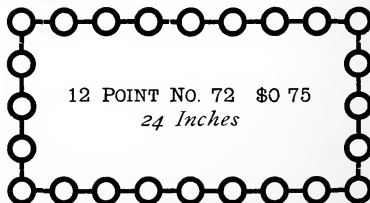
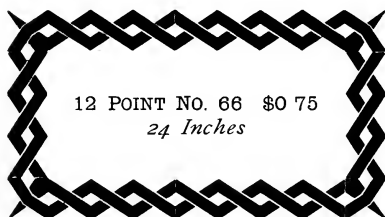
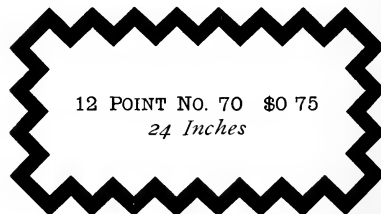
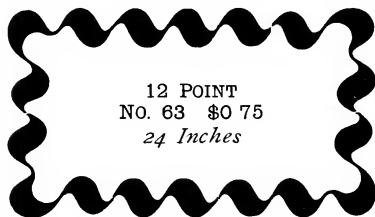
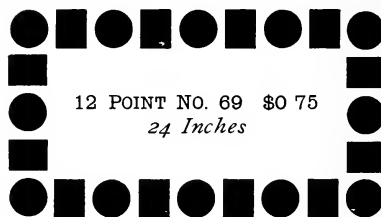
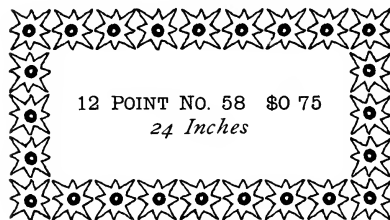
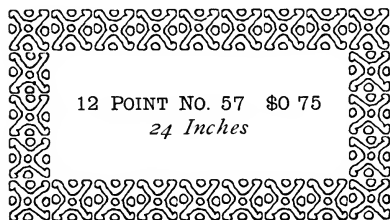
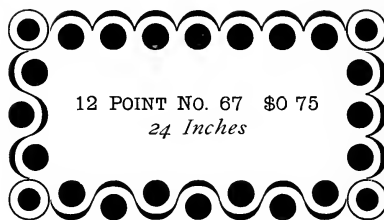
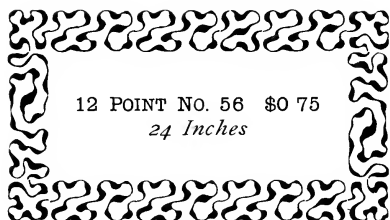



NEWSPAPER BORDERS

15

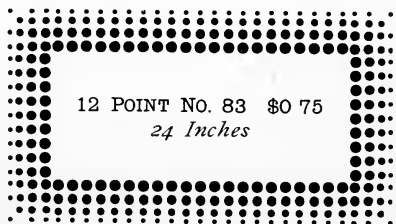
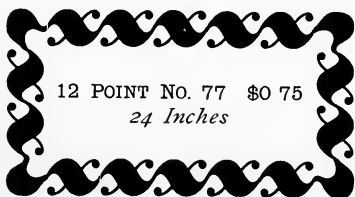
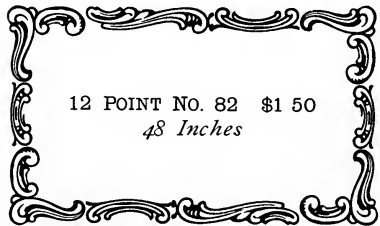
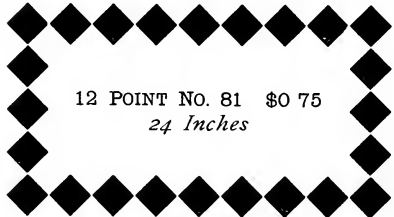
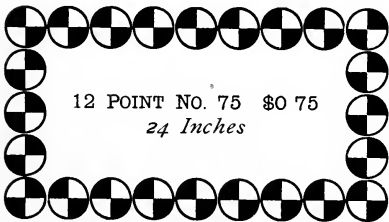
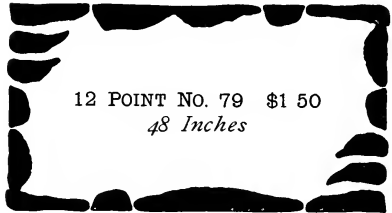
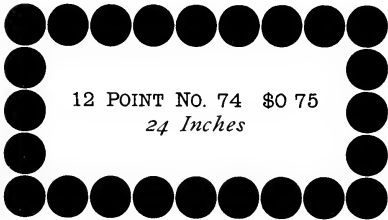
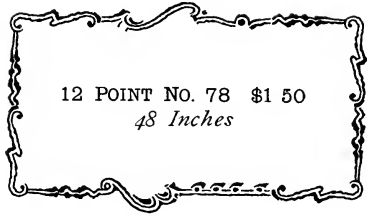
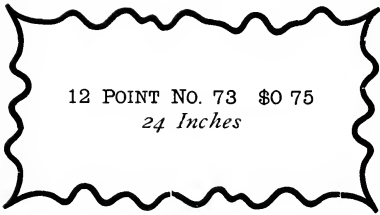

NEWSPAPER BORDERS

16

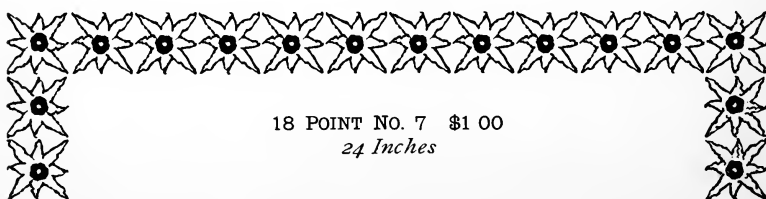
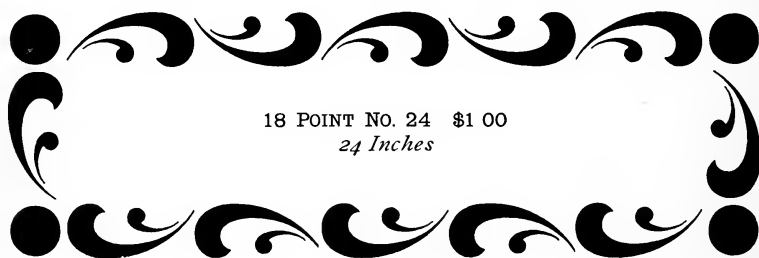
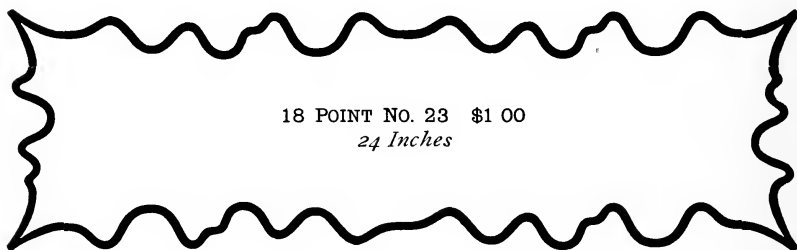
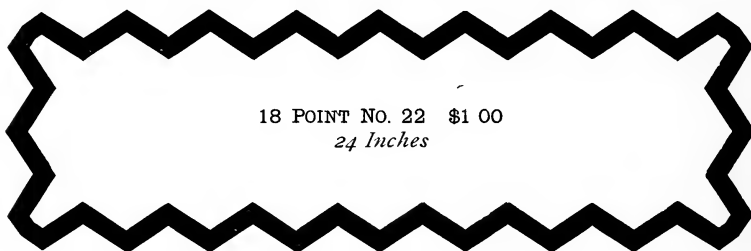
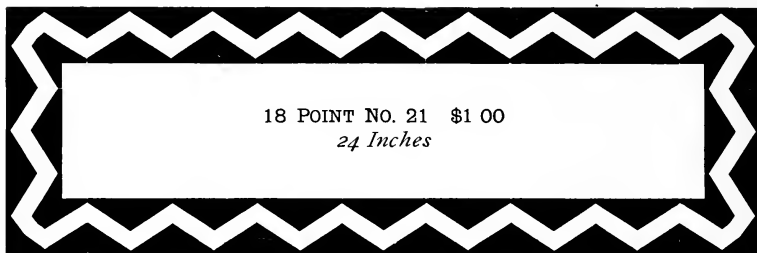

NEWSPAPER BORDERS

15



18 POINT NO. 19 \$1 00  
*24 Inches*



24 POINT NO. 3 \$1 50  
*24 Inches*

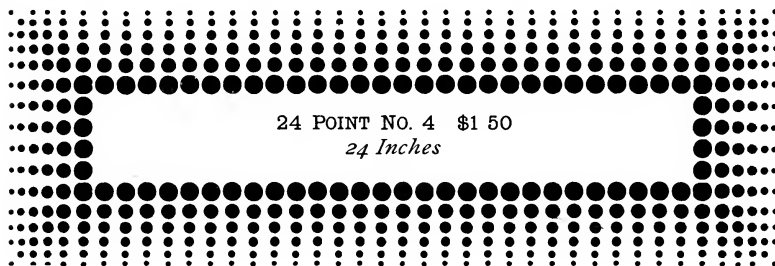

24 POINT NO. 4 \$1 50  
*24 Inches*

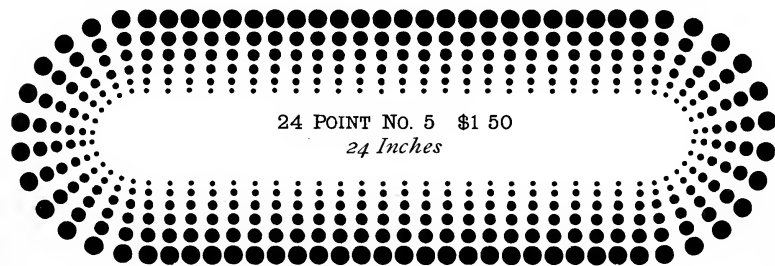

24 POINT NO. 5 \$1 50  
*24 Inches*

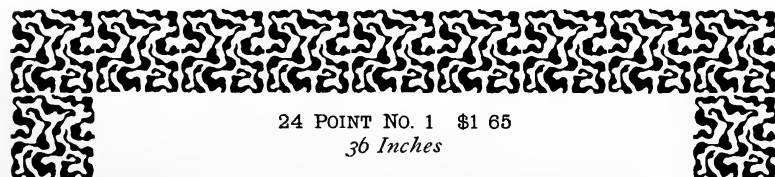

24 POINT NO. 1 \$1 65  
*36 Inches*

**BARTA BORDERS**

48 POINT NO. 283

12 INCHES \$1 50



30 POINT NO. 251

20 INCHES \$1 50



18 POINT NO. 241

30 INCHES \$1 50



18 POINT NO. 248

30 INCHES \$1 50



18 POINT NO. 250

30 INCHES \$1 50



14 POINT NO. 245

30 INCHES \$1 50



12 POINT NO. 282

36 INCHES \$1 50



12 POINT NO. 285

36 INCHES \$1 50



12 POINT NO. 286

36 INCHES \$1 50



BARTA BORDERS

36 POINT NO. 254

18 INCHES \$1 50



30 POINT NO. 243

20 INCHES \$1 50



24 POINT NO. 242

20 INCHES \$1 50



18 POINT NO. 249

30 INCHES \$1 50



18 POINT NO. 246

30 INCHES \$1 50



24 POINT NO. 284

20 INCHES \$1 50



18 POINT NO. 291

30 INCHES \$1 50



12 POINT NO. 244

36 INCHES \$1 50



12 POINT NO. 292

36 INCHES \$1 50



HALF NONPAREIL BORDERS

11

COMPLETE FONT \$2 25 10 FEET LONG

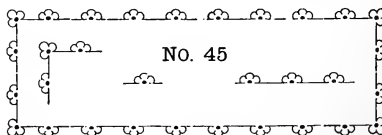
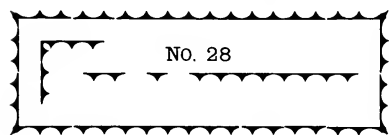
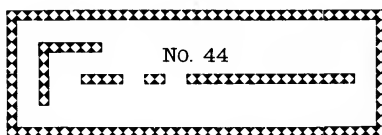
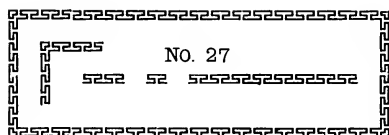
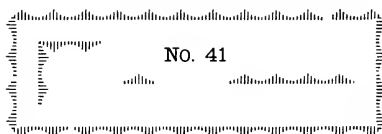
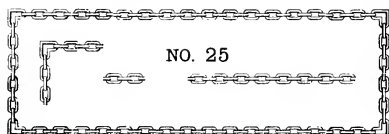
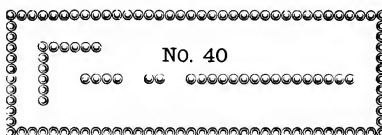
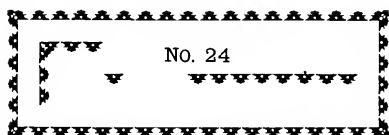
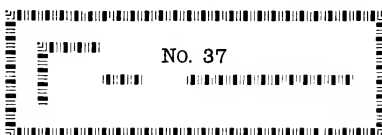
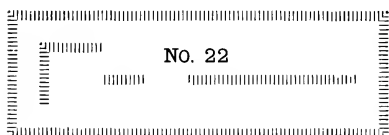
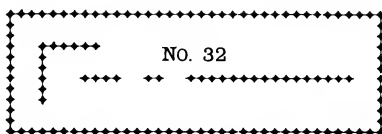
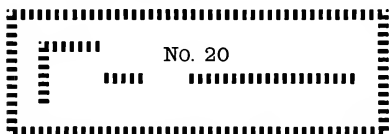
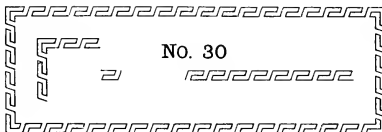
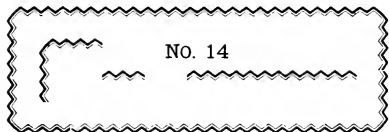
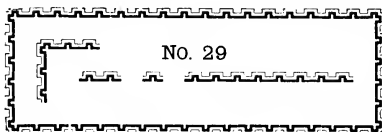
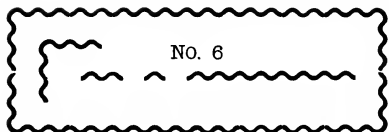

NONPAREIL BORDERS

11

COMPLETE FONT \$2 60 10 FEET LONG

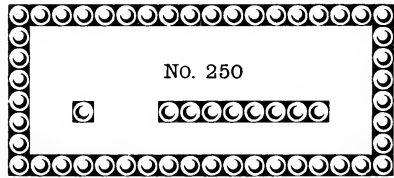
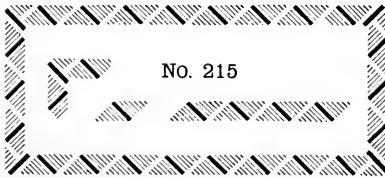
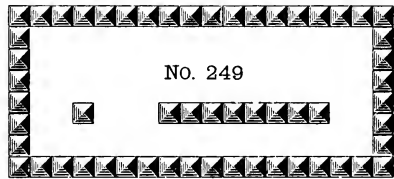
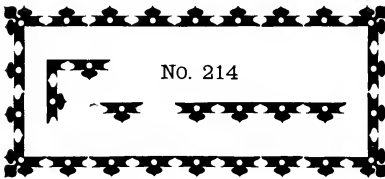
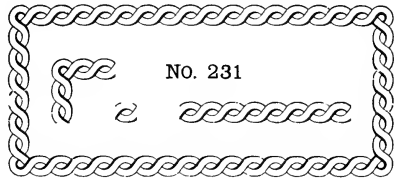
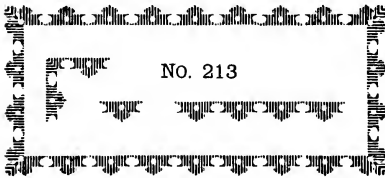
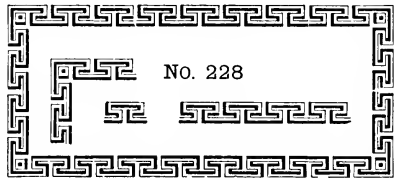
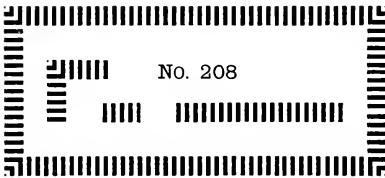
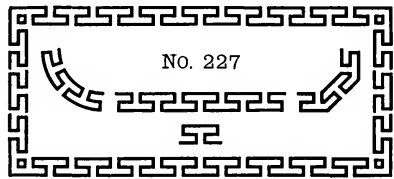
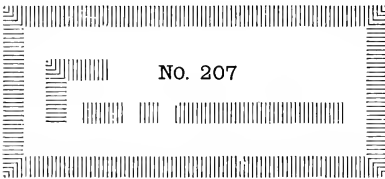
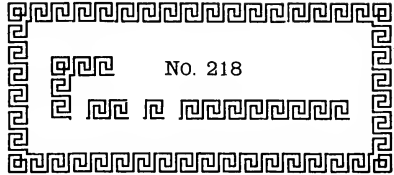
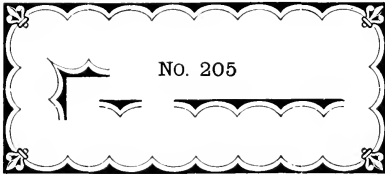

PICA BORDERS

11

COMPLETE FONTS \$3 00 10 FEET LONG

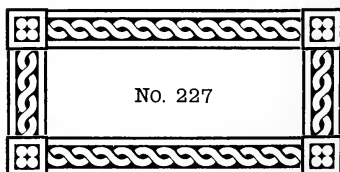
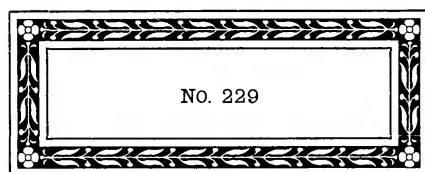
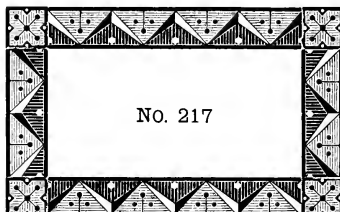
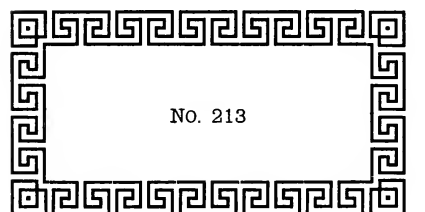
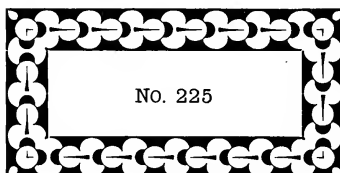
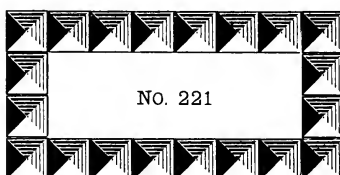
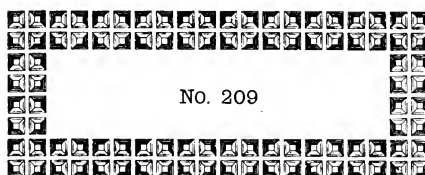
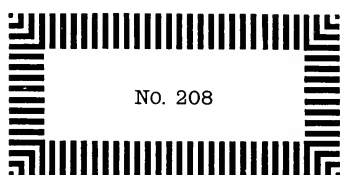
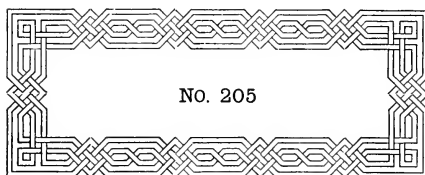



**CHRISTMAS ORNAMENTS**

282A. 15 cts.



288A. 15 cts.



280A. 40 cts.



287A. 15 cts.



284A. 15 cts.



278A. 15 cts.



276A. 15 cts.



*All characters except 280A put up in sets of four at 50 cents per set*

**MURAL ORNAMENTS**

292A. 30 cts.



291A. 15 cts.



312A. 15 cts.

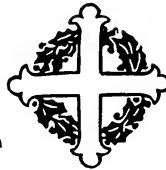

314A. 15 cts.

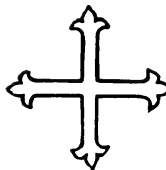

311A. 15 cts.



305A. 15 cts.

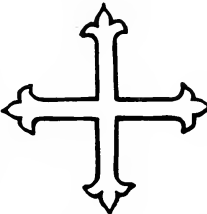

306A. 15 cts.

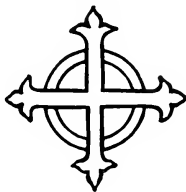

310A. 15 cts.



290A. 15 cts.



309A. 15 cts.

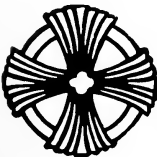

295A. 15 cts.

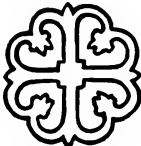

294A. 15 cts.



296A. 15 cts.



316A. 15 cts.



304A. 15 cts.



297A. 15 cts.



303A. 15 cts.



298A. 15 cts.



301A. 15 cts.



*All characters except 292A put up in sets of four at 50 cents per set. Characters Nos. 291A and 292A may be used for two-color initials*

**SPEAKERS**

12  
 LARGE FONT \$2 50  
 SMALL FONT \$1 50

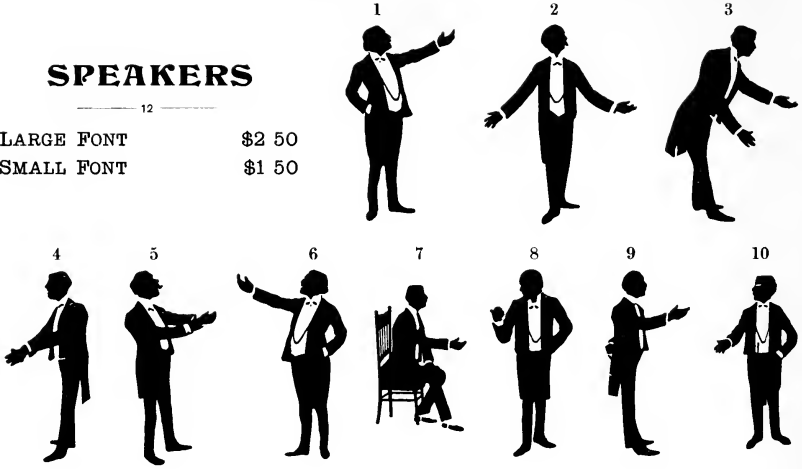

The idea of making series of type pictures for embellishing advertisements was originated by the AMERICAN TYPE FOUNDERS' COMPANY.

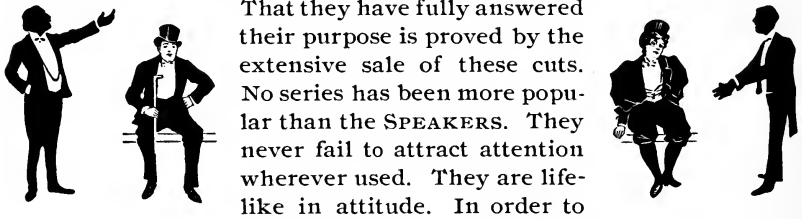

That they have fully answered their purpose is proved by the extensive sale of these cuts. No series has been more popular than the SPEAKERS. They never fail to attract attention wherever used. They are life-like in attitude. In order to

extend the usefulness of the SPEAKERS, the LISTENERS have been designed as a good companion series.

**LISTENERS**

12  
 PER FONT \$1 50

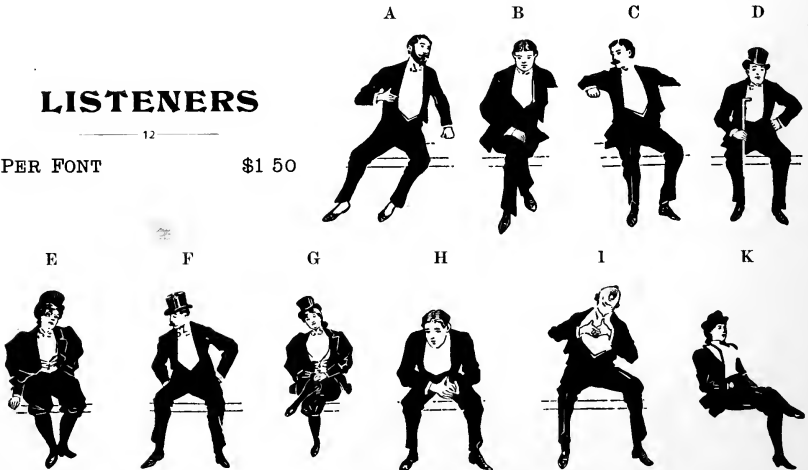

### COPPERS

— 15 —

PER FONT

\$1 50

1



2



3



4



5



6



7



8



9



10



### RIGS AND TRAPS

— 15 —

PER FONT

\$1 50

1



2



3



4



5



6



7



8



### Large Scorchers

PER FONT

\$2 50

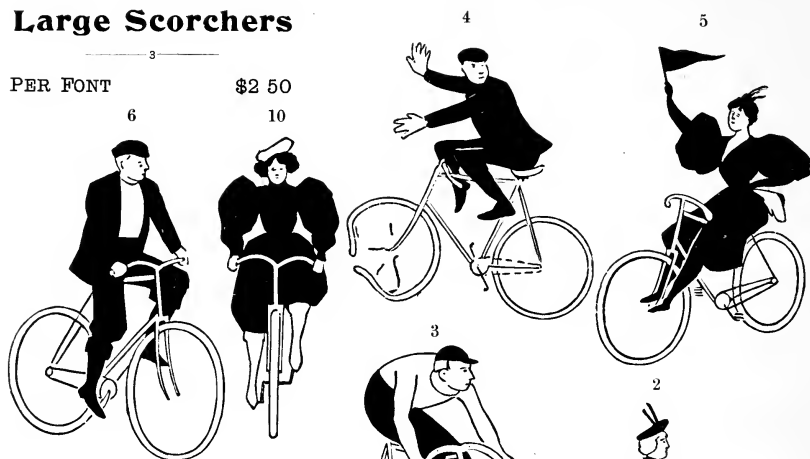

### Small Scorchers

PER FONT

\$1 50

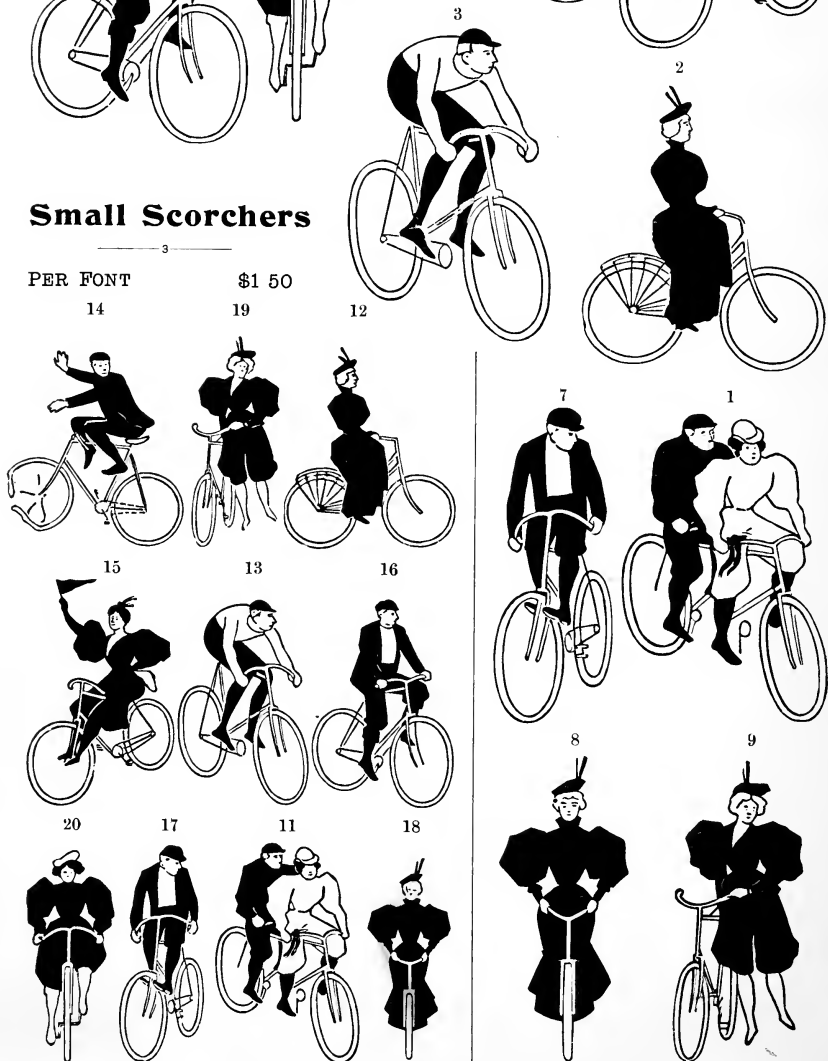

**BALLET DANCERS**

PER FONT \$2 00



**BASEBALL**  
Series No. 1

LARGE FONT \$2 50  
SMALL FONT 1 50

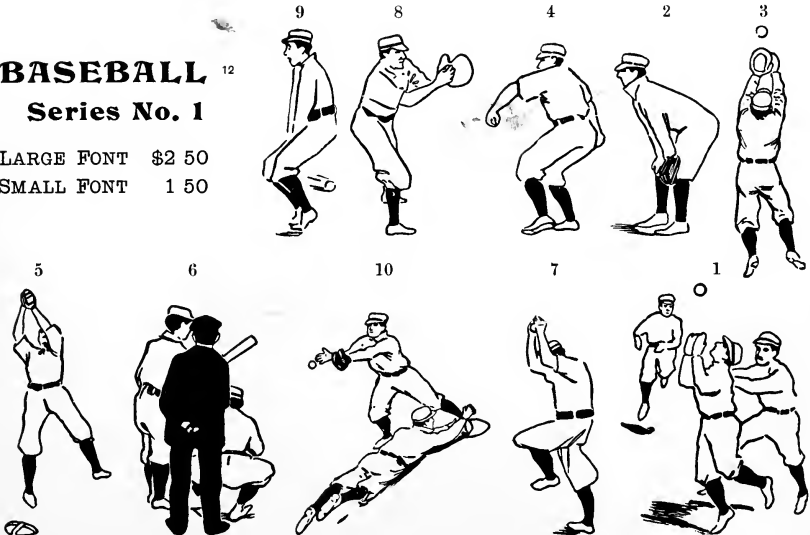

**DOMESTICS**

15

PER FONT

\$1 50



**Delmonico's Chefs and Waiters**

15

PER FONT

\$1 50



COPPER ALLOY TYPE

**BOWLERS**

PER FONT \$1 75

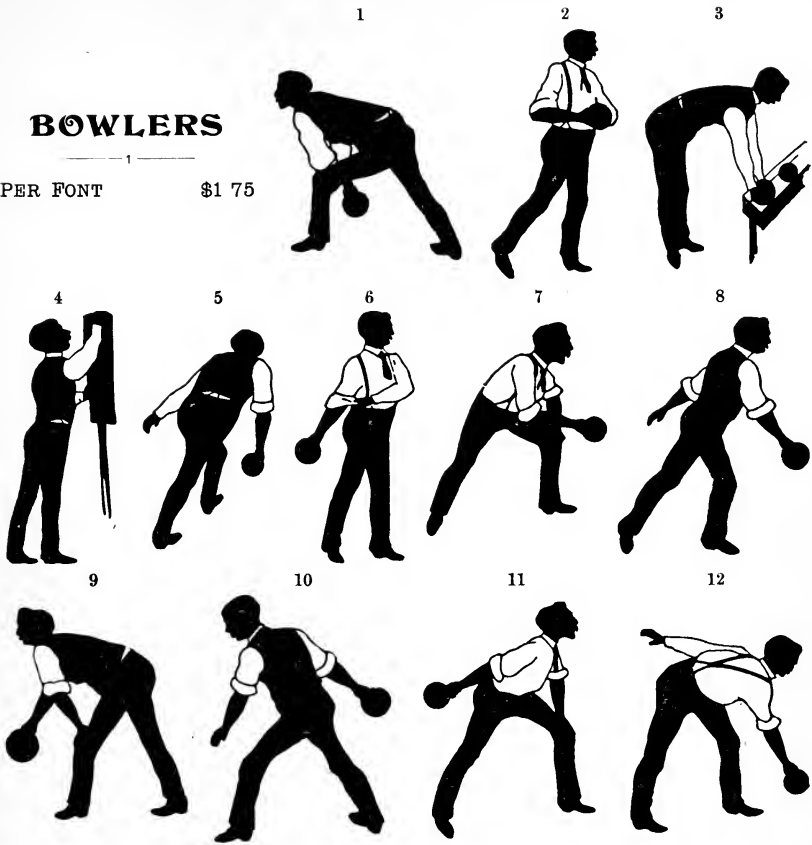

**PICK-UPS**

PER FONT \$1 75

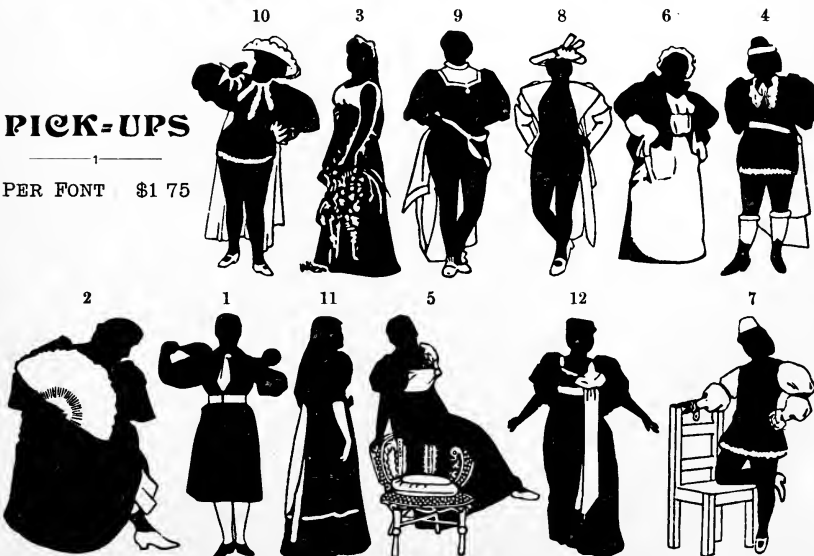

**CAMPAIGNERS**

PER FONT

\$1 75



**SILHOUETTES**

PER FONT

\$1 75





**SLOCUM SEALS**

—12—

PER FONT

\$1 50

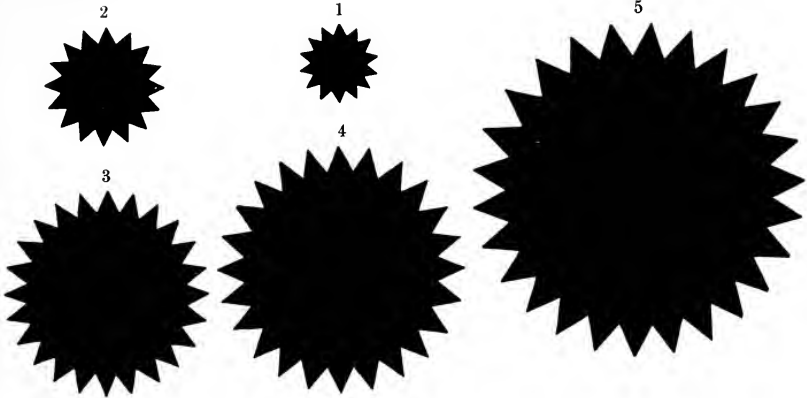

*Cast on 24, 36, 60, 72 and 96 Point body*

**INSECTS**

—15—

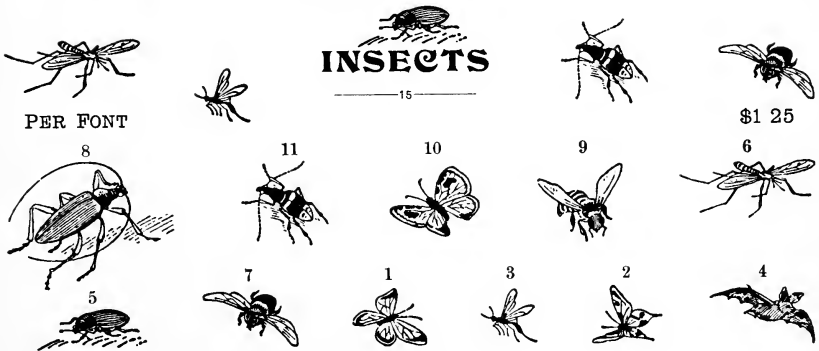

PER FONT

\$1 25

**INK SPOTS**

—12—

PER FONT

\$1 25

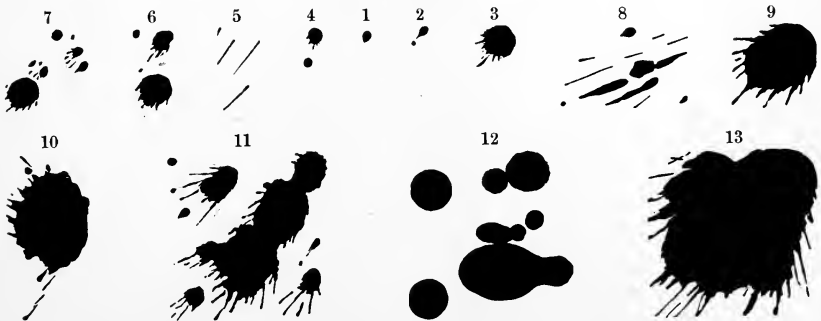

**ELECTROTYPED DATE LINES**

—15—

STYLE NO. 1F 75 CTS.

*Dallas, Tex.,* ..... 189

STYLE NO. 2F 75 CTS.

*Topeka, Kas.,* ..... 189

STYLE NO. 3F 75 CTS.

*Denver, Colo.,* ..... 189

STYLE NO. 4F 75 CTS.

*Texarkana, Ark.,* ..... 189

STYLE NO. 5F 75 CTS.

*Kansas City, Mo.,* ..... 189

STYLE NO. 6F 75 CTS.

*Detroit,* ..... 189

STYLE NO. 7F 75 CTS.

*Chester, Tex.,* ..... 189

STYLE NO. 8F 75 CTS.

*Boise City, Idaho,* ..... 189

STYLE NO. 9F 75 CTS.

*Omaha, Neb.,* ..... 189

STYLE NO. 11F 75 CTS.

*Portland, Ore.,* ..... 189

ELECTROTYPED DATE LINES

12-15

STYLE NO. 12F 75 CTS.

*Sacramento, Cal.,* ..... 189

STYLE NO. 13F 75 CTS.

*Jefferson City, Mo.,* ..... 189

STYLE NO. 14F 75 CTS.

*Salt Lake City, Utah,* ..... 189

STYLE NO. 15F 75 CTS.

*Lincoln, Neb.* ..... 189

STYLE NO. 16F 75 CTS.

*St. Louis, Mo.,* ..... 189

STYLE NO. 17F 75 CTS.

*Minneapolis, Minn.,* ..... 189

STYLE NO. 18F 75 CTS.

*Des Moines, Iowa,* ..... 189

STYLE NO. 19F 75 CTS.

*Salem, Ore.,* ..... 189

STYLE NO. 20F 75 CTS.

*Boise City, Idaho,* ..... 189

STYLE NO. 69½E 75 CTS.

*Hartford, Ind.,* ..... 189

STYLE NO. 127E 75 CTS.

*New Orleans,* ..... 189

**COMMERCIAL LOGOTYPES**

*Electrotyped Lines in Spencerian Scripts supplied at prices quoted below:*

No. 501C. 10c. <i>189</i>	No. 502C. 10c. <i>189</i>	No. 503C. 10c. <i>189</i>	No. 504C. 10c. <i>189</i>	No. 508C. 10c. <i>Dr</i>
No. 516C. 10c. <i>Cr</i>	No. 512C. 10c. <i>M</i>	No. 513C. 10c. <i>M</i>	No. 509C. 10c. <i>To</i>	No. 514C. 10c. <i>No.</i>
No. 511C. 10c. <i>M</i>	No. 2405F. 15c. <i>M</i>	No. 4139F. 15c. <i>M</i>	No. 515C. 10c. <i>No.</i>	No. 548C. 15c. <i>No.</i>
No. 546C. 15c. <i>M</i>	No. 547C. 15c. <i>M</i>	No. 549C. 15c. <i>No.</i>	No. 544C. 15c. <i>Dr</i>	
No. 3992F. 20c. <i>To</i>	No. 3988F. 20c. <i>Dr.</i>	No. 3989F. 20c. <i>Cr.</i>	No. 566C. 30c. <i>Received</i>	
<i>Received</i>			<i>Lincoln Dollars</i>	
<i>Solid-body Electros, set in 28 Point Spencerian Script No. 2, as shown in line above, furnished at 25 cents per lineal inch</i>				
<i>Milwaukee</i>			<i>Dollars</i>	
<i>Solid-body Electros, set in 40 Point Spencerian Script No. 2, as shown in line above, furnished at 30 cents per lineal inch</i>				

**BILLHEAD LOGOTYPES**

*Original. Copyrighted. All cast in a Mould*

PER FONT

\$5 00

No. 105C. 40 cts.



No. 99C. 35 cts.



No. 95C. 40 cts.



No. 103C. 40 cts.



No. 92C. 30 cts.



No. 106C. 40 cts.

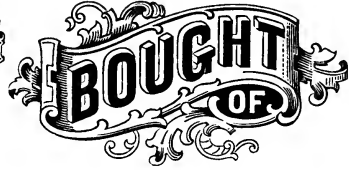

No. 100C. 40 cts.



No. 94C. 40 cts.



No. 97C. 40 cts.



No. 102C. 40 cts.



No. 101C. 40 cts.



No. 96C. 40 cts.



No. 93C. 35 cts.



No. 104C. 40 cts.



No. 108C. 40 cts.



No. 107C. 40 cts.

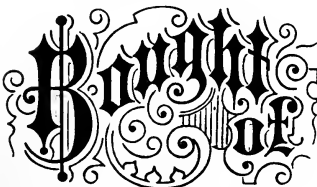

No. 98C. 35 cts.



No. 109C. 40 cts.



CHECK AND BILL BLANKS

Add the words "Check Blank" or "Bill Blank" and Initial to the No. wanted

No. 328C. 75 cts.

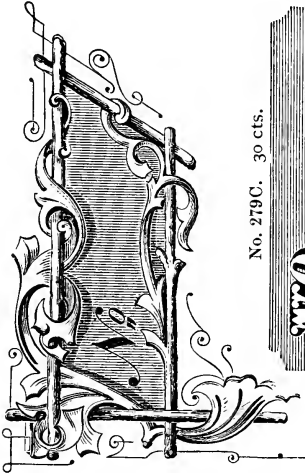

No. 279C. 30 cts.

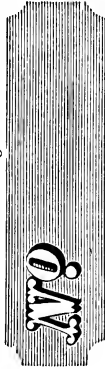

No. 280C. 30 cts.



No. 328½C. 75 cts.

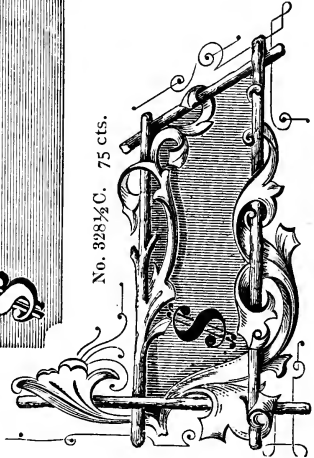

No. 330C. 30 cts.



No. 329C. 40 cts.



*These Check and Bill Blanks are original with us. This Company originated nine-tenths of all the cuts used by printers*

No. 323C. 75 cts.

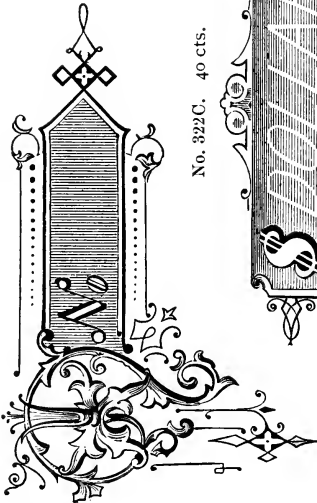

No. 322C. 40 cts.

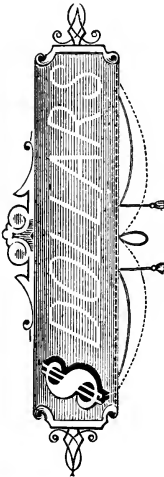

No. 321C. 40 cts.

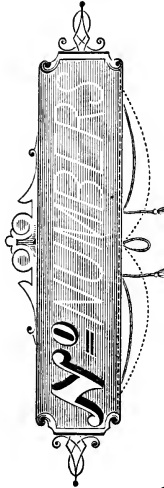

No. 323½C. 75 cts.

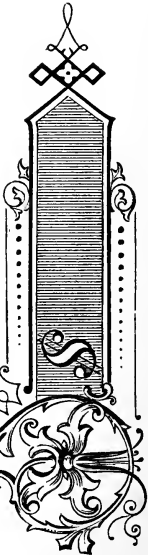

CHECK AND BILL BLANKS

No. 319C. 50 cts.

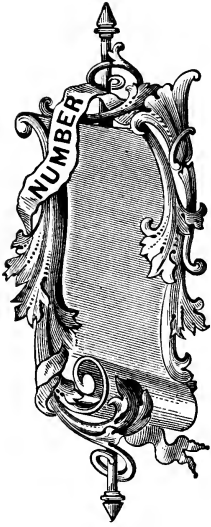

No. 270C. 30 cts.



No. 269C. 30 cts.



No. 320C. 50 cts.

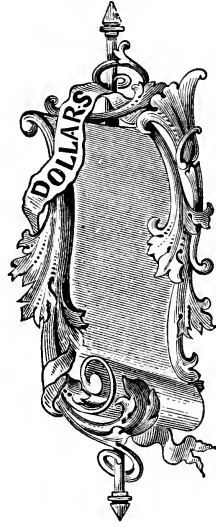

No. 304C. 40 cts.

No. 305C. 40 cts.

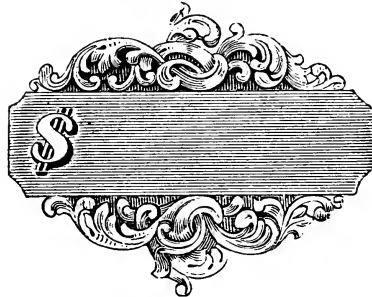

No. 295C. 40 cts.

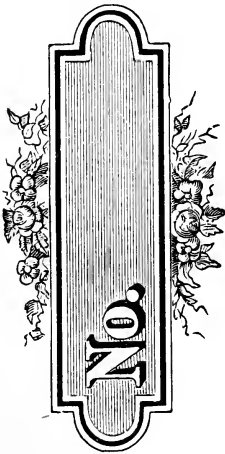

No. 297C. 40 cts.



No. 296C. 40 cts.

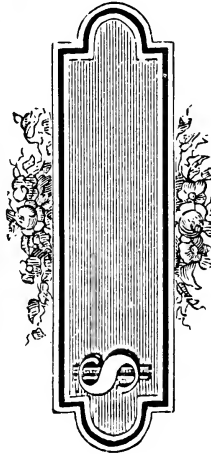





MISCELLANEOUS CAST CUTS.

731E. 25c.



711E. 25c.



709E. 25c.



917E. 30c.



2657F. 20c.



4118F. 25c.



732E. 25c.



4117F. 25c.



4057F. 20c.



255E. 12c.



717E. 25c.



468E. 20c.



804E. 25c.

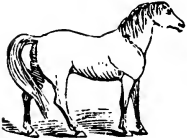

730E. 25c.



511E. 15c.



4149F. 30c.



465E. 15c.



858E. 30c.



4099F. 30c.



4126F. 30c.



4121F. 30c.



4122F. 30c.



4124F. 30c.



4125F. 30c.



4123F. 35c.



4120F. 35c.



NEWSPAPER SUB-HEADINGS

TRIMMED TO 13 EMS PICA

PRICE 50 CENTS EACH

ORDER BY NO. AND INITIAL

No. 54E  
**Boston Review.**

No. 26E  
**DENVER RECORD.**

No. 23E  
**MORNING WORLD.**

No. 27E  
**DAILY TRUTH.**

No. 21E  
**RACINE REPUBLICAN.**

No. 22E  
**MORNING JOURNAL.**

No. 28½E  
**BICYCLE REVIEW.**

No. 38E  
**The Chicago Bulletin.**

No. 33E  
**Evening Recorder.**

No. 32E  
**The Illinois Independent.**

No. 14E  
**The Weekly Reporter.**

No. 16E  
**Iowa Friday Globe.**

No. 18E  
**Evening Graphic.**

No. 53E  
**The Duluth Signal.**

**NEWSPAPER HEADINGS**  
**Price List**

WIDTH OF HEADING	BODY—PICA MEASUREMENT						
	4-LINE	5-LINE	6-LINE	7-LINE	8-LINE	9-LINE	10-LINE
4 Column . . .	\$2 00	\$2 25	\$2 50	\$2 75	\$3 00	\$3 25	\$3 50
5 " . . .	2 25	2 50	2 75	3 00	3 25	3 50	3 75
6 " . . .	2 50	2 75	3 00	3 25	3 50	3 75	4 00
7 " . . .	2 75	3 00	3 25	3 50	3 75	4 00	4 25
8 " . . .	3 00	3 25	3 50	3 75	4 00	4 25	4 50
9 " . . .	3 25	3 50	3 75	4 00	4 25	4 50	4 75

STYLE NO. 109

B 12

FOUR-LINE PICA

**Landmark**

STYLE NO. 102

B 12

FIVE-LINE PICA

**SUNBEAM**

STYLE NO. 105

B 11, 12 AND 15

FOUR-LINE PICA

**MINER**

STYLE NO. 108

B 11 AND 12

SIX-LINE PICA

**STAR**

**NEWSPAPER HEADINGS**—See Page 721 for Prices

STYLE NO. 107

B 11

SIX-LINE PICA

ERA

STYLE NO. 112

B 4

FIVE-LINE PICA

CASK

STYLE NO. 146

B 4

FOUR-LINE PICA

EAGLE

STYLE NO. 115

B 15

FIVE-LINE PICA

BEACON

STYLE NO. 124

B 15

SIX LINE PICA

Express

**NEWSPAPER HEADINGS**—See Page 721 for Prices

STYLE NO. 125

B 2 AND 15

SIX-LINE PICA

**TOCSIN**

STYLE NO. 127

B 15

SIX-LINE PICA

**MUSIC**

STYLE NO. 129

B 15

SIX-LINE PICA

**Alarm**

STYLE NO. 130

B 15

SIX-LINE PICA

**HOUR**

STYLE NO. 137

B 15

SIX-LINE PICA

**Market**

**NEWSPAPER HEADINGS**—See Page 721 for Prices

STYLE NO. 118

B 14

SIX-LINE PICA

TIMES

STYLE NO. 120

B 11 AND 12

FIVE-LINE PICA

Postman

STYLE NO. 121

B 11 AND 12

FIVE-LINE PICA

CHURCH

STYLE NO. 122

B 11 AND 12

FIVE-LINE PICA

Printer

STYLE NO. 123

B 11 AND 12

FIVE-LINE PICA

MAIL

**NEWSPAPER HEADINGS**—See Page 721 for Prices

STYLE NO. 135

B 11, 12 AND 15

FIVE-LINE PICA

Turf News

STYLE NO. 138

B 11 AND 15

SIX-LINE PICA

Monthly

STYLE NO. 141

B 11 AND 12

SEVEN-LINE PICA

Tribune

STYLE NO. 143

B 11 AND 12

EIGHT-LINE PICA

Times

STYLE NO. 144

B 12

FIVE-LINE PICA

Wickblatt

STATE SEALS

No. 2781C. 75 cts.



IOWA

No. 2791C. 75 cts.



KANSAS

No. 3701C. \$1.50



COLORADO

No. 2796C. 75 cts.

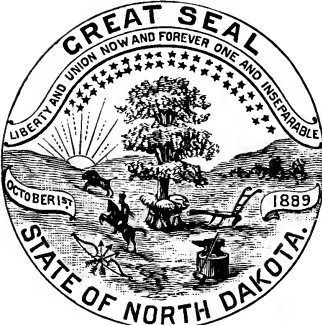

NORTH DAKOTA

No. 2797C. 75 cts.



SOUTH DAKOTA

*Seals of all the States in the Union, uniform with any shown on this page, furnished at the same prices*



COPPER ALLOY TYPE

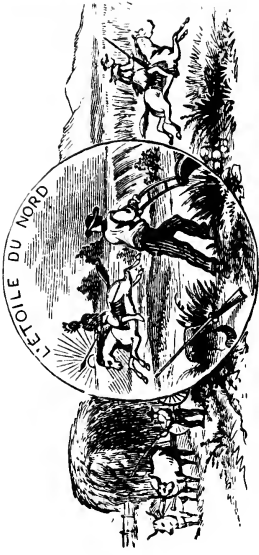

No. 3131C.  
\$1.00  
MINNESOTA

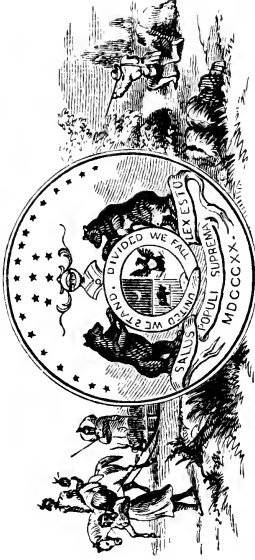

No. 3128C.  
\$1.00  
MISSOURI

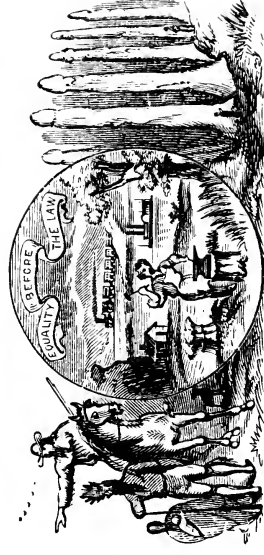

No. 3140C.  
\$1.00  
NEBRASKA



No. 3127C.  
\$1.00  
ILLINOIS



No. 3126C.  
\$1.00  
INDIANA

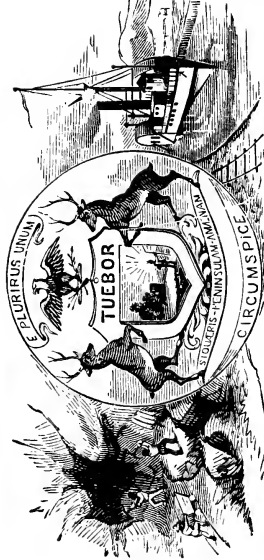

No. 3125C.  
\$1.00  
MICHIGAN

Seals of all the States in the Union, uniform with any shown on this page, furnished at the same prices

AMERICAN TYPE FOUNDERS CO.

No. 2389C. \$1.00



No. 2471C. 50 cts.



No. 2752C. 75 cts.



No. 3182C. 75c.

No. 4100F. 25c.

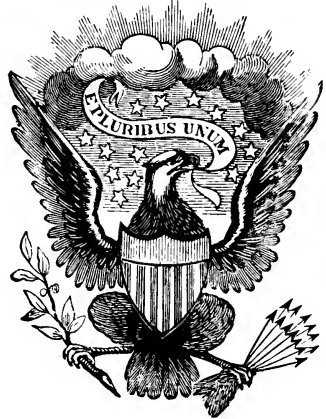

No. 2443C. 30 cts.



No. 2213½C. \$1.50

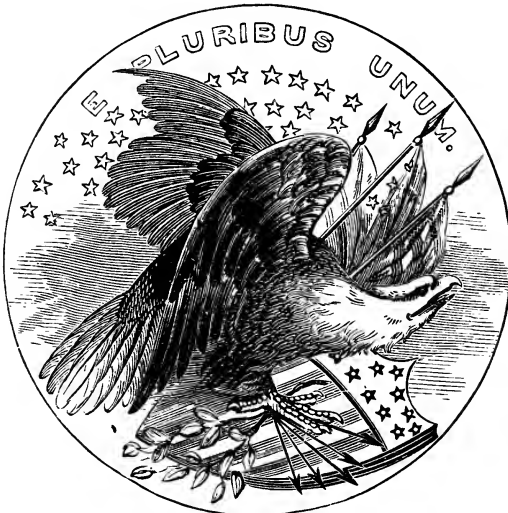

No. 514E. 25 cts.



No. 857E. 30 cts.



No. 3023C. 25 cts.



COPPER ALLOY TYPE

No. 4141C. 75 cts.



No. 2708C. \$1.50



No. 162B. \$1.25



No. 2459C. 37c.



No. 4148C. 40 cts.

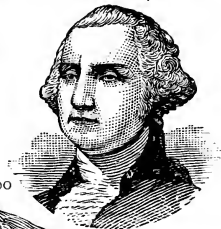

No. 3818C. \$1.00

No. 2904C. 50 cts.

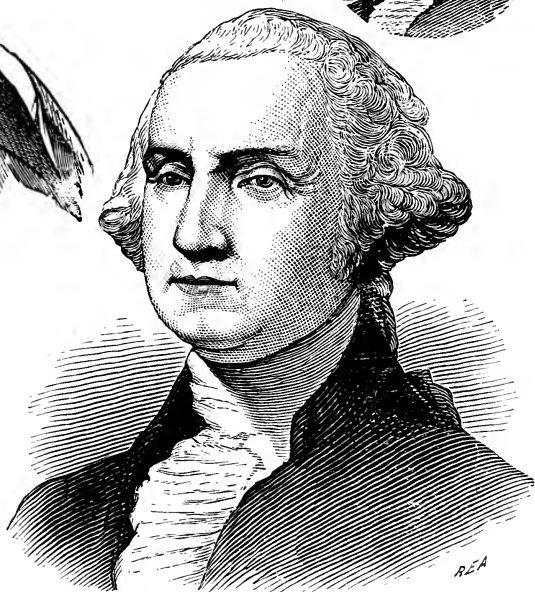

SOCIETY EMBLEMS

No. 241B. 40 cts.



No. 216B. 90 cts.

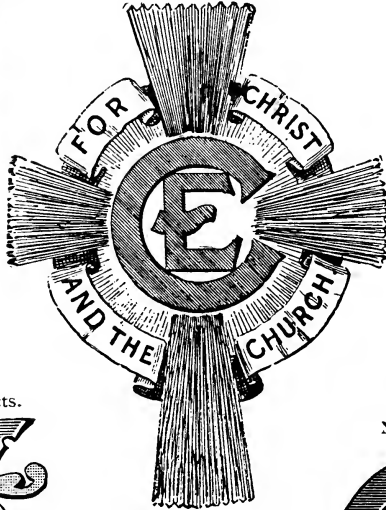

No. 235B. 40 cts.



No. 245B. 35 cts.



No. 243B. 40 cts.



No. 237B. 70 cts.

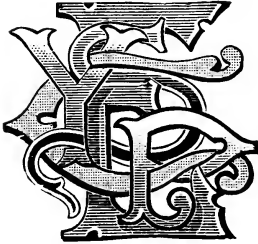

No. 214B. 60 cts.

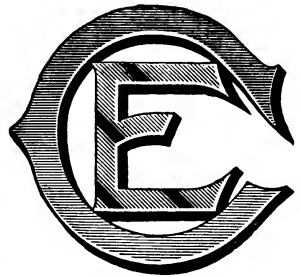

For two colors, \$1 50

No. 229B. 50 cts.



No. 242B. 40 cts.



No. 239B. 90 cts.



No. 4153C. 30c.



No. 227B. 50 cts.



No. 217B. 35 cts.

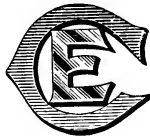

No. 278B. 40 cts.



No. 222B. 40 cts.



For two colors, \$1.50

COPPER ALLOY TYPE

No. 238B. 75 cts.



No. 234B. 75 cts.



No. 215B. 75 cts.



No. 232B. 60 cts.

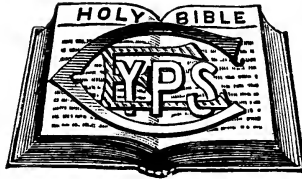

No. 221B. 40 cts.



No. 240B. 40 cts.



No. 223B. 50 cts.

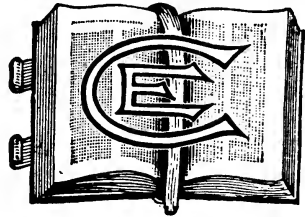

No. 220B. 35 cts.



No. 224B. 60 cts.



No. 225B. 60 cts.

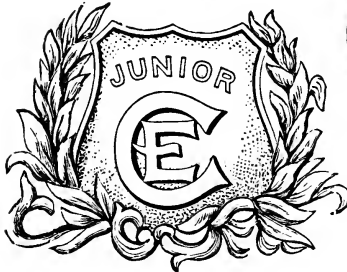

For two colors, \$1.00

No. 233B. 50 cts.

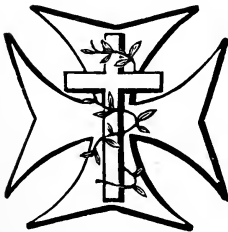

No. 228B. 75 cts.



AMERICAN TYPE FOUNDERS CO.

No. 3083A. \$1.00



No. 3079A. \$1.00



No. 168B. 75 cts.

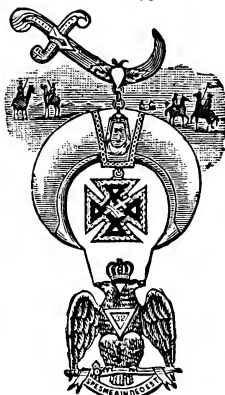

No. 3327A. 75 cts.



No. 3066A. 75 cts.



No. 4140C. \$1.00



No. 1850A. 40 cts.



No. 3077A. 40 cts.



No. 3078A. 75 cts.

No. 3059A. 75 cts.

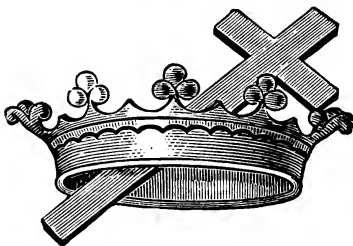

No. 3027A. 30 cts.

No. 3653C. 35 cts.

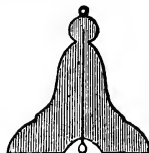

COPPER ALLOY TYPE

No. 3044A. 75 cts.



No. 3401C. 50 cts.



No. 3323A. 60 cts.

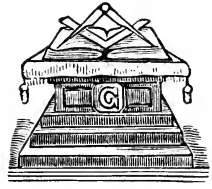

No. 3109 A. 35c.



No. 170B. 40c.



No. 3402C. 50 cts.



No. 3403C. 50 cts.



No. 165B. 30c.



No. 3404C. 50 cts.



No. 3400C. 50 cts.



No. 3399C. 50 cts.



No. 166B. 30c.



No. 2079 A. 50 cts.



No. 432E. 25c.



No. 172B. 25c.



No. 2432C. 50 cts.



No. 180B. 30 cts.



No. 2431C. \$1.00

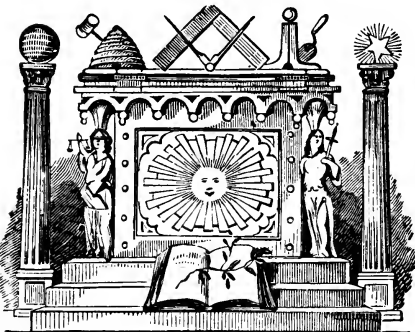

No. 4123C. 75 cts.

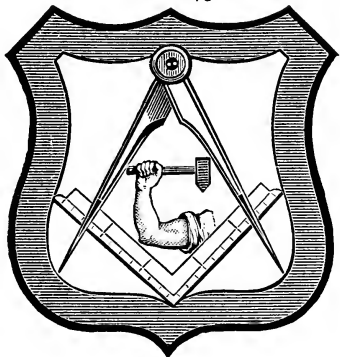

AMERICAN TYPE FOUNDERS CO.

No. 174B. \$1.00



For two colors, \$1.50

No. 2970C. 50 cts.

No. 176B. \$1.00

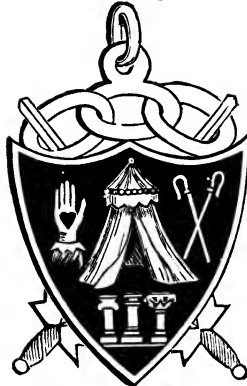

For two colors, \$1.50

No. 3119A. 75 cts.

No. 3123A. \$1.00



No. 3121A. \$1.00



No. 1116F. 40 cts.

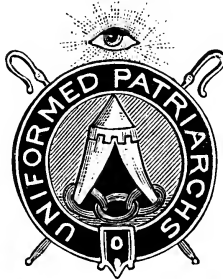

No. 3099A. 30 cts.

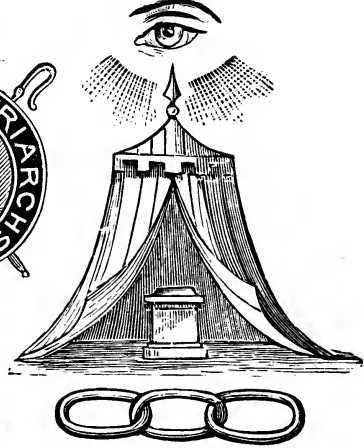

No. 3122A. \$1.00



No. 175B. \$1.00





COPPER ALLOY TYPE

No. 3185A. \$1.00



No. 3118A. 75 cts.

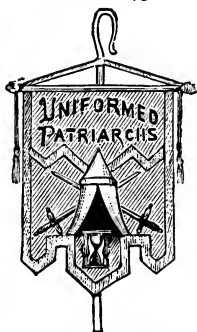

No. 3661C. 30c.



No. 3110A. 40 cts.



No. 173B. 25 cts.



No. 181B. 60 cts.



No. 3024A. 30c.



No. 191B. 50 cts.



No. 177B. 35 cts.



No. 3972C. 60 cts.



No. 3418C. 60 cts.



No. 3191A. 75 cts.



No. 185B. \$1.00



No. 3152A. \$1.00



AMERICAN TYPE FOUNDERS CO.

No. 267B. 75 cts.



No. 3126A. 60 cts.



No. 3419C. 75 cts.



No. 190B. \$1.25



No. 2601A. 65 cts.

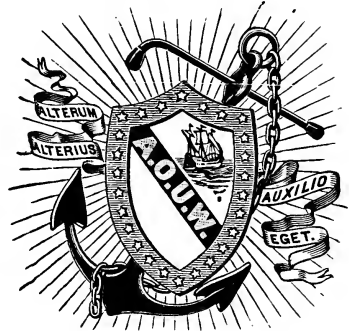

No. 3147A. 50 cts.



No. 184B. 90 cts.

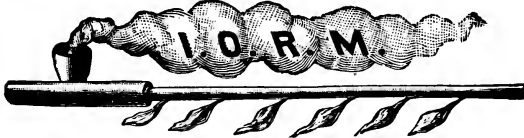

No. 3996C. 75 cts.



No. 254B. \$1.00

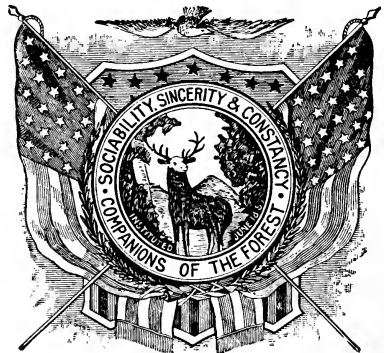

COPPER ALLOY TYPE

No. 3168A. 60 cts.



No. 3186A. \$1.00



No. 3089A. 75 cts.



No. 3129A. 60 cts.



No. 3136A. 60 cts.



No. 2820A. 50 cts.



No. 3658C. 35 cts.

No. 3657C. 40 cts.

No. 3133A. 60 cts.

No. 247B. 50 cts.



No. 3171A. \$1.00



No. 2319½A. 75 cts.



No. 3154A. \$1.00



No. 203B. \$1.00



No. 260B. 75 cts.



No. 207B. 90 cts.



No. 3167A. \$1.00

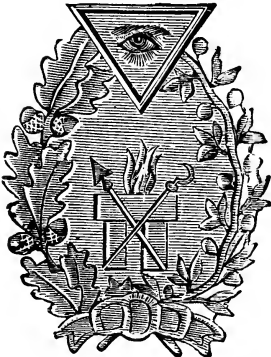

No. 251B. 50 cts.



No. 3146A. 60 cts.



No. 252B. 50 cts.



No. 257B. 60 cts.



No. 3189A. 50 cts.



COPPER ALLOY TYPE

No. 204B. 90 cts.

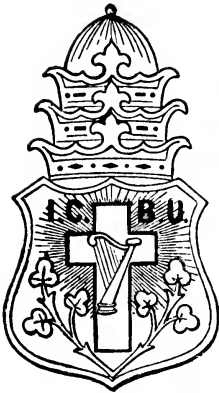

No. 268B. \$1.15

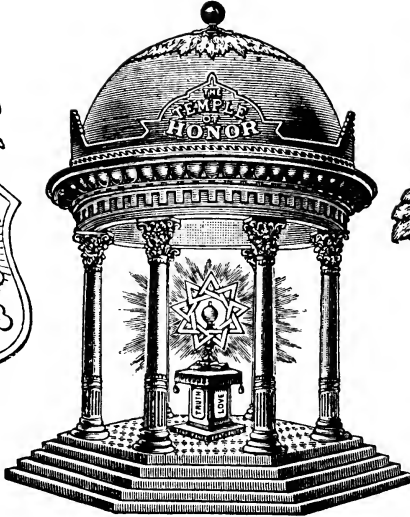

No. 262B. 75 cts.



No. 3659C. 40 cts.



No. 3141A. 50 cts.



No. 3144A. 60 cts.

No. 206B. 60 cts.

No. 4185C. 75 cts.

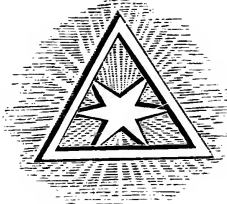

No. 3149A. 75 cts.

No. 250B. 50 cts.

No. 3142A. 50 cts.

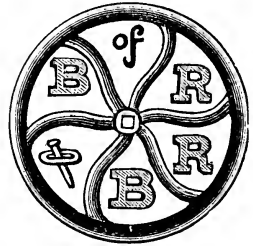

No. 205B. 75 cts.

No. 211B. 75 cts.

No. 3143A. 60 cts.

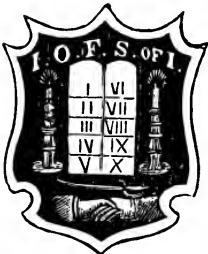

AMERICAN TYPE FOUNDERS CO.

No. 1873D. 60 cts.



No. 209B. 50 cts.



No. 3161A. 75 cts.

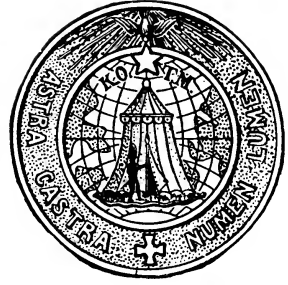

No. 3172A. 50 cts.



No. 234A. 40 cts.



No. 256B. 75 cts.



No. 208B. 40 cts.



No. 1874D. 75 cts.



No. 987A. 60 cts.



No. 3196A. \$1.25.



No. 3198A. \$1.00



COPPER ALLOY TYPE

No. 3955C. 60 cts.

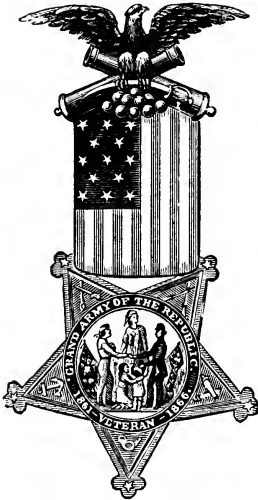

Larger sizes furnished

No. 202B. 75 cts.

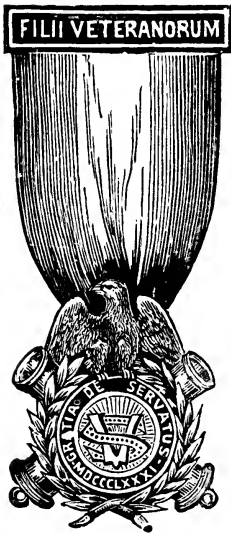

No. 193B. 45 cts.

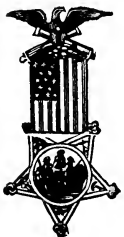

No. 3174A. 60 cts.



No. 4125C. 40 cts.



No. 198B. 60 cts.



No. 2022E. \$1.00

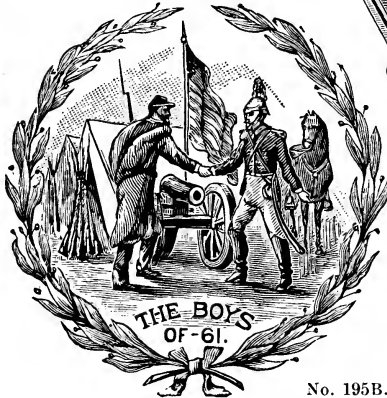

No. 195B. 75 cts.



No. 3953C. 75 cts.

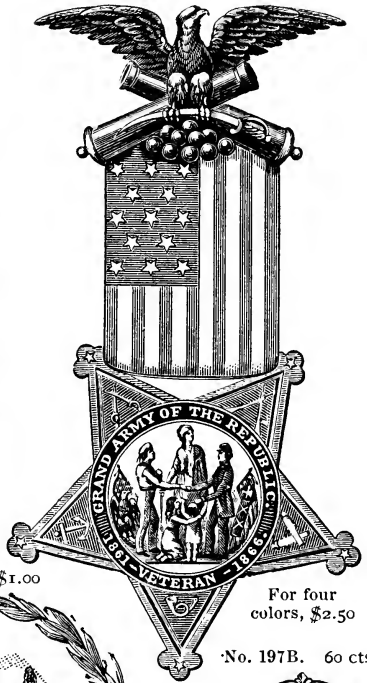

No. 197B. 60 cts.

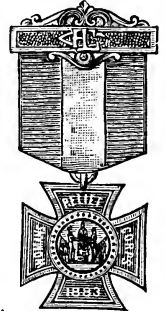

For four colors, \$2.50

AMERICAN TYPE FOUNDERS CO.

No. 2057E. \$1.00

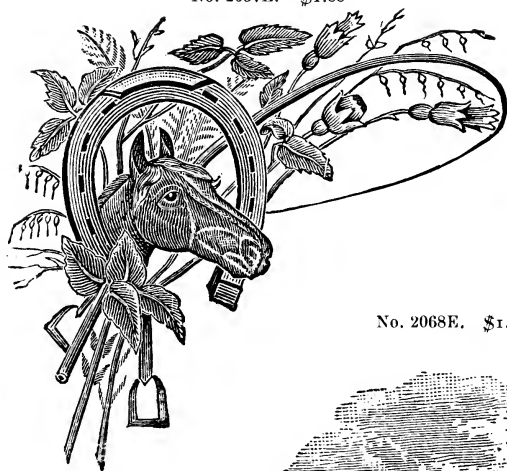

No. 3370C. 50 cts.

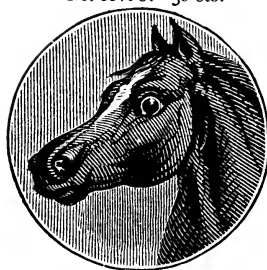

No. 2068E. \$1.00

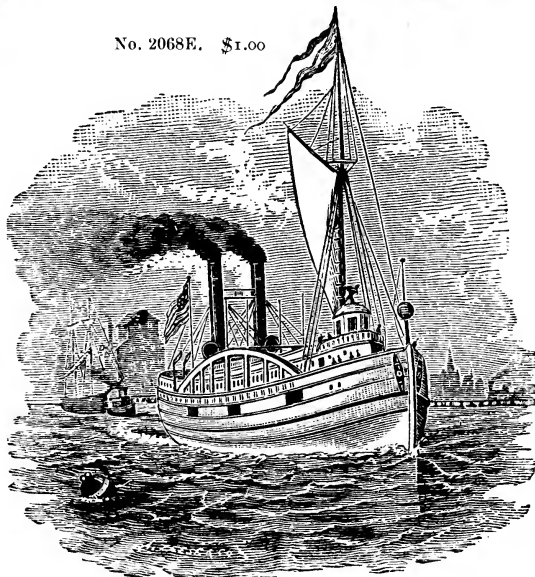

No. 2076E. 50 cts.



No. 3062C. 30 cts.

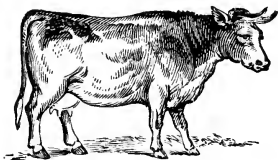

No. 1856C. 50 cts.



No. 1629D. 75 cts.

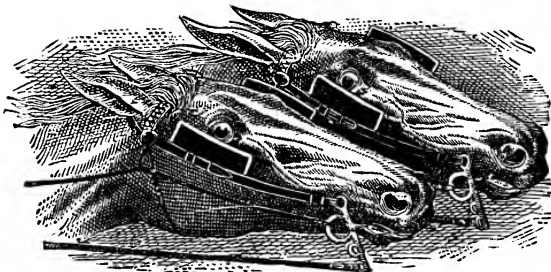

No. 3452C. 30 cts.





COPPER ALLOY TYPE

No. 4120C. 75 cts.

(No. 3997C. 75 cts. Same cut without the initials.)

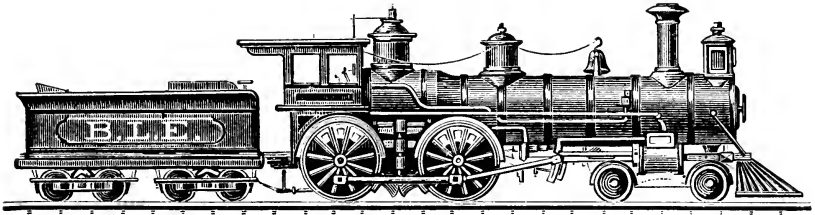

No. 2060E. 90 cts.

No. 2058E. 90 cts.

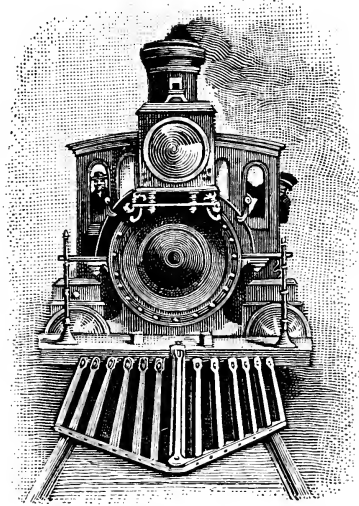

No. 4168C. 60 cts.

No. 4167C. 40 cts.

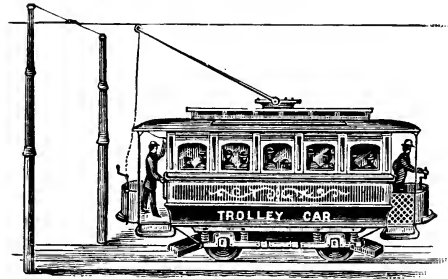
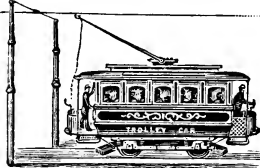

No. 2807C. \$1.00

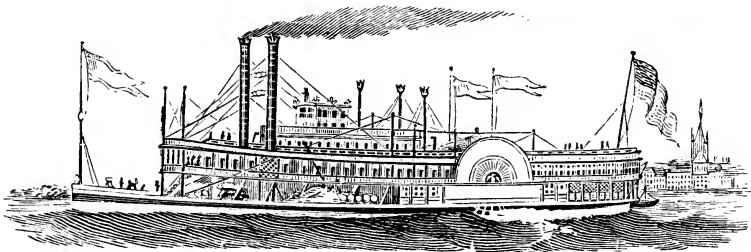

AMERICAN TYPE FOUNDERS CO.

No. 2678C. 75 cts.

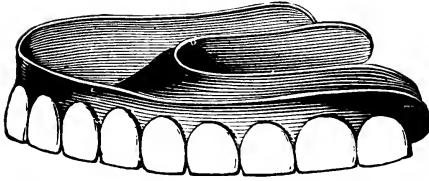

No. 276B. 50 cts.

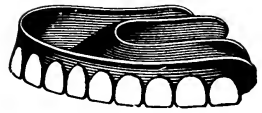

No. 277B. 35 cts.



No. 2695C. 75 cts.



No. 2253D. 80 cts.

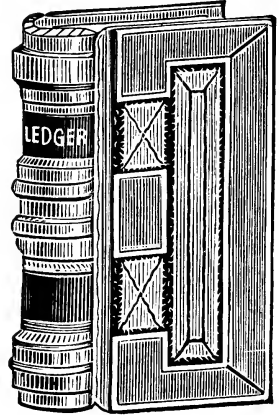

No. 2171C. 50 cts.

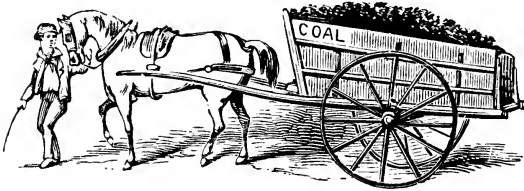

No. 2425C. 40 cts.



No. 4127C. 75 cts.



No. 2356C. 50 cts.



No. 2045E. 50 cts.



No. 3380C. \$1.00

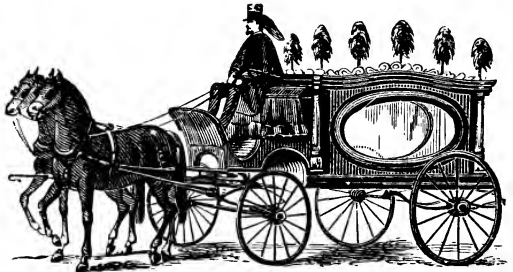

COPPER ALLOY TYPE

No. 2470C. 75 cts.

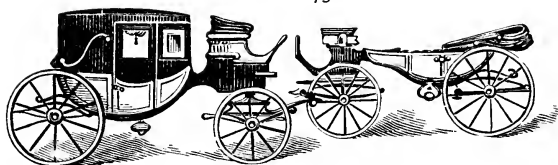

No. 272B. 35 cts.



No. 3471C. 75 cts.

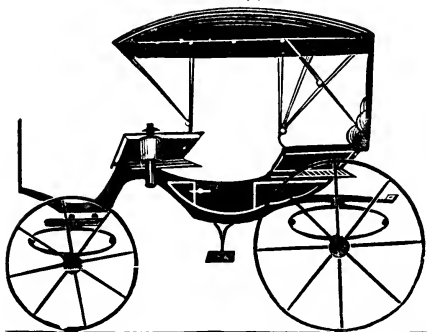

No. 275B. 50 cts

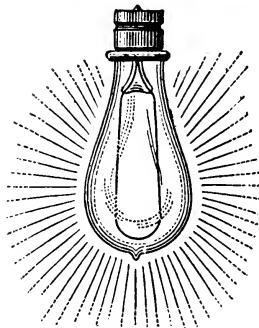

No. 4092C. 75 cts.

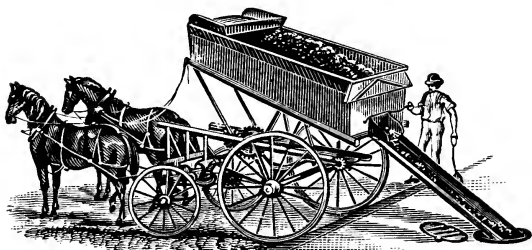

No. 273B. 45 cts.



No. 2898C. Mortised. \$1.25



AMERICAN TYPE FOUNDERS CO.

No. 3204C. 80 cts.

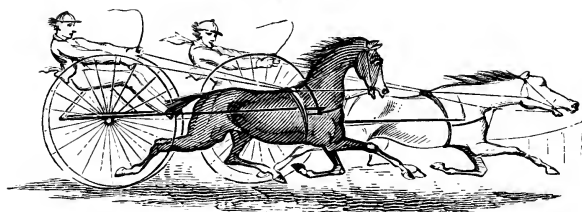

No. 3800C. 30 cts.

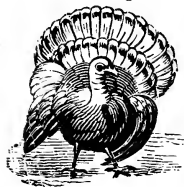

No. 2466C. 50 cts.



No. 3436C. 60 cts.



No. 2050E. \$1.00

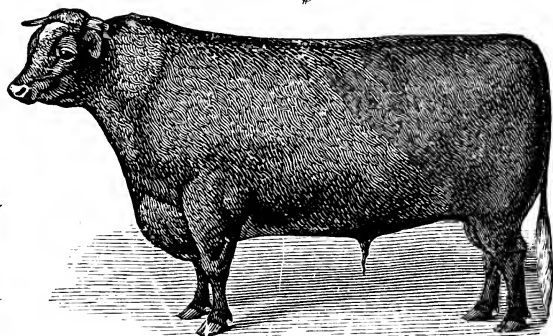

No. 3995C. 60 cts.



No. 3756C. \$1.25

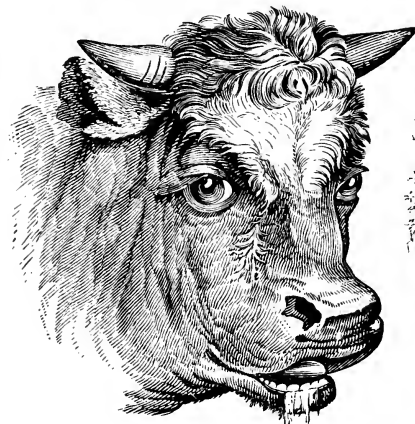

No. 3787C. \$1.25

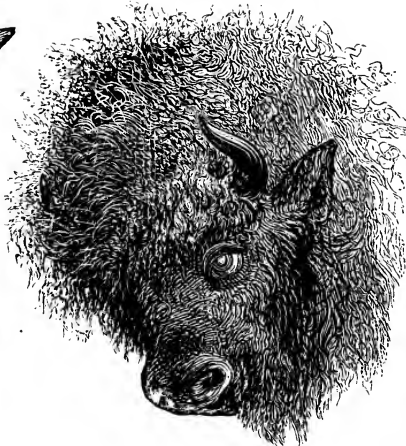

COPPER ALLOY TYPE

No. 2046E. \$1.00

VICTORY



No. 2035C. 50 cts.

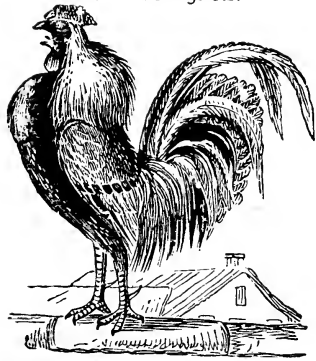

No. 2929C. \$1.00



No. 4099C. \$1.00



No. 2726C. 25 cts.



No. 3055C. 40 cts.



OUTLINE NEWS CUTS

4

PER SET \$5 00

No. 4201C. 50 cts.



BARBER

No. 4202C. 50 cts.

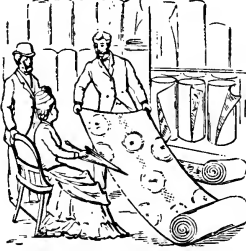

CARPETS

No. 4203C. 50 cts.



DRY GOODS

No. 4204. 50 cts



FURNITURE

No. 4205C. 50 cts.



HATS

No. 4206C. 50 cts.



MILLINERY

No. 4207C. 50 cts.



OPTICIAN

No. 4208C. 50 cts.



OYSTERS

No. 4209C. 50 cts.



PROVISIONS

No. 4210C. 50 cts.



SHOES

No. 4211C. 50 cts.



SHOES

No. 4212C. 50 cts.



TOYS

MENU CUTS

4

No. 4067C. 60 cts.



No. 4055C. 50 cts.



No. 4070C. 60 cts.



No. 4065C. 75 cts.



No. 4068C. 75 cts.



No. 4058C. 75 cts.



INDEX CORNERS

4

*Be careful to add "Index Corners" to the No. wanted*

No. 4049. 50c.

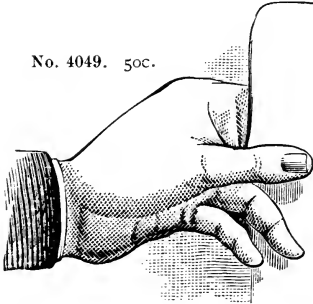

No. 3992. 25c.

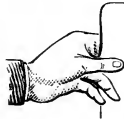

No. 4050. 50c.

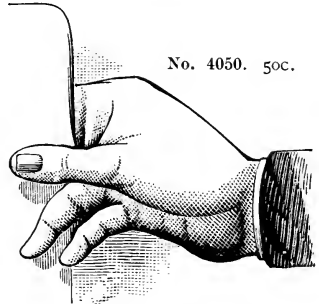

No. 4047. 50c.

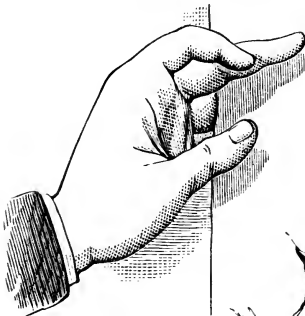

No. 3993. 25c.



No. 4048. 50c.

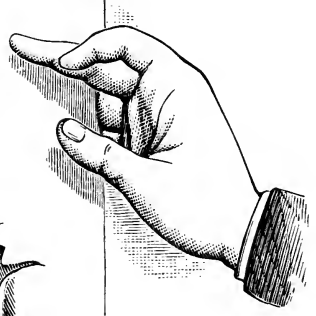

No. 4053. 50c.

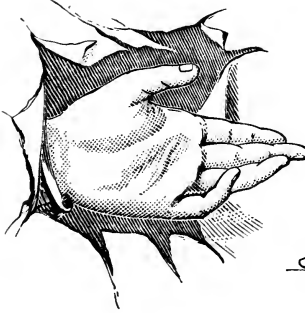

No. 4043. 35c.



No. 4044. 35c.



No. 4051. 50c.

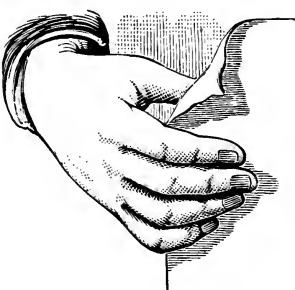

No. 3990. 25c.



No. 4052. 50c.

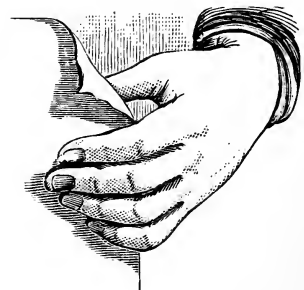

No. 3991. 25c.





COPPER ALLOY TYPE

No. 4175C. Per set, \$2.50 (Same size in Outline, No. 4177C, per set, \$2.50)



No. 4178C. Per set, \$2.00.  
(Same size Shaded, No. 4176C, per set, \$2.00)

No. 4179C. Not Mortised  
Per set, \$1.00



**Electrotyped Outline Figures**

FIRST SERIES. 30 cts. each

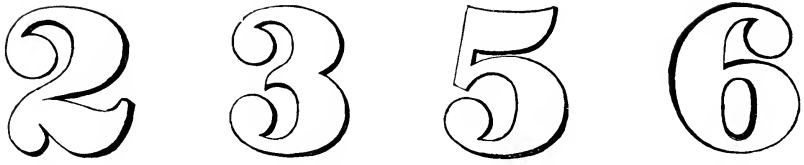

SECOND SERIES. 40 cts. each

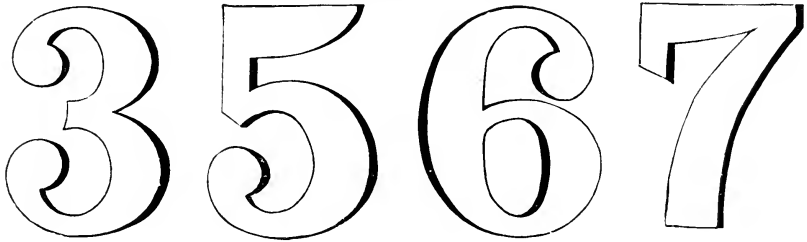

THIRD SERIES. 40 cts. each

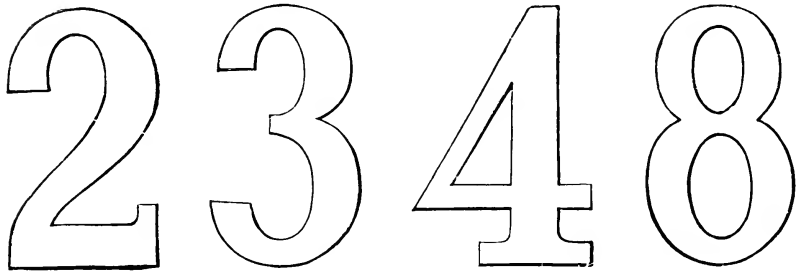

FOURTH SERIES. 50 cts each



# WOOD TYPE

---



The following series are selected from our Complete Specimen Book of Wood Type, which will be forwarded on application. It contains the most up-to-date, and also all the standard styles of Wood Type, Borders and Ornaments.

## SIZES OF FONTS

Wood Type is priced by the letter, and sold in various sized fonts, as under. Orders for less than a font are strictly net; font orders are subject to discount. For schemes of fonts see our Specimen Book of Wood Type.

3A cap font contains 75 letters.

3a lower case font contains 65 letters.

4A cap font contains 106 letters.

4a lower case font contains 90 letters.

5A cap font contains 120 letters.

5a lower case font contains 104 letters.

Figures are put up separately. Each font contains 26 characters, which includes two \$ signs.

---

# American Type Founders Co.

COVERING THE CONTINENT

No. 641 10-LINE

12 CENTS PER LETTER

**C**  
**y**  
**p**  
**e**

No. 641 8-LINE

10 CENTS PER LETTER

**S**  
**e**  
**r**  
**i**  
**e**  
**s**

No. 641 6-LINE

8 CENTS PER LETTER

**B**  
**r**  
**a**  
**d**  
**l**  
**e**  
**y**

For sizes of fonts, see page 753. For other sizes of above series, see our Specimen Book of Wood Type. Sent on application only

NO. 642 10-LINE

10 CENTS PER LETTER

Red

NO. 642 8-LINE

8 CENTS PER LETTER

Boat

NO. 642 6-LINE

6 CENTS PER LETTER

Decent

For sizes of fonts, see page 753. For other sizes of above series, see our Specimen Book of Wood Type. Sent on application only

No. 627 10-LINE

10 CENTS PER LETTER

Sir

No. 627 8-LINE

8 CENTS PER LETTER

Bed

No. 627 6-LINE

6 CENTS PER LETTER

Dime

For sizes of fonts, see page 753. For other sizes of above series, see our Specimen Book of Wood Type. Sent on application only

No. 629 10-LINE

10 CENTS PER LETTER

Goal

No. 629 8-LINE

8 CENTS PER LETTER

Rates

No. 629 6-LINE

6 CENTS PER LETTER

Bards4

For sizes of fonts, see page 753. For other sizes of above series, see our Specimen Book of Wood Type. Sent on application only

NO. 23 10-LINE

10 CENTS PER LETTER

**INS**

NO. 23 8-LINE

8 CENTS PER LETTER

**III**

NO. 23 6-LINE

6 CENTS PER LETTER

**Best 2**

For sizes of fonts, see page 753. For other sizes of above series, see our Specimen Book of Wood Type. Sent on application only



WOOD TYPE SPECIMENS

---

NO. 37 10-LINE

10 CENTS PER LETTER

**RUN**

NO. 37 8-LINE

8 CENTS PER LETTER

**MINE**

NO. 37 6-LINE

6 CENTS PER LETTER

**HORDE**

For sizes of fonts, see page 753. For other sizes of above series, see our Specimen Book of Wood Type. Sent on application only

NO. 69 10-LINE

10 CENTS PER LETTER

**COME**

NO. 69 8-LINE

8 CENTS PER LETTER

**ROCKS**

NO. 69 6-LINE

6 CENTS PER LETTER

**SOSHONE**

For sizes of fonts, see page 753. For other sizes of above series, see our Specimen Book of Wood Type. Sent on application only

WOOD TYPE SPECIMENS

---

No. 24 10-LINE

10 CENTS PER LETTER

**BANDIT**

No. 24 8-LINE

8 CENTS PER LETTER

**GRANDER**

No. 24 6-LINE

6 CENTS PER LETTER

**HORSE BACK**

For sizes of fonts, see page 753. All sizes complete with caps, lower case and figures. For other sizes of above series, see our Specimen Book of Wood Type. Sent on application only

NO. 95 10-LINE

10 CENTS PER LETTER

**BOUNDING**

NO. 95 8-LINE

8 CENTS PER LETTER

**HOUSE DOGS**

NO. 95 6-LINE

6 CENTS PER LETTER

**LEATHER SHOES**

For sizes of fonts, see page 753. All sizes complete with caps, lower case and figures. For other sizes of above series, see our Specimen Book of Wood Type. Sent on application only

NO. 45 10-LINE

9 CENTS PER LETTER

**RUG**

NO. 45 8-LINE

8 CENTS PER LETTER

**BUGS**

NO. 45 6-LINE

6 CENTS PER LETTER

**SNORE**

For sizes of fonts, see page 753. For other sizes of above series, see our Specimen Book of Wood Type. Sent on application only

NO. 71 10-LINE

9 CENTS PER LETTER

**MEG**

NO. 71 8-LINE

8 CENTS PER LETTER

**RENS**

NO. 71 6-LINE

6 CENTS PER LETTER

**SHORN**

For sizes of fonts, see page 753. For other sizes of above series, see our Specimen Book of Wood Type. Sent on application only

No. 50 10-LINE

9 CENTS PER LETTER

**DRUG**

No. 50 8-LINE

8 CENTS PER LETTER

**RIMED**

No. 50 6-LINE

6 CENTS PER LETTER

**ORGANS**

For sizes of fonts, see page 753. For other sizes of above series, see our Specimen Book of Wood Type. Sent on application only

NO. 81. 10-LINE

9 CENTS PER LETTER

**HORNED**

NO. 81 8-LINE

8 CENTS PER LETTER

**WRECKED**

NO. 81 6-LINE

6 CENTS PER LETTER

**HENDERSONS**

For sizes of fonts, see page 753. For other sizes of above series, see our Specimen Book of Wood Type. Sent on application only



WOOD TYPE SPECIMENS

WOOD RULE

12 cents per yard on side-wood ; 15 cents per foot on end-wood—in assorted lengths. End-wood Rule cannot be supplied in yard lengths. Solid corners to match all sizes, 25 cents per set of four. Wood Rule is sold at a lesser discount than Wood Type

STYLE W

24 POINT



STYLE U

18 POINT



STYLE R

12 POINT



STYLE N

8 POINT



STYLE H

18 POINT



STYLE E

12 POINT

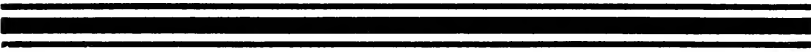

STAR RULE

In fonts of 5 feet, with one set of Corners, \$1.90. Star Rule cannot be supplied in yard lengths

No. 27



No. 23



No. 24



No. 20



For other styles of Wood and Star Rules, see our Complete Specimen Book of Wood Type. Sent on application only

**END-WOOD BORDERS**

Kept in stock in 5-foot fonts, with one set of Corners. For a full sheet 10 feet of Border are required

No. 333

5 FEET WITH CORNERS \$5 40

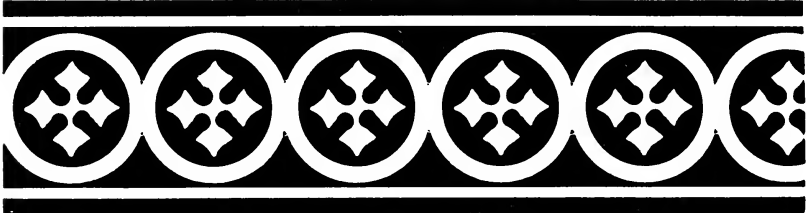

No. 295

5 FEET WITH CORNERS \$4 20



No. 131

5 FEET WITH CORNERS \$4 20



No. 110

5 FEET WITH CORNERS \$4 20



No. 254

5 FEET WITH CORNERS \$3 60



No. 259

5 FEET WITH CORNERS \$3 60



No. 250

5 FEET WITH CORNERS \$3 60



No. 40

5 FEET WITH CORNERS \$3 60



For a very complete assortment of Wood Borders, see our Specimen Book of Wood Type. Sent on application only

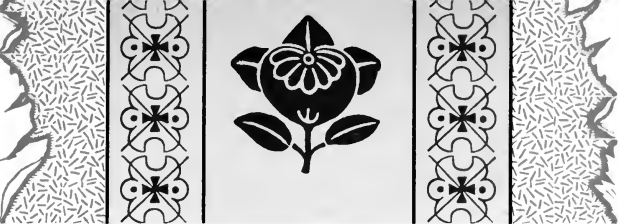

*.. Catalogue and ..  
.... Price List....*

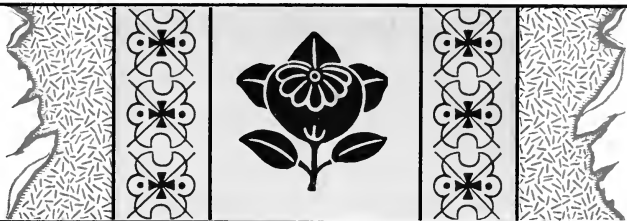

*Everything for  
..the Printer..*



*.. American Type ..  
.. Founders Co. ..*



# Notice to Buyers...

**I**N THIS Section of the Handy Book are shown the best lines of Printing Material and Machinery, covering all the requirements of the printing office.

As the largest buyer in the world of this class of goods, the American Type Founders' Company commands the best in the market at the lowest prices, and is in the best possible position to satisfy its customers.

Buyers of large or small outfits can always get the best money's worth from the American Type Founders' Company. Detailed estimates will be furnished on application to the nearest Branch upon receipt of information concerning the amount to be invested, terms required, and work to be done with such outfits.

# FOR THE COMPOSING ROOM.

## BODKINS.



No. 1, wood handle, needle steel, each . . . . . \$ .10



No. 2, wood handle, needle steel, each . . . . . \$ .10

## TWEEZERS.



This is good and cheap, polished steel, Nonpareil points.

No. 11, nickel-plated, each . . . . . \$ .25



This is the best Tweezer procurable at the price, file point, steel, 4 inches long.

No. 5, nickel-plated, each . . . . . \$ .50



These are the best made, tempered steel, nickel-plated, file-cut points and backs. No. 7 is 4 inches long; No. 8, 4 3/4 inches long.

No. 7, nickel-plated, 4 inches long, each . . . . . \$ .75

No. 8, nickel-plated, 4 3/4 inches long, each . . . . . .85



The only Tweezer that can be carried in the pocket with comfort and safety. It locks and unlocks automatically. Hold

it points down and press between fingers gently, and it unlocks; hold it points up and bring points together, and it locks securely. Patented June 2, 1896.

No. 9. Self-Locking, nickel-plated, each . . . . . \$ .90

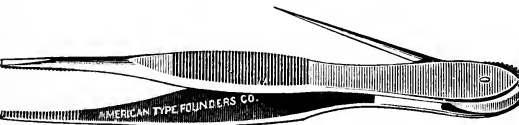

When Tweezer is in use the Bodkin folds into it. When Bodkin is required, pressure on the file-cut arc shown in cut brings it out easily, and when extended it locks securely, and is as firm as an ordinary Bodkin. Patent applied for.

No. 3. Combination Tweezer and Bodkin, nickel-plated, each . . \$1 00

COMPOSING STICKS.

THE BUCKEYE.

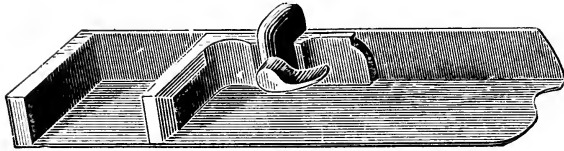

Quick and easy to set; will not slip; lays flat; as secure as the Common Screw Stick, and easier to set than the Yankee Job Stick.

6 ins. × 2, 2¼ or 2½ ins. deep . \$ .90	14 ins. × 2, 2¼ or 2½ ins. deep . \$1.60
8 ins. × 2, 2¼ or 2½ ins. deep . 1.00	16 ins. × 2, 2¼ or 2½ ins. deep . 1.80
10 ins. × 2, 2¼ or 2½ ins. deep . 1.20	20 ins. × 2, 2¼ or 2½ ins. deep . 2.20
12 ins. × 2, 2¼ or 2½ ins. deep . 1.40	24 ins. × 2, 2¼ or 2½ ins. deep . 2.60

YANKEE JOB.

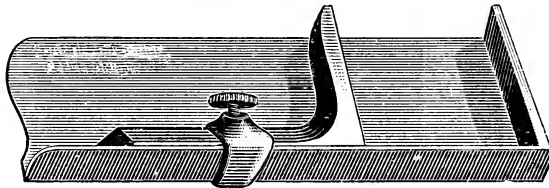

6 ins. × 2, 2¼ or 2½ ins. deep . \$ .75	14 ins. × 2, 2¼ or 2½ ins. deep . \$1.30
8 ins. × 2, 2¼ or 2½ ins. deep . .80	16 ins. × 2, 2¼ or 2½ ins. deep . 1.45
10 ins. × 2, 2¼ or 2½ ins. deep . 1.00	18 ins. × 2, 2¼ or 2½ ins. deep . 1.60
12 ins. × 2, 2¼ or 2½ ins. deep . 1.15	20 ins. × 2, 2¼ or 2½ ins. deep . 1.75

COMMON SCREW.

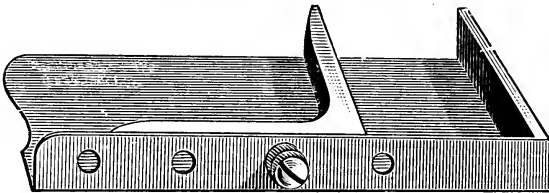

Prices, same as for Yankee Job Composing Sticks (see above).

THE GROVER.

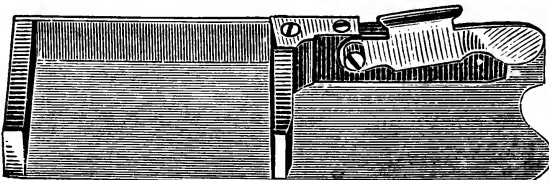

6 × 2¼ inches . . . . . \$ .90	10½ × 2½ inches (billhead) . \$1.60
8 × 2¼ inches . . . . . 1.00	12 × 2¼ inches . . . . . 1.40
10 × 2¼ inches . . . . . 1.20	16 × 2¼ inches . . . . . 1.80

Extra Clasps, 10 cents; extra Knees, 40 cents each.

PERFECT NEWS STICKS.

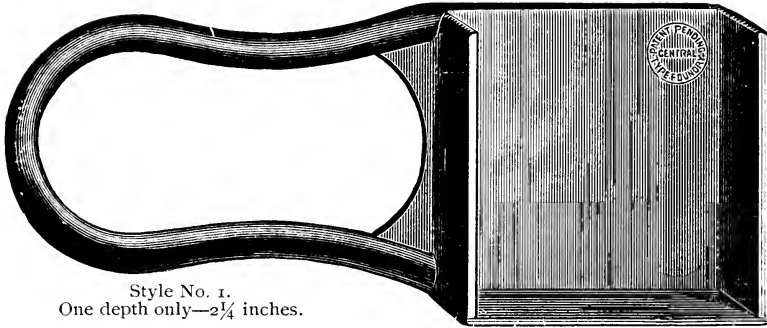

Style No. 1.  
One depth only— $2\frac{1}{4}$  inches.

These Sticks are made for setting one measure only, either 13 or  $13\frac{1}{2}$  ems Pica, and prevent all the annoyances due to variations in Sticks set inaccurately by careless compositors. It is undoubtedly the best Stick made for news measures.

Style No. 1 is made of best malleable iron; the handle and under side are japanned, so that the Stick cannot rust; the pan itself is milled out, the sides being absolutely square and rigid, and altogether the Stick is as perfect as could be desired.

No. 1. Malleable Iron, milled, 13 or  $13\frac{1}{2}$  ems Pica . . . . . \$ .75

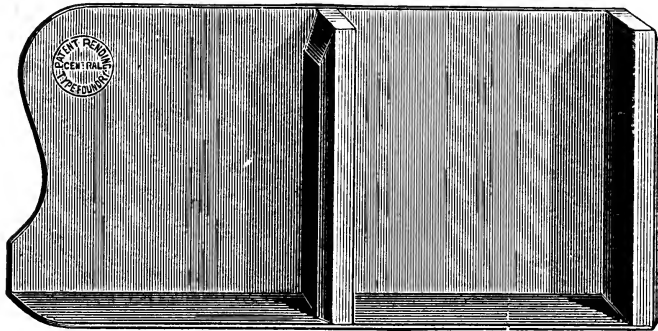

Style No. 2.

Style No. 2 is made of the best of steel, and the set bar or knee is riveted firmly to bottom and back of Stick. It is accurate in every respect.

These Sticks are made for 13 or  $13\frac{1}{2}$  ems Pica a measure, and are  $2\frac{1}{4}$  in. deep.

No. 2. Steel riveted, 13 or  $13\frac{1}{2}$  ems Pica . . . . . \$ .75

“C” SLOT STICK.

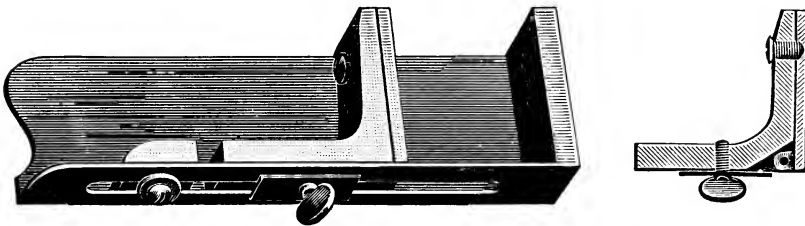

Has two entirely novel features: (1) The inside of face of the knee is adjustable, so that it can be squared up in case the knee wears; (2) The knee is in two sections, so that the Stick can be set to shorter measure without changing the full measure adjustment. See cut, which shows part of the knee at the left set for full measure, while the main part is set to a lesser measure.

6 ins. $\times$ $2\frac{1}{4}$ ins. deep . . . .	\$1.15	10 ins. $\times$ $2\frac{1}{4}$ ins. deep . . . .	\$1.45
8 ins. $\times$ $2\frac{1}{4}$ ins. deep . . . .	1.25	12 ins. $\times$ $2\frac{1}{4}$ ins. deep . . . .	1.65

STANDARD JOB COMPOSING STICK.

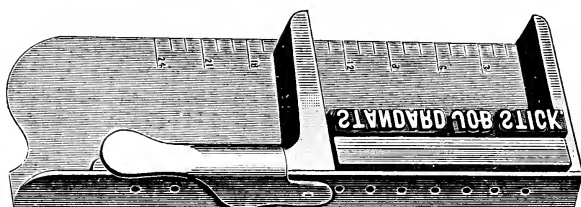

Sets instantly to Nonpareils or Picas, of the point system only, without the use of leads or quads, and once set cannot possibly slip.

	2 ins.	2¼ ins.	2½ ins.		2 ins.	2¼ ins.	2½ ins.
6 inches	\$1.75	\$1.85	\$1.95	10 inches	\$2.25	\$2.35	\$2.45
8 inches	2.00	2.10	2.20	12 inches	2.50	2.60	2.70

WOODEN POSTER STICKS.



With brass-lined ends, iron knee, and screw clamp.

16 inches	\$1.00	30 inches	\$1.35
20 inches	1.10	36 inches	1.50
24 inches	1.20	42 inches	1.80

COMPOSING AND MAKE-UP RULES.



Steel Composing Rules, 15 ems and under, each . . . \$ .25

Add 5 cents to above from 15 to 20 ems, and 10 cents extra from 20 to 25 ems.

Nickel plating, 15 cents extra.

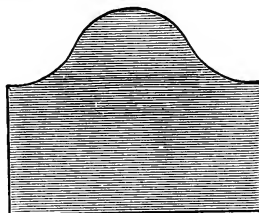

Steel Make-up Rules, 15 ems and under, each . . . \$ .30

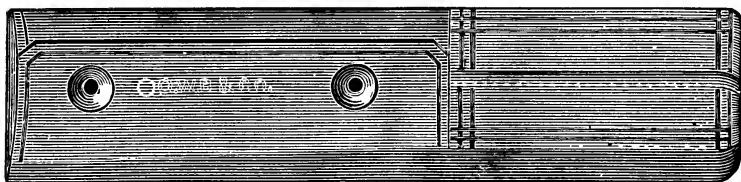

Set of 12 Steel Composing Rules, in leather case . . . \$1.50



**COMPOSING STICK RACK.**

This Rack holds twelve Sticks, and can be attached to the wall or any other convenient place. The Sticks are held securely, and are preserved from the damage liable to them when "kicking about."

Each . . . . . \$1.50

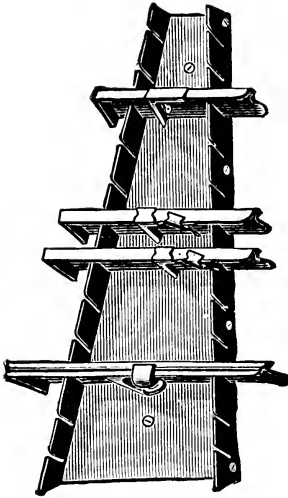

**KELSEY COPY HOLDER.**

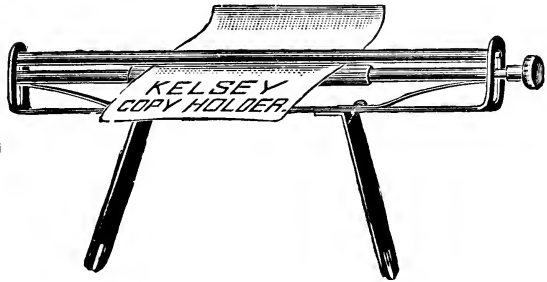

Price, each . . . . . \$ .75

**PAGE CORD.**

The real thing; 8-ply Charter Oak Cotton.

8 oz. balls, each . . . . . \$ .25

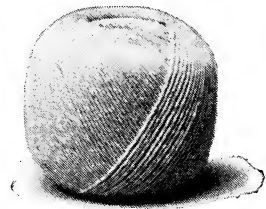

**PRINTER'S EYE SHADE.**

Per dozen . . . . . \$1.50

Each . . . . . .15

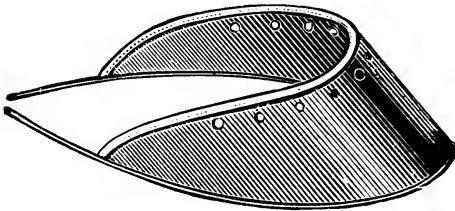

**CHALLENGE LAMP HOLDER.**

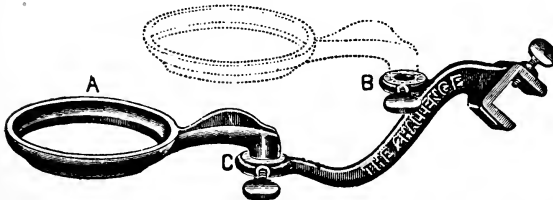

A most convenient and safe attachment for holding a lamp over the compositor's case. It will be readily understood by reference to the cut that the fount holder A can be instantly raised from C to B, as shown by dotted lines, to adapt the position of the light to suit the compositor. Small thumb screws at the top of B and C, with

suitable recesses in A, retain the light perfectly stationary in any position.

Each . . . . . \$ .75

**TYPE MEASURES.**



- Boxwood, triangular shape, the best . . . . . \$1.50
- Patent 12-inch Cardboard Type Scale . . . . . .25
- Lincoln Type Measure, steel tape, in German silver case, 24 inches long, each . . . . . 2.00

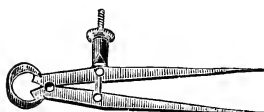

**PRINTER'S DIVIDERS.**

Always useful in laying out margins and distances, imposing plate forms, etc. A great time saver.

Price, each . . . . . \$ .85

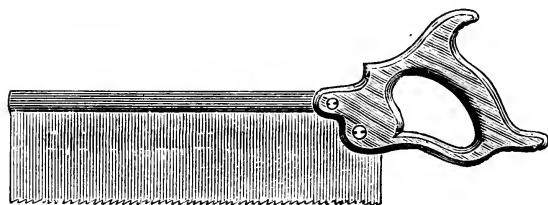

**SAW.**

Back Saw, for cutting wood or metal. . . . . \$1.25

**MITER BOXES.**

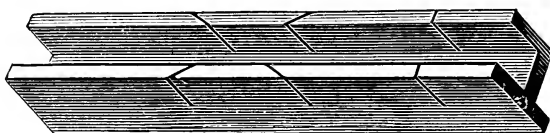

- Wood, 13½ ems wide, each . . . . . \$ .40
- Wood, 3 inches wide, each . . . . . .50
- Iron, each . . . . . 2.50

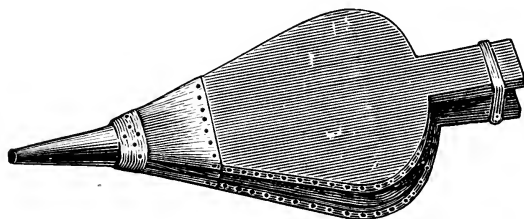

**BELLOWS.**

These Bellows are correct in shape, and strongly made of the best materials.

Small size, each . \$1.00  
Large size, each . 1.25

**LEADER BOXES.**

Just "the thing" for holding leaders. The size is 5 x 8 x 1¾ inches.

Price, per doz . . \$2.50  
Each . . . . . .25

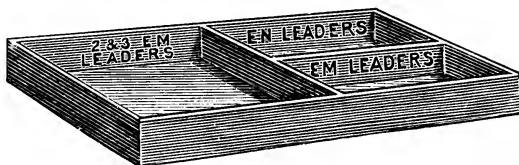

**MALLETS.**

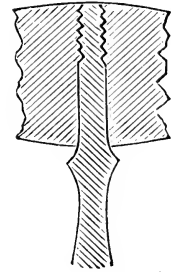
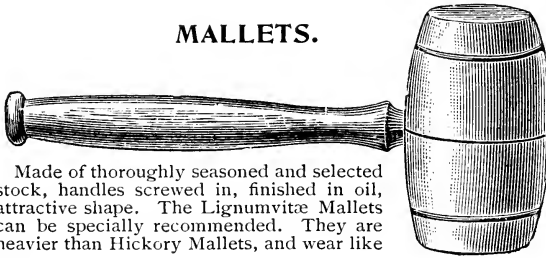

Handle screwed in.

Made of thoroughly seasoned and selected stock, handles screwed in, finished in oil, attractive shape. The Lignumvitae Mallets can be specially recommended. They are heavier than Hickory Mallets, and wear like iron.

Hickory, small, 2½×4½ . . . . .	.25	Lignumvitae, 2¼×3½ . . . . .	\$.50
Hickory, medium, 3 × 5 . . . . .	.30	Lignumvitae, 3 × 5 . . . . .	.60
Hickory, large, 3½×6 . . . . .	.40	Lignumvitae, 3½×5½ . . . . .	.75
<b>Iron Bound</b> . . . . .			1.00

**RAWHIDE-RUBBER MALLET.**

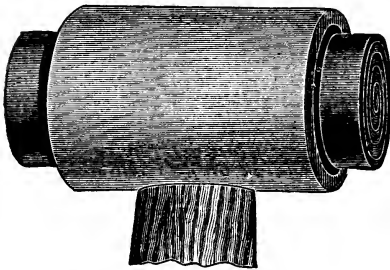

The striking part of mallet is of rawhide, held by an iron band. The iron is covered with rubber as a protection to the type in case the mallet falls on, or is laid on, the form.

Price, each . . . . . \$1.25

**LINOTYPE PLANER.**

The Linotype Planer has a corrugated rubber face and is used for removing the burr from linotype slugs.

Price, each . . . . . \$ .50

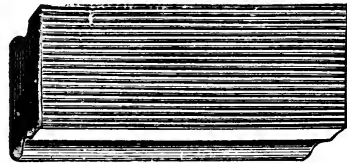

**PLANERS.**

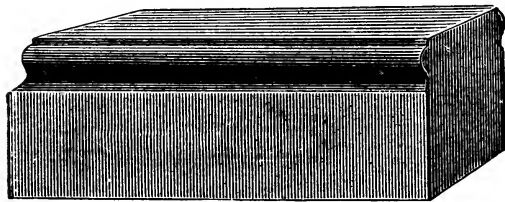

Maple, small, 3×6 . . . . .	\$.25
Maple, large, 3½×8 . . . . .	.30
Maple, leather top, 3½×8 . . . . .	.40

**PROOF PLANERS.**

3½×8 . . . . . .60

**SHOOTING STICKS.**



No. 3, wrought steel, nickel-plated, large, each . . . . .	\$.75
No. 2, wrought steel, nickel-plated, small, each . . . . .	.60



Malleable iron, japanned, each . . . . .	.30
<b>Hickory Shooting Stick</b> , per dozen, 85 cents . . . . . each,	.08

LITTLE GIANT LEAD AND RULE CUTTERS.

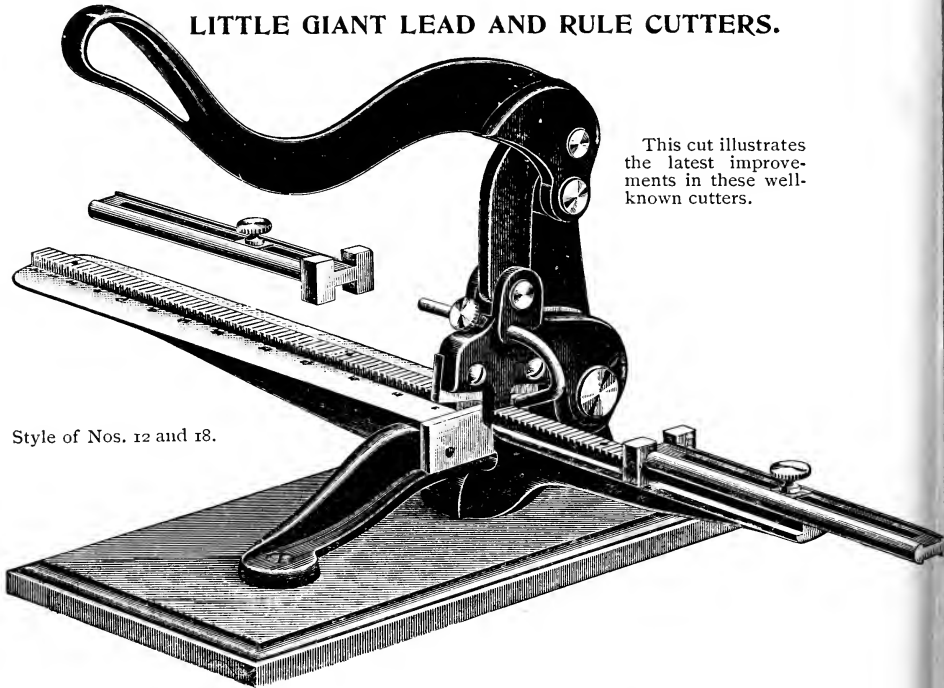

This cut illustrates the latest improvements in these well-known cutters.

Style of Nos. 12 and 18.

Nos. 1 and 3 are the well-known original Little Giants. No. 1 has single, and No. 3 double lever connections. Nos. 12 and 18 have accurate graduated beds and gauges at both front and back of knife, the front gauge being specially designed for cutting leads and rules rapidly, and is so constructed that the cut lead or brass drops off the bed without handling.

No. 1, gauges 12 inches . . . . .	\$8.00
No. 3, gauges 18 inches (extra strong) . . . . .	12.00
No. 12, gauges 12½ inches at back and 11½ inches at front, graduated to Picas . . . . .	10.00
No. 18, gauges 18½ inches at back and 14 inches at front, graduated to Picas . . . . .	14.00

NONPAREIL LEAD CUTTER.

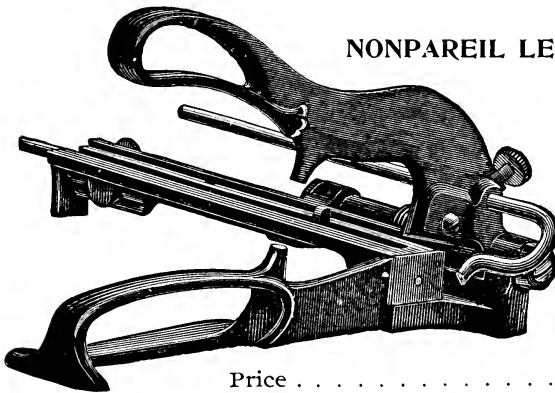

Will cut leads and slugs six points thick, and, although not recommended as a rule cutter, will cut two-point brass rule. Has back and front gauges.

Leads can be cut very rapidly and easily on this cutter by holding the lever and the hand-hold on frame in right hand as in using hand shears.

Price . . . . . \$4.00

**UTILITY  
LEAD CUTTER.**

The strongest cheap lead cutter made. A reliable cheap tool.

Price . . . . \$2.00

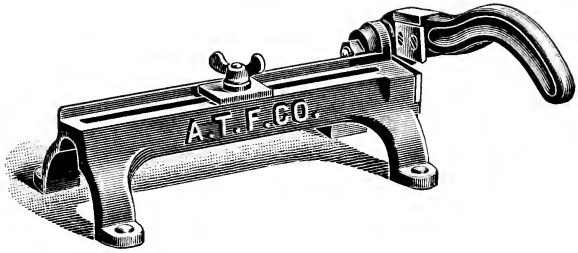

**ELITE RULE BENDER.**

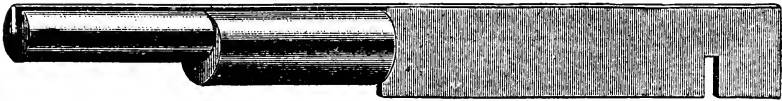

The blade is tool steel and the cylinders of brass. Bends rule from one to six points in thickness. The end of the rule is firmly held in the grooves in cylinder, and can be twisted to any shape.

Price, with instructions for rule bending . . . . . \$2.00

**GRIFFIN HACK SAWS.**

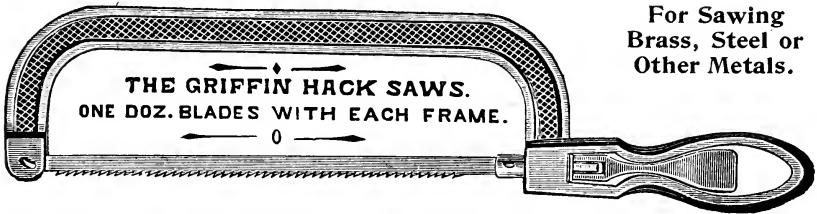

For Sawing  
Brass, Steel or  
Other Metals.

The saw blade is secured to the iron frame by two pins, and may be detached easily. When worn it is cheaper to put in a new blade than to re-file. One dozen extra blades are furnished with each frame. This is a useful tool in any printing office.

Eight-inch Griffin Hack Saw, medium teeth, with one dozen saw blades . . . . . \$2.00



Extra blades, eight-inch, medium teeth, per dozen . . . . . \$1.25

**PLIERS**

For Bending Brass Rule.

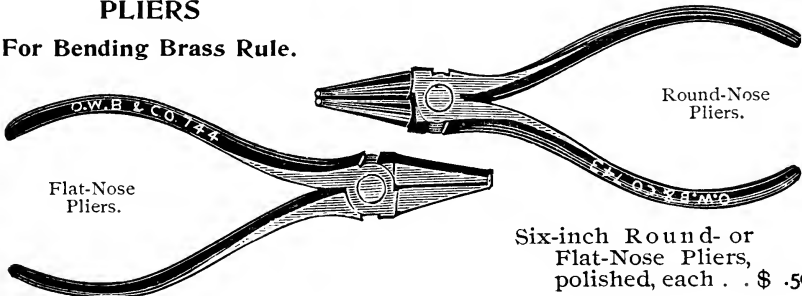

Flat-Nose  
Pliers.

Round-Nose  
Pliers.

Six-inch Round- or  
Flat-Nose Pliers,  
polished, each . . \$ .50

**PATENT UPRIGHT MITER MACHINE.**

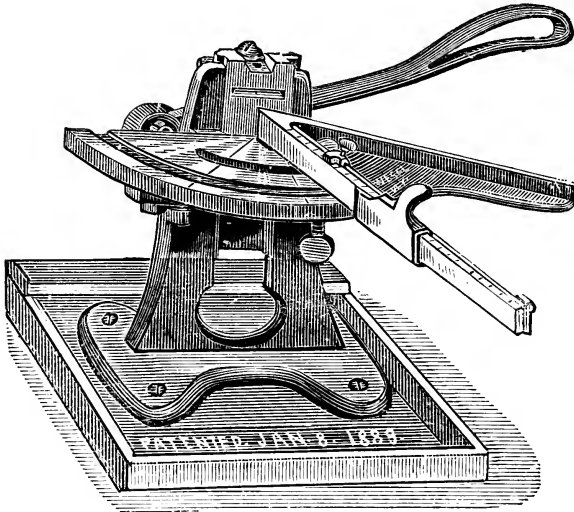

A strong, well-built, accurate machine. The cutting or shaving head has a positive up and down motion, and must cut as much at the bottom as at the top, as it cannot slip. The knife is regulated by set-screw. The sliding gauge is the best of its kind, enabling the operator to feed the rule up to the knife, but affords a positive check at the point where the desired length

is reached. The bed is graduated, and is made movable so that the whole cutting-edge of knife can be used. This machine is mounted in a strong, shallow, wooden box, which catches the shavings, and has at the front end an emery board on which the burr of the rules may be rubbed off.

With Sliding Gauge . . . . . \$13.00  
 With Micrometer Point-System Gauge . . . . . 20.00

**GOLDING UPRIGHT MITERER.**

This machine differs in principle from the Patent Miterer (described on this page) in this: the rule is held stationary, and the knife is fed up to it, while in the Patent Miterer the knife is stationary and the rule is fed to it. The knife of the Golding Miterer is movable, but it is pivoted in such a way as to enable it to make a positive downward cut the same at the bottom as at the top. The knife adjustment is specially good. The bed is graduated, and is made movable so that the whole cutting-edge of the knife may be used.

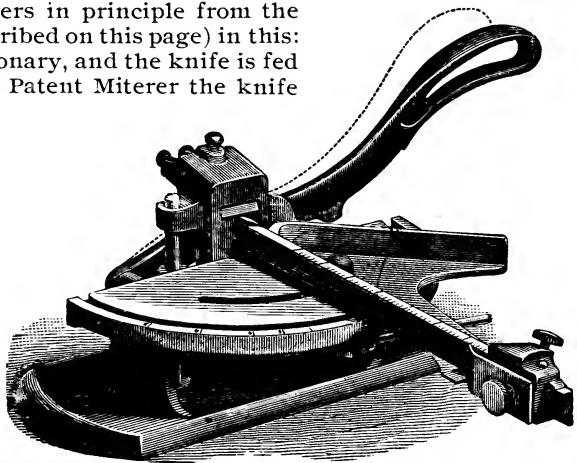

Price, boxed . . . . . \$14.00

**LITTLE GIANT RULE SHAPER.**

The rule is held flat on the bed by the clamp (2). The gauge (5) is graduated to picas by notches, and is regulated by the pointer (4), which engages in the notches. Five steel cutting tools of differing angles are furnished with each machine. The cutting tool is held in the head (1). By turning the wheel the cutter is moved back and forth over the rule, sinking deeper at each cut, and when it completes the cut it is lifted automatically, ready for the next cut. If the rule is thinner than 12 points, the head (1) may be brought down to the rule by moving the lever (3). Any thickness of rule up to 12 point may be mitered. At each cut both sides of the miter are made, and join without further trimming. This machine is not designed for trimming the ends of leads and rules, and therefore does not supersede the upright miterer, but in offices where much mitering is done it will prove a time and rule saver, as it miters very rapidly.

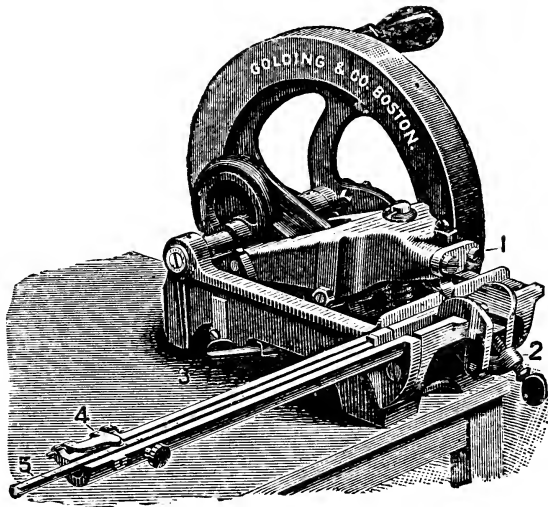

*Send for illustrated circular.*

Price . . . . . \$35.00  
 Patent graduated gauge, extra . . . . . 4.00

**GOLDING RULE CURVING MACHINE.**

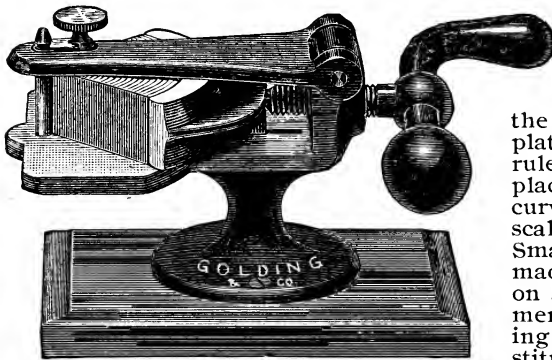

This machine curves brass rule from one-quarter inch to eight inches in diameter by pressure exerted by the screw on curved brass plates, between which the rule is put at the proper place to get the required curve, as indicated by a scale engraved on the bed. Smaller curves can be made on this machine than on any other. An attachment is supplied for forming square corners as a substitute for mitered corners.

Brass rule for curving or bending should be annealed. All brass rule made by us can be annealed to order at a slight extra charge.

No. 1, curves one-quarter to four inches diameter . . . . . \$12.00  
 No. 2, curves three-eighths to eight inches diameter . . . . . 18.00  
 Dies for forming square corners, per set . . . . . 1.50

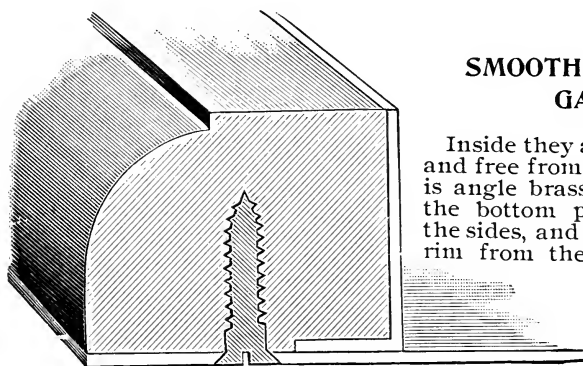

Sectional end view.

**SMOOTH-LINED BRASS GALLEYS.**

Inside they are perfectly smooth and free from screws. The lining is angle brass, and is soldered to the bottom plate, strengthening the sides, and protecting the wood rim from the action of lye and water. The head is supported by a strong strip of brass.

**COLUMN GALLEYS.**

Single Column, brass lined,	$3\frac{1}{2} \times 23\frac{1}{8}$ inches inside	.. . . .	\$2.00
Single Column, brass lined,	$3\frac{1}{2} \times 11\frac{3}{8}$ inches inside	.. . . .	1.50
Medium width, brass lined,	$4\frac{3}{4} \times 23\frac{1}{8}$ inches inside	.. . . .	2.25
Double Column, brass lined,	$6\frac{1}{4} \times 23\frac{1}{8}$ inches inside	.. . . .	2.50
Triple Column, brass lined,	$8\frac{1}{2} \times 23\frac{1}{8}$ inches inside	.. . . .	3.00
Single Column, half lined,	$3\frac{1}{2} \times 23\frac{1}{8}$ inches inside	.. . . .	1.75
Double Column, half lined,	$6\frac{1}{4} \times 23\frac{1}{8}$ inches inside	.. . . .	2.25

**JOB GALLEYS.**

6 × 10 inches inside	.. . . . \$2.00	14 × 20 inches inside	.. . . . \$4.00
$8\frac{3}{4} \times 13$ inches inside	.. . . . 2.50	15 × 22 inches inside	.. . . . 5.00
10 × 16 inches inside	.. . . . 3.00	18 × 25 inches inside	.. . . . 5.75
12 × 18 inches inside	.. . . . 3.50		

**UNLINED GALLEYS.**

**ZINC BOTTOM.**

Single Column, $3\frac{1}{2} \times 23\frac{1}{8}$ inches inside	.. . . . \$1.25
Double Column, $6\frac{1}{4} \times 23\frac{1}{8}$ inches inside	.. . . . 1.50

**BRASS BOTTOM.**

Single Column, $3\frac{1}{2} \times 23\frac{1}{8}$ inches inside	.. . . . \$1.50
Double Column, $6\frac{1}{4} \times 23\frac{1}{8}$ inches inside	.. . . . 2.00

**CLOSED-END MAILING GALLEYS.**

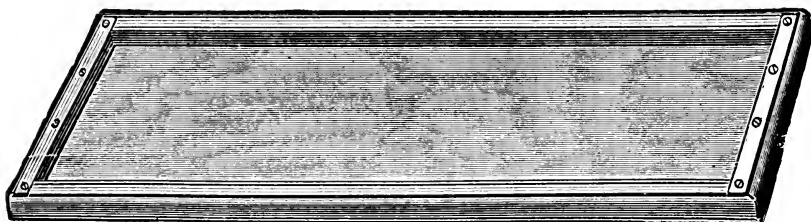

$6\frac{1}{4} \times 23\frac{1}{2}$ inches inside, closed ends, all brass, each	.. . . . \$3.25
$7\frac{1}{4} \times 23\frac{1}{2}$ inches inside, closed ends, all brass, each	.. . . . 3.50
$6\frac{1}{4} \times 22\frac{1}{4}$ inches inside, closed ends, brass lined, each	.. . . . 3.00
10 × $22\frac{1}{4}$ inches inside, closed ends, brass lined, each	.. . . . 4.00
$2\frac{7}{8} \times 24$ inches inside, closed ends, brass lined, each	.. . . . 2.25
$6\frac{1}{4} \times 22\frac{1}{4}$ closed ends, zinc bottom, unlined, each	.. . . . 1.50



**SUCCESS RIVETED ALL-BRASS GALLEYS.**

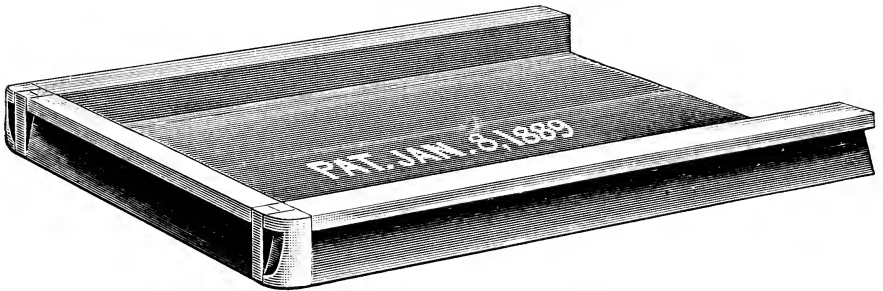

These galleys will be found to be a great improvement over those galleys with bottoms screwed to the sides. The list prices remain the same as charged for galleys with bottoms secured by screws.

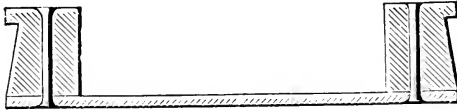

Shows method of securing sides to bottom by rivets.

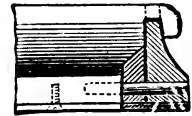

Shows patent corner hold.

**COLUMN ALL-BRASS GALLEYS.**

Single,	$3\frac{3}{4} \times 23\frac{3}{4}$	inches inside	.....	\$2.00
Single,	$3\frac{3}{4} \times 11\frac{3}{4}$	inches inside	.....	1.50
Medium,	$5 \times 23\frac{3}{4}$	inches inside	.....	2.25
Double,	$6\frac{1}{4} \times 23\frac{3}{4}$	inches inside	.....	2.50
Triple,	$8\frac{1}{4} \times 23\frac{3}{4}$	inches inside	.....	3.25

**JOB ALL-BRASS GALLEYS.**

6 × 10 ins. inside	.....	\$1 50	12 × 18 ins. inside	.....	\$3.75
$8\frac{3}{4} \times 13$ ins. inside	.....	2 00	14 × 21 ins. inside	.....	4.50
9 × 14 ins. inside	.....	2 50	15 × 22 ins. inside	.....	5.00
10 × 16 ins. inside	.....	3 00	18 × 25 ins. inside	.....	6.00

**MAILING GALLEYS.**



Mustang Mailing Galley.

Mustang Mailing Galley, zinc bottom	.....	\$ .50
Mustang Mailing Galley, brass bottom	.....	.75

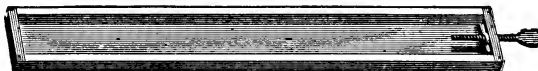

Rukenbrod Mailing Galley.

Rukenbrod Mailing Galley, zinc bottom	.....	\$ .60
Rukenbrod Mailing Galley, brass bottom	.....	.85

**LAING PATENT GALLEY LOCK-UP.**

**Attachable to Any Kind  
or Style of Galley.\***

A satisfactory, simple, effective lock-up. It may be screwed on any galley; the side stick (which is not beveled) is attached to the lock-up, and has a parallel motion. It is locked or unlocked by pushing the lever up or down by means of a finger knob. The lock-up and the side stick are made of brass.

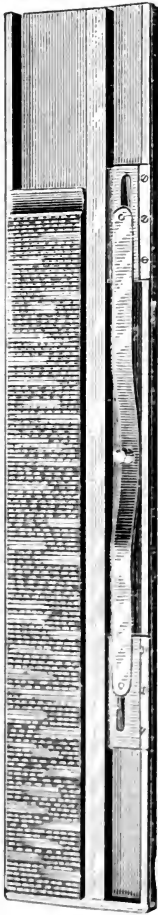

**\*COLUMN GALLEYS, WITH LOCK-UP.**

	Price of Galley.	*Price of Lock- up.	Com- plete.
3 $\frac{3}{4}$ × 23 $\frac{3}{4}$ inches inside . . . . .	\$2.00	\$1.50	\$3.50
3 $\frac{3}{4}$ × 15 $\frac{3}{4}$ inches inside . . . . .	1.75	1.40	3.15
3 $\frac{3}{4}$ × 11 $\frac{3}{4}$ inches inside . . . . .	1.50	1.30	2.80
5 × 23 $\frac{3}{4}$ inches inside . . . . .	2.25	1.50	3.75
6 $\frac{1}{4}$ × 23 $\frac{3}{4}$ inches inside . . . . .	2.50	1.50	4.00
6 $\frac{1}{4}$ × 15 $\frac{3}{4}$ inches inside . . . . .	2.25	1.40	3.65
6 $\frac{1}{4}$ × 11 $\frac{3}{4}$ inches inside . . . . .	2.00	1.30	3.30
8 $\frac{1}{4}$ × 23 $\frac{3}{4}$ inches inside . . . . .	3.25	1.50	4.75

**\*JOB GALLEYS, WITH LOCK-UP**

	Price of Galley.	*Price of Lock- up.	Com- plete.
6 × 10 inches inside . . . . .	\$1.50	\$1.25	\$2.75
8 $\frac{3}{4}$ × 13 inches inside . . . . .	2.00	1.30	3.30
9 × 14 inches inside . . . . .	2.50	1.35	3.85
10 × 16 inches inside . . . . .	3.00	1.40	4.40
12 × 18 inches inside . . . . .	3.75	1.45	5.20
14 × 21 inches inside . . . . .	4.50	1.50	6.00
15 × 22 inches inside . . . . .	5.00	1.50	6.50
18 × 25 inches inside . . . . .	6.00	1.60	7.60

\* If Galley Lock-up is sold separately, the necessary screws for attaching to galley are included in prices given.

**WOODEN GALLEYS.**



5 × 8 in. inside . . . . .	\$ .25
5 × 15 in. inside . . . . .	.30
5 $\frac{1}{2}$ × 18 in. inside . . . . .	.40
6 × 10 in. inside . . . . .	.30
6 $\frac{1}{2}$ × 24 in. inside . . . . .	.60
7 × 22 in. inside . . . . .	.55
8 × 10 in. inside . . . . .	.40
8 × 24 in. inside . . . . .	.60
10 × 16 in. inside . . . . .	.65
9 × 18 in. inside . . . . .	.70
10 × 24 in. inside . . . . .	.75
3 $\frac{1}{2}$ × 24 in. inside . . . . .	.50

LINCOLN ALL-BRASS GALLEYS.

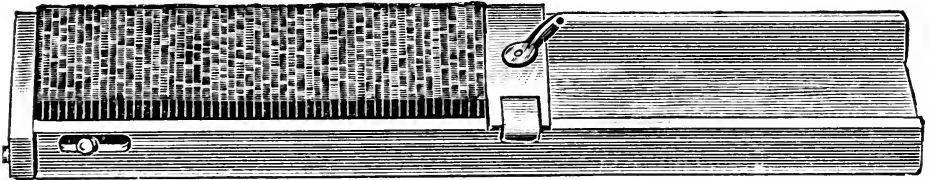

Shows the Galley locked at end and side.

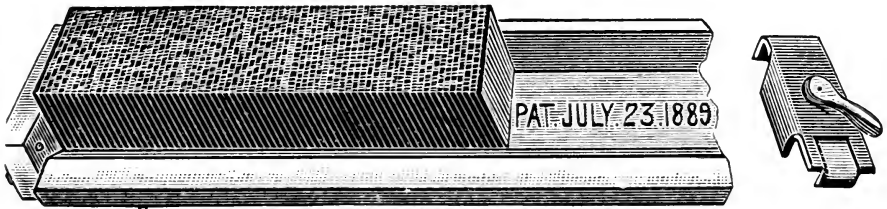

Shows the Galley unlocked, with end lock detached.

A good galley for newspaper work. *Made to order* to hold any regular widths of matter in regular use in an office. The upper side or rim of galley is strongly hinged to the bottom. This hinged side is dropped when emptying on galley, and when matter is ready for locking up the side is raised and is held by a spring-catch at head of galley, and by the end clamp which locks the sides and end at the same operation. The catch is loosened by turning lever to the right. These galleys are about one inch wider than the width of column they are made to take.

12-inch News, all brass . . . \$2.00    24-inch News, all brass . . . \$3 00  
 16-inch News, all brass . . . 2.50    24-inch Book, all brass . . . 3.50

In ordering, give exact width of columns.

PATENT LINOTYPE GALLEY.

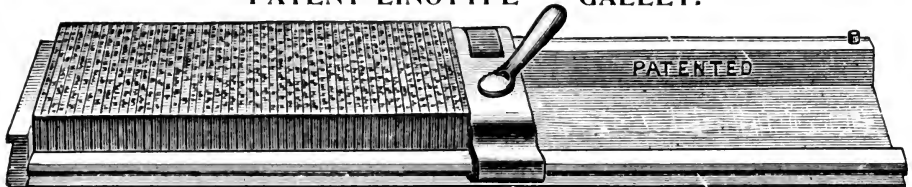

This new patent galley is made solely for linotypes, and is the only galley for holding linotype slugs without any side lock-up. A foot clamp is attached to each galley to hold up the matter in taking proofs. This galley will save all the trouble and the loss of time in handling side-sticks, getting quoins to fit, or foot slugs to keep the end line from falling over. One side of the galley is made lower, and the inside of the rims so tapered as to allow inserting and taking out the linotype slugs from the side very readily. The galley, being only one-half of an inch wider than the matter, is handled and can be placed on the stone, rack or case without taking up valuable space.

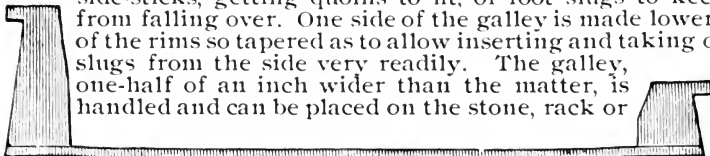

End view, 13 ems wide inside.

12 inch, all-brass News Galley, for 16 ems or under\* . . . . . \$2.00  
 16 inch, all-brass News Galley, for 16 ems or under . . . . . 2.25  
 24 inch, all-brass News Galley, for 16 ems or under . . . . . 2.50  
 Extra foot clamps, each . . . . . .50

Other sizes made to order. Above prices include foot clamp.

\*In ordering, give the measure of column width, as galleys are supplied to take one measure only, not exceeding 16 ems; also send a sample linotype slug.

MOVABLE GALLEY RACKS.

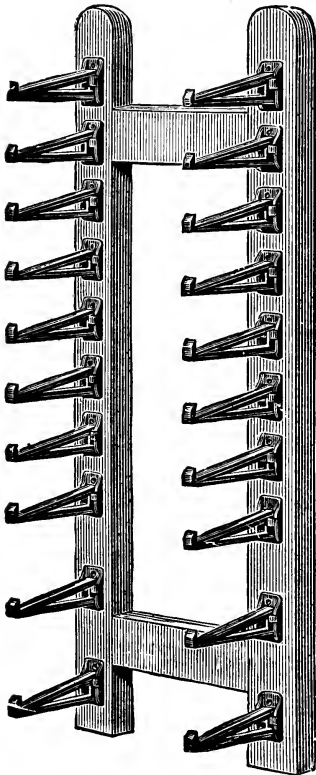

Regular Galley Rack  
with Movable Galley Brackets.

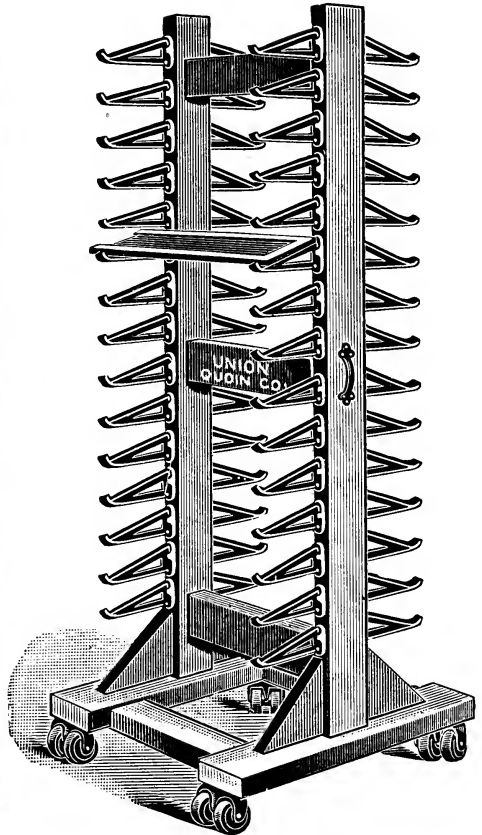

Union Movable Galley Rack.

UNION MOVABLE GALLEY RACK.

The Union Movable Galley Rack holds 30 galleys, and is mounted on strong casters so that it can be moved at will to the most convenient position for doing the work in hand.

Union Movable Galley Rack, holds 30 galleys . . . . . \$21.00

REGULAR GALLEY RACK.

The Regular Galley Rack is intended for placing against the wall. The brackets are secured on a very strong hard-wood frame.

Regular Galley Rack, for 6 galleys . . . . .	3.00
Regular Galley Rack, for 8 galleys . . . . .	4.00
Regular Galley Rack, for 10 galleys . . . . .	5.00
Regular Galley Rack, for 12 galleys . . . . .	6.00
Regular Galley Rack, for 15 galleys . . . . .	7.50
Regular Galley Rack, for 20 galleys . . . . .	10.00

For Galley Brackets, see page 821.

**GALLEY CABINETS.**

Particular attention is directed to the Galley Cabinets of larger capacity. They are very desirable in the larger offices, and are designed to carry an immense weight of type safely. All these cabinets are made of hard wood. All flat-top cabinets are made same style as the 1-Tier Cabinet illustrated below; all galley-top cabinets same as the 3-Tier Cabinet shown on this page.

The "Galley-top" Cabinets are of much stronger construction than the "Flat-top," and may be ordered with or without galley top, as desired, at the same prices.

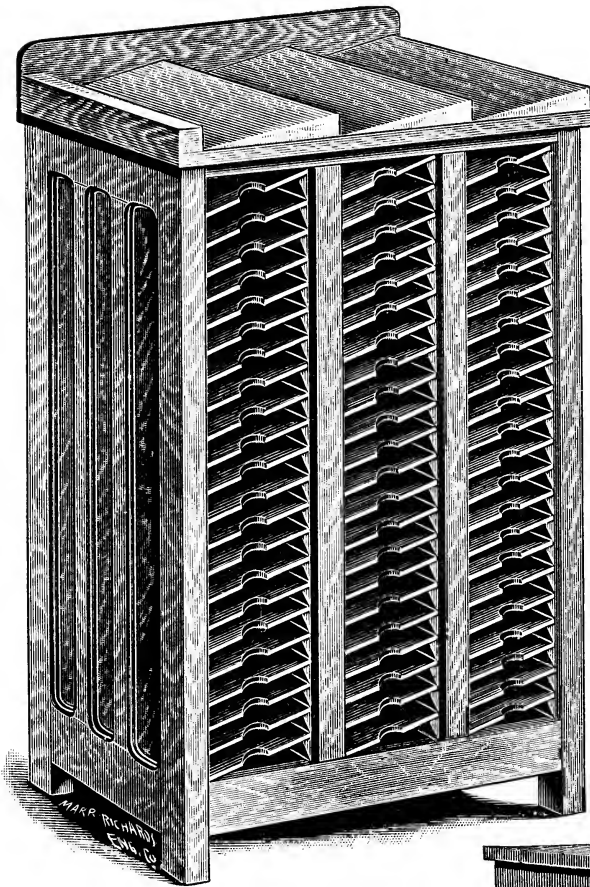

Three-tier Galley Cabinet with Galley Top, to hold Sixty-six Gallies.

**Prices.**

	Galleys held.	With Flat Top.	With Galley Top.	Boxing.
1 Tier,	20	\$ 8.00	\$14.00	\$ .50
1 Tier,	30	11.50	. . .	.75
2 Tier,	40	15.00	25.00	1.00
2 Tier,	50	18.50	. . .	1.25
2 Tier,	60	22.00	. . .	1.50
3 Tier,	66	. . .	36.00	2.00
4 Tier,	88	. . .	47.50	2.50
6 Tier,	132	. . .	62.00	3.00
9 Tier,	198	. . .	85.00	4.00

NOTE.—The shelves in the larger cabinets should be numbered, and the proof of the galley should be numbered to correspond with the number on shelf, thus saving all the time required to locate galleys that are not so numbered. Iron number plates, made for numbering shelves, can be supplied at the following prices, net: 1 tier (20 galleys), \$1.00; 1 tier (30 galleys), \$1.25; 2 tiers (40 galleys), \$1.50; 2 tiers (50 galleys), \$1.75; 2 tiers (60 galleys), \$2.00; 3 tiers, \$2.25; 4 tiers, \$3.00; 6 tiers, \$4.00; 9 tiers, \$5.00.

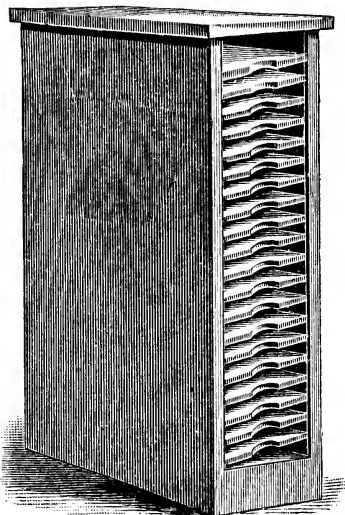

One-tier Flat-Top Galley Cabinet, to hold Twenty Gallies.

**HEMPEL IMPROVED QUOIN.**

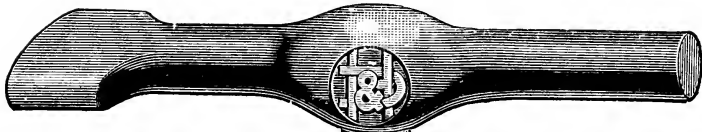

No. 1, small, per dozen  
pairs . . . . . \$2.50  
No. 2, large, per dozen  
pairs . . . . . 3.00  
Keys, each . . . . . .50

The Hempel Quoins are the standard, tested by time, and approved by those who use them. This is the latest improved quoin, made by the original inventor.

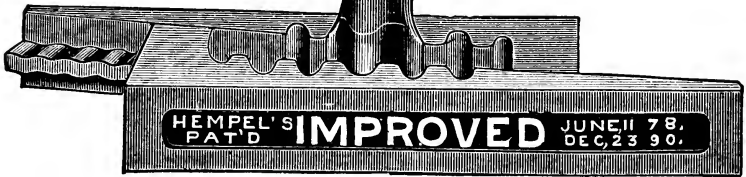

**IMPROVED BROWER QUOIN.**

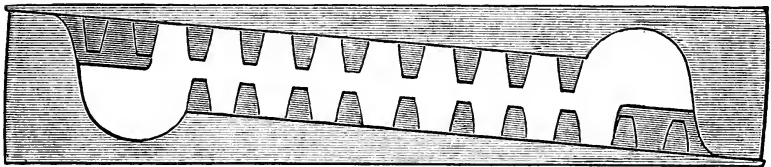

No. 2. Large Size Brower Quoin, 4 in. long.

Has central racks and consequently will not throw type off its feet. Works smoothly. The key, of steel, with cut teeth, has a firmer and deeper hold than in the old style quoin.



No. O. "Little Samson," actual size.

The No. O, as illustrated, is the smallest wedge quoin ever made, and will prove very valuable for job printers and on occasions when lock-up must be made in small spaces.

No. o, smallest wedge quoin ever made, "Little Samson," per  
dozen . . . . . \$2.00  
No. 1, medium size, per dozen . . . . . 2.50  
No. 2, large size, per dozen . . . . . 3.00  
Steel keys, all sizes, each . . . . . .50

	Per Dozen.	Key.
<b>WICKERSHAM QUOIN</b> . . . . .	\$2.50	\$ .50
<b>PERRY QUOIN</b> . . . . .	2.50	.50
<b>CHALLENGE HEMPEL QUOIN, No. 1,</b> . . . . .	2.50	.50
<b>CHALLENGE HEMPEL QUOIN, No. 2,</b> . . . . .	3.00	.50

UNION LOCKABLE QUOIN.

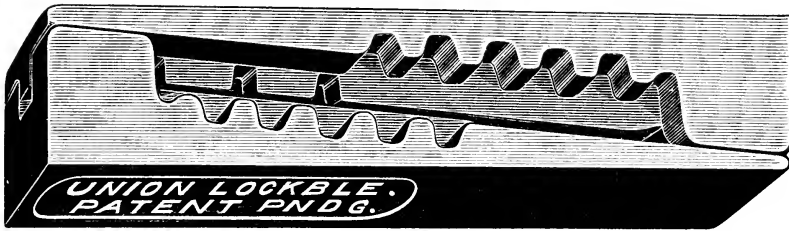

An exact duplicate of the original Hempel Quoin, with three notches cut in the central rib for the purpose of using the quoin in connection with the Patent Brower Lock, listed below.

No. 1, small, per dozen . . . . .	\$2.50
No. 2, large, per dozen . . . . .	3.00
Keys, each . . . . .	.50

BROWER QUOIN LOCK.

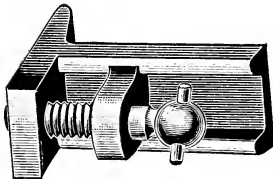

Fig. 2. The Lock.

The sidewise projection shown in Fig. 2 engages in notches cut in central rib of Union Lockable Quoin, or in the rack teeth of the Brower Quoin (see above). The screw is then set up against the other half of the quoin, effectually preventing it from slipping. Quoins of the wedge principle are all liable, on long runs, to be loosened by the vibrations of the press. These locks make the lock-up doubly sure. They should be applied by the pressman after he has completed the make-ready and before the run is commenced.

No. 0, to fit No. 0 Brower Quoin, per dozen . . . . .	\$2.50
No. 1, to fit No. 1 Brower Quoin, per dozen . . . . .	2.75
No. 2, to fit No. 2 Brower Quoin, per dozen . . . . .	3.00
No. 3, to fit No. 1 Union Lockable Quoin, per dozen . . . . .	2.75
No. 4, to fit No. 2 Union Lockable Quoin, per dozen . . . . .	3.00
Screw-driver, to fasten quoin lock, each . . . . .	.50

MIDGET SAFETY QUOIN.



Fig. 2.—This cut shows extreme expansion of six points when locked.

It is locked by a tap of a mallet, and occupies no more space in length when locked than when unlocked.

Can be used in a space 18 points wide by 120 points long, either outside or inside a form. It is absolutely safe, as when locked it rests against its corresponding flat surfaces, and the harder the surface it bears against the better.

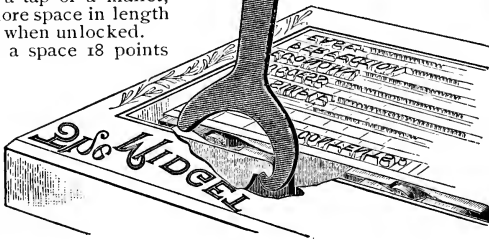
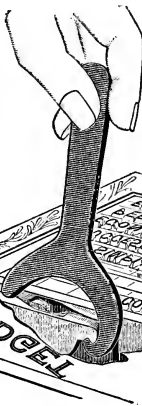

Fig. 1 illustrates the method of unlocking.

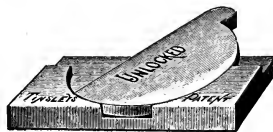

Fig. 3 shows Midget Quoin un-locked.

This invaluable quoin may be used to lock up matter inside a brass circle or oval, or within a solid border, or in places where no other quoin of wood or metal can be used.

Midget Quoins are made of hard brass.

Price, per dozen, with key, net . . . . .	\$2.00
---	--------

WROUGHT IRON CHASES.

**IMPORTANT.**—Other sizes made at approximate prices. In ordering, great care must be exercised to send the correct measurements, as all chases are made to order and cannot be taken back. In ordering, state (1) kind of chase required; (2) inside dimensions of each chase; (3) outside dimensions of each chase, or, in case of twin chases, the pair taken together; (4) if twin chases, give width of backs; (5) width of cross-bars, if any; (6) dimensions of bed of press on which chases are to be used.

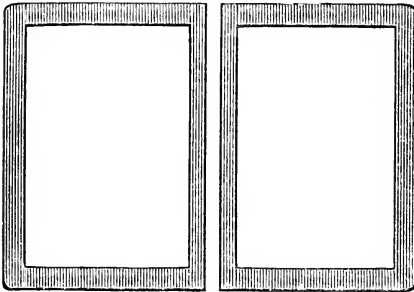

Folio or Twin Chases.

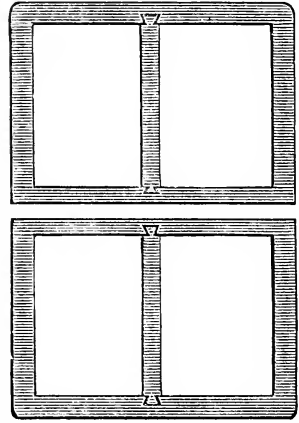

Quarto or Twin Chases with Bars.

FOLIO OR TWIN CHASES.

	Outside Measure, each half.	Price, per Pair.
5-Column Folio . . . . .	14 × 21 <sup>3</sup> / <sub>4</sub> inches . . .	\$ 9.50
6-Column Folio . . . . .	16 <sup>1</sup> / <sub>4</sub> × 24 inches . . .	10.00
7-Column Folio . . . . .	19 × 25 <sup>3</sup> / <sub>4</sub> inches . . .	11.00
7-Column Folio wide . . . . .	20 <sup>1</sup> / <sub>2</sub> × 27 inches . . .	12.00
8-Column Folio . . . . .	21 × 28 inches . . .	13.00
8-Column Folio wide . . . . .	22 <sup>3</sup> / <sub>4</sub> × 29 inches . . .	14.00
9-Column Folio . . . . .	23 <sup>1</sup> / <sub>2</sub> × 30 <sup>1</sup> / <sub>2</sub> inches . . .	15.00
9-Column Folio wide . . . . .	23 <sup>1</sup> / <sub>2</sub> × 32 inches . . .	16.50
10-Column Folio extra . . . . .	25 <sup>1</sup> / <sub>2</sub> × 37 <sup>1</sup> / <sub>2</sub> inches . . .	17.50

QUARTO OR TWIN CHASES WITH BARS.

	Outside Measure, each half.	Price, per Pair.
4-Column Quarto . . . . .	18 × 24 <sup>1</sup> / <sub>2</sub> inches . . .	\$14.50
5-Column Quarto . . . . .	21 <sup>1</sup> / <sub>2</sub> × 28 <sup>1</sup> / <sub>2</sub> inches . . .	15.50
6-Column Quarto . . . . .	23 <sup>3</sup> / <sub>4</sub> × 32 <sup>1</sup> / <sub>2</sub> inches . . .	16.00
7-Column Quarto . . . . .	25 <sup>1</sup> / <sub>2</sub> × 37 <sup>1</sup> / <sub>2</sub> inches . . .	17.50
8-Column Quarto . . . . .	28 × 42 inches . . .	19.50

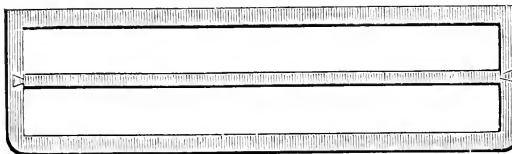

Heading Chase.

HEADING CHASES,  
WITH CROSS-BAR.

Size Inside.	Price.
6 × 17, Flat Cap . . .	\$5.50
8 × 21, Demy . . .	6.00
8 × 28, Double Cap. . .	8.00

These chases also made with short cross-bars upon special order.



EVERYTHING FOR THE PRINTER

**QUADRUPLEX CHASES.**

	Size Outside, each.	Prices per Set of Four.
5-Column . . . . .	14 × 21¼	\$19.00
6-Column . . . . .	16¼ × 23½	20.00
7-Column . . . . .	19 × 25¼	22.00

*Other sizes made to order.*

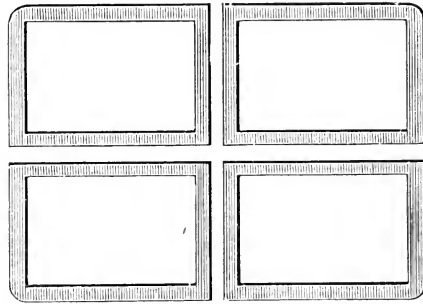

Quadruplex Chases.

**BOOK CHASES.**

Outside Measure.	Price, each.
17×21 inches . . . . .	\$ 8.00
20×25 inches . . . . .	8.50
24×30 inches . . . . .	9.00
25×35 inches . . . . .	9.50
29×42 inches . . . . .	10.00
32×46 inches . . . . .	11.00
34×50 inches . . . . .	12.00
36×52 inches . . . . .	13.00
40×54 inches . . . . .	14.00
42×60 inches . . . . .	15.00

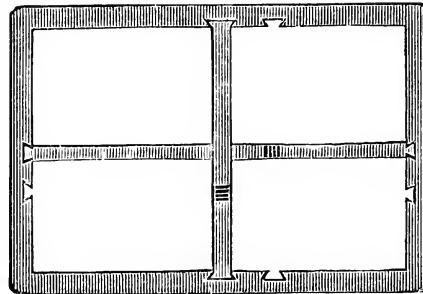

Book Chase.

**SKELETON OR POSTER CHASES.**

Outside Measure.	Price, each.
17×21 inches . . . . .	\$ 4.50
20×25 inches . . . . .	5.50
24×30 inches . . . . .	6.00
25×35 inches . . . . .	6.50
29×42 inches . . . . .	7.25
32×46 inches . . . . .	8.00
34×50 inches . . . . .	9.00
36×52 inches . . . . .	10.00
40×54 inches . . . . .	11.00
42×60 inches . . . . .	12.00

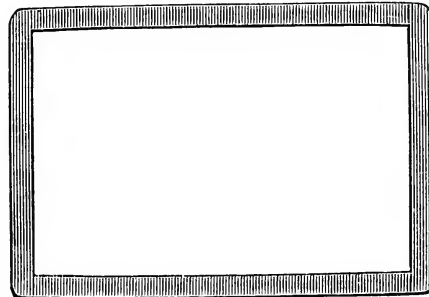

Skeleton or Poster Chase.

**WROUGHT IRON CHASES FOR JOB PRESSES.**

Made to order only.

Eighth Medium, each . . . . .	\$4.25
Quarto Medium, each . . . . .	5.50
Half Medium, each . . . . .	6.50
Half Super-Royal, each . . . . .	7.25

**ELECTROTYPE CHASES.**

These have reinforced corners.

Inside.	Rim.	Cast Iron.	Wrought Iron.
10×14 inches . . . . .	¾ × 1¾ inches . . . . .	\$1.75 . . . . .	\$3.75
12×18 inches . . . . .	¾ × 1¾ inches . . . . .	2.00 . . . . .	4.00

AMERICAN TYPE FOUNDERS CO.

**CAST IRON CHASES.**

Outside Measure.	These are finished inside.	Price.
6 × 7 inches . . . . .		\$ .45
6½ × 8¼ inches . . . . .		.50
6 × 18 inches . . . . .		1.20
8 × 10 inches . . . . .		.80
9 × 12 inches . . . . .		1.00
8½ × 14 inches . . . . .		1.10
8 × 20 inches . . . . .		1.30
8 × 24 inches . . . . .		1.40
8 × 28 inches . . . . .		1.60
10 × 14 inches . . . . .		1.20
10 × 24 inches . . . . .		1.50
10 × 25½ inches . . . . .		1.65
10 × 28 inches . . . . .		1.75
11 × 16 inches . . . . .		1.30
10½ × 14½ inches . . . . .		1.25
12 × 14 inches . . . . .		1.20
12 × 15 inches . . . . .		1.30
12 × 18 inches . . . . .		1.40
12 × 26 inches . . . . .		1.80
12 × 30 inches . . . . .		1.90
12 × 33 inches . . . . .		2.25
13¾ × 20½ inches . . . . .		1.75
14 × 16 inches . . . . .		1.40
14 × 18 inches . . . . .		1.75
14¾ × 19¼ inches . . . . .		1.80
15 × 24 inches . . . . .		2.00
16 × 19 inches . . . . .		1.90
17 × 22 inches . . . . .		1.75
17 × 22 inches, with cross bar . . . . .		2.25

**CHASES FOR C. & P. GORDON PRESSES.**

Size.	Cast Iron.	Cast Iron Screw.	Steel.	Steel Screw.
7 × 11 inches . . . . .	\$1.00	\$1.50	\$2.70	\$4.00
8 × 12 inches . . . . .	1.25	1.90	3.00	4.50
10 × 15 inches . . . . .	1.50	2.25	4.50	6.75
12 × 18 inches . . . . .	2.00	3.00	5.25	8.00
14 × 20 inches . . . . .	2.50	3.75	5.75	8.50
14½ × 22 inches . . . . .	3.00	4.50	6.00	9.00

**CHASES FOR GALLY UNIVERSAL PRESSES.**

	For 10x15 Press.	For 13x19 Press.	For 14x22 Press.
Cast iron . . . . .	\$2.00	\$2.25	\$2.75
Wrought iron . . . . .	5.50	6.50	7.25
*Steel skeleton . . . . .	5.50	6.50	7.25

\* Steel skeleton chases give more lock-up room, but do not add to printing capacity of press.

**CHASES FOR PEERLESS PRESSES.**

	For 8x12 Press.	For 9x13 Press.	For 10x15 Press.	For 11x17 Press.	For 14x20 Press.	For 14½x22 Press.
Cast iron . . . . .	\$1.50	\$1.50	\$2.00	\$2.00	\$2.75	\$3.00

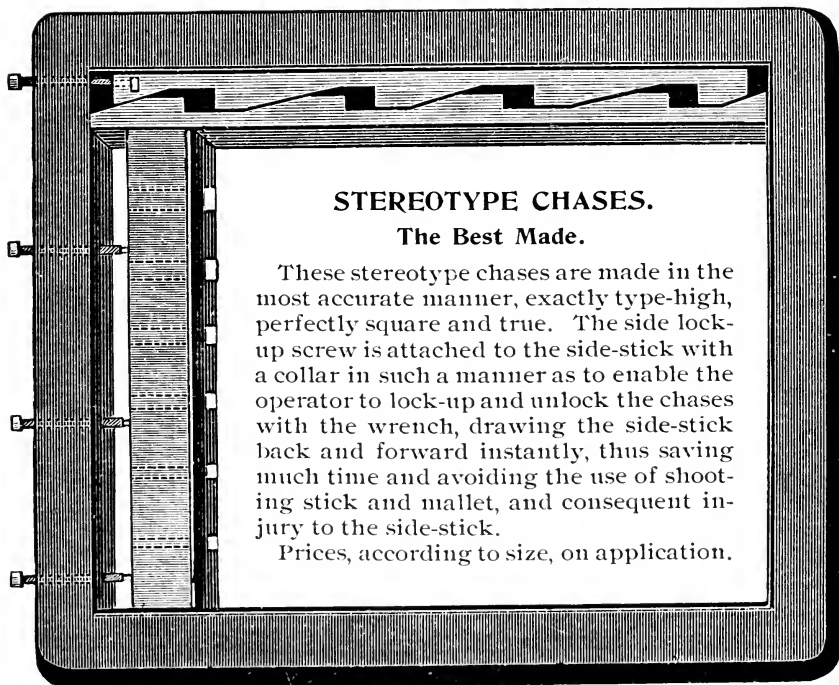

**STEREOTYPE CHASES.**

**The Best Made.**

These stereotype chases are made in the most accurate manner, exactly type-high, perfectly square and true. The side lock-up screw is attached to the side-stick with a collar in such a manner as to enable the operator to lock-up and unlock the chases with the wrench, drawing the side-stick back and forward instantly, thus saving much time and avoiding the use of shooting stick and mallet, and consequent injury to the side-stick.

Prices, according to size, on application.

Lock-up Wrenches for Stereotype Chases . . . . . Price, \$2.50

**MAKE-UP TABLES.**

These tables are used for making-up and carrying forms either to the beating table or matrix rolling machine (or elevator, if the stereotype room is not on the same floor with the composing room), and are very substantially built of hard wood with patent double-roller revolving casters. The iron top is either smoothed off or covered with brass—the latter being preferred by the leading newspaper offices.

Size of Matter.	Price, Iron Top.	Price, Top Covered with Brass.
15 × 20 in. . .	\$40.00	\$50.00
18 × 24 in. . .	50.00	60.00
21 × 28 in. . .	55.00	65.00
24 × 32 in. . .	65.00	75.00

**IRON-TOP BEATING TABLES.**

For Paper Process.

Size of Matter.	Price, Fixed Top.	Price, Elevating Top.
15 × 20 in. . .	\$40.00	\$75.00
18 × 24 in. . .	50.00	95.00
21 × 28 in. . .	55.00	105.00
24 × 32 in. . .	65.00	125.00



IMPOSING TABLES AND MARBLE STONES.



Square-legged Imposing Table.

Square-legged imposing tables are made of soft wood, varnished and bolted together. Round-legged imposing tables are made of hard wood, cherry finish, and are bolted together. Tables over six feet in length have six legs (see illustration on next page). The larger tables have two drawers, one at each end, and the smaller one drawer, which pulls out both sides.

A "coffin" is a hard-wood frame which serves as a bed for the stone, protects its edges, and affords a rest for galleys when used for sliding off matter.

	Imposing Stone only.	Imposing Stone in Coffin.	Round-leg Table and Stone.	Square- leg Table and Stone.
For 6-col. paper, 2 pages, 24×36 in. . .	\$6.00	\$7.75	\$18.75	\$15.00
For 7-col. paper, 2 pages, 26×44 in. . .	8.00	10.00	22.00	18.00
For 8-col. paper, 2 pages, 28×50 in. . .	10.00	12.50	26.50	21.50
For 9-col. paper, 2 pages, 32×60 in. . .	12.50	15.50	30.00	25.50
For 7-col. paper, 4 pages, 26×72 in. . .	13.00	16.75	32.25	27.00
For 7-col. paper, 4 pages, 26×76 in. . .	13.75	17.25	32.25	27.00
For 8-col. paper, 4 pages, 28×80 in. . .	15.50	19.50	37.00	32.00
For 9-col. paper, 4 pages, 30×90 in. . .	18.75	23.50	43.50	38.00
For 6-col. quarto, 4 pages, 36×60 in. .	15.00	18.50	37.00	32.00
For 7-col. quarto, 4 pages, 48×60 in. .	20.00	25.00	45.50	40.00

See cut of Round-legged Table on next page.

**IRON IMPOSING SURFACES** supplied any size to order  
at 2½ cents per square inch.

**MARBLE INK SLABS.**

8×12 inches . . . . .	\$1.25
12×18 inches . . . . .	2.00
18×24 inches . . . . .	3.75

**IMPOSING TABLES WITH LETTER BOARDS.**

No better disposition of the space underneath an imposing table can be made than to use it for letter boards. If the type is dead it is shifted from the stone to the board without loss of time; if the matter is alive, it is handy for imposition.

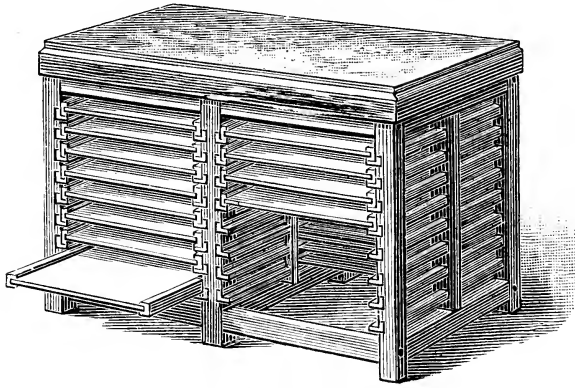

These tables are made in the most substantial manner, of hard wood, varnished, and strongly and firmly bolted together. The boards are made of hard wood, closed at sides and back, and are rabbeted in front to receive galley when sliding off type.

No. 9. With 36 x 60-inch Marble Top; has thirty-two Letter Boards, each 17½ x 26 inches inside.

**Prices with Hard Marble Stones.**

	Number of Boards.	Size of Stone.	Size of Boards.	Without Boards.	Boards each.	Complete with Boards.
No. 2	10	24 x 36	22 x 32			\$40.00
No. 3	10	32 x 48	30 x 44			60.00
No. 9	32	36 x 60	17½ x 26	\$42.50	\$1.00	72.50
No. 10	48	40 x 80	19½ x 22½	55.00	.90	95.50

**ROUND-LEG IMPOSING TABLES.**

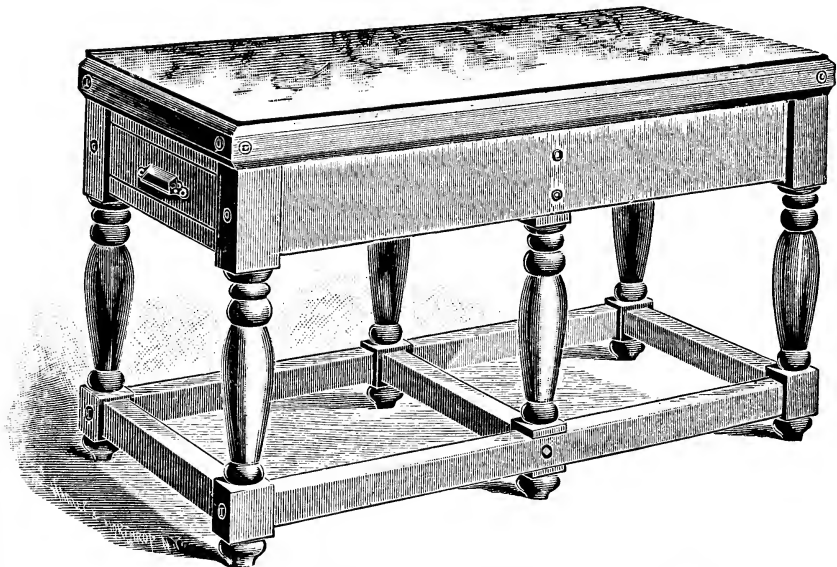

For sizes, prices and description, see preceding page.

AMERICAN TYPE FOUNDERS CO.

WOOD FURNITURE, REGLET AND SIDE STICKS.

Pearl to Pica Reglet . . . . .	Per yard, \$	.02
Great Primer Reglet to 2-line Furniture . . . . .	"	.03
3 to 5-line Furniture . . . . .	"	.04
6 to 9-line Furniture . . . . .	"	.06
10 to 12-line Furniture . . . . .	"	.08
13 to 16-line Furniture . . . . .	"	.10

SIDE STICKS, thin, medium or thick . . . . . " .06

WOODEN QUOINS.

	Boxes of 100.	Burlap Bags of 500.	Burlap Bags of 1000.
Hickory . . . . .	\$ 40	\$1.80	\$3.50
Boxwood . . . . .	60	2.70	5.25
Hickory, in barrels, containing about 7000, per 1000 . . . . .			3.25
Boxwood, in barrels, containing about 7000, per 1000 . . . . .			5.00

LABOR=SAVING REGLET CASES.

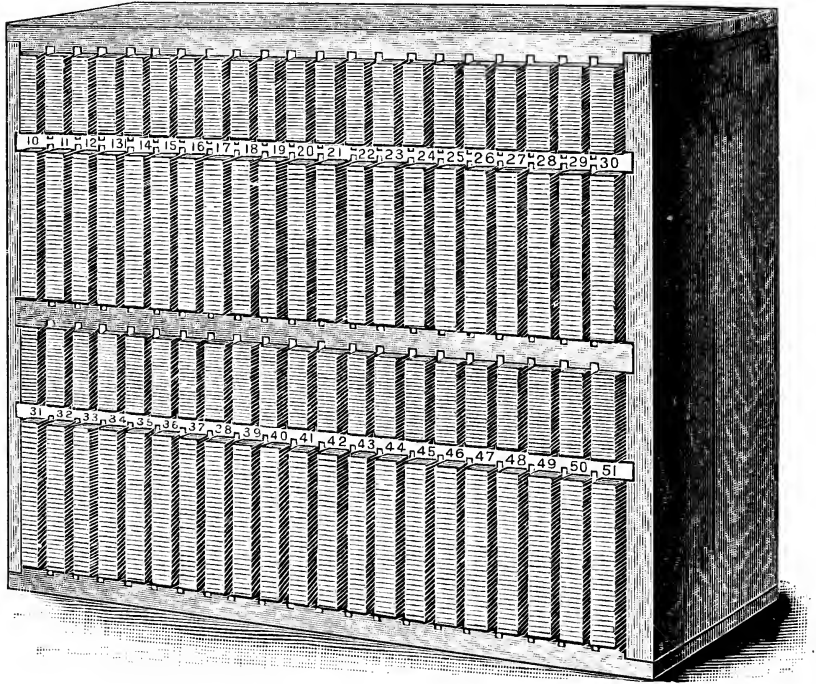

Reglet Case No. 4. 2100 pieces, \$8.00.

Nos. 3, 4, 5, 6 are made same style as above illustration. The reglet lies flat, and varies by ems up to 51 ems, and by 5 ems in longer lengths. Nos. 1 and 2 are square boxes, in which reglet is put in on end, and varies by 10 ems up to 60 ems, with 72 and 120 ems added in the No. 2 case. One-half the pieces in each case are Pica body; the other half, Nonpareil body.

Case.	No. of Pieces.	No. of Yards.	Lengths in Case.	Price.
No. 1 . . . . .	1800	300	10 to 60 ems.	\$ 8.00
No. 2 . . . . .	2400	600	10 to 120 "	14.00
No. 3 . . . . .	4200	550	10 to 51 "	15.00
No. 4 . . . . .	2100	275	10 to 51 "	8.00
No. 5 . . . . .	6300	1500	10 to 150 "	38.00
No. 6 . . . . .	3150	750	10 to 150 "	20.00

LABOR-SAVING FURNITURE.

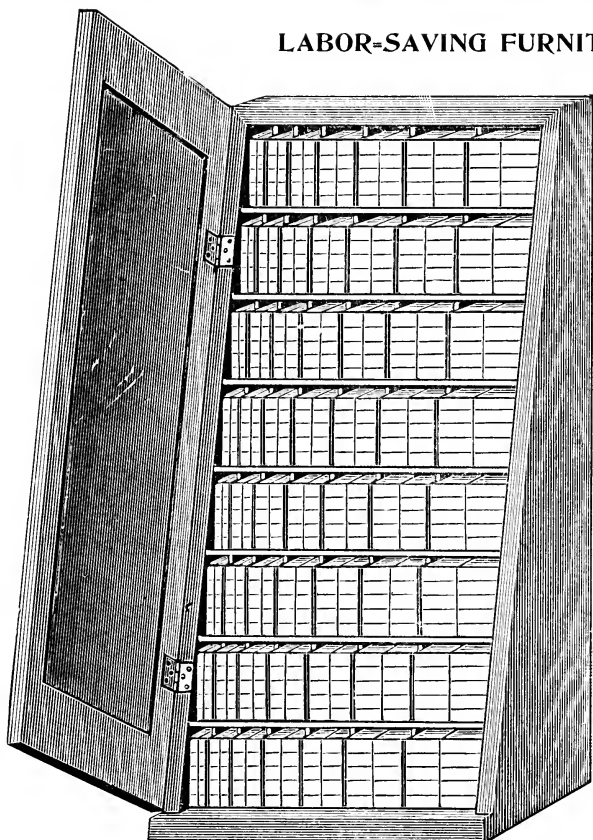

No. 3. Single Case, with Partitions and Door.

This Labor-Saving Furniture is thoroughly oiled, and cut to the point standard. Every piece has the size stamped on the end.

Cases are made *with* or *without* partitions. The usefulness of the font is doubled by having it in a case with partitions.

A Single Case contains 560 pieces, divided into 10 pieces, each 10, 15, 20, 25, 30, 40, 50 and 60 ems long by 2, 3, 4, 5, 6, 8 and 10 ems wide.

A Half Case contains half the number of pieces held in a Single Case.

The Mammoth Case is described below, and is the most complete, well assorted and useful ever put on the market, as a study of its contents will demonstrate.

- No. 1. Half Case contains 280 pieces, with partitions . . . . . \$ 6.00
- No. 2. Half Case contains 280 pieces, without partitions . . . . . 5.00
- No. 3. Single Case contains 560 pieces, with partitions . . . . . 10.00
- No. 4. Single Case contains 560 pieces, without partitions . . . . . 8.00
- No. 5. Double Case contains 1120 pieces, with partitions . . . . . 18.00
- No. 6. Double Case contains 1120 pieces, without partitions . . . . . 15.00
- No. 7. Mammoth Case, designed for large offices, with partitions, no door (see description below) . . . . . 40.00

**MAMMOTH LABOR-SAVING FURNITURE CASE**—Is specially designed for large offices, and contains the following assortment of selected furniture, from 10 to 160 ems long: 270 pieces each 2-line, 3-line and 4-line furniture; 225 pieces each 5-line and 6-line furniture; 135 pieces each 8-line and 10-line furniture—assorted in 10, 15, 20, 25, 30, 40, 50, 60, 70, 80, 90, 100, 120, 140 and 160 ems lengths. There is a larger proportion of the narrower and most-used sizes than of the wide furniture. Made only with partitions.

LABOR-SAVING FURNITURE, WITHOUT CASES.

- Half Font of 280 pieces, in a box . . . . . \$ 2.75
- Single Font of 560 pieces, in a box . . . . . 5.00
- Double Font of 1120 pieces, in a box . . . . . 10.00

LABOR-SAVING LEAD RACKS.

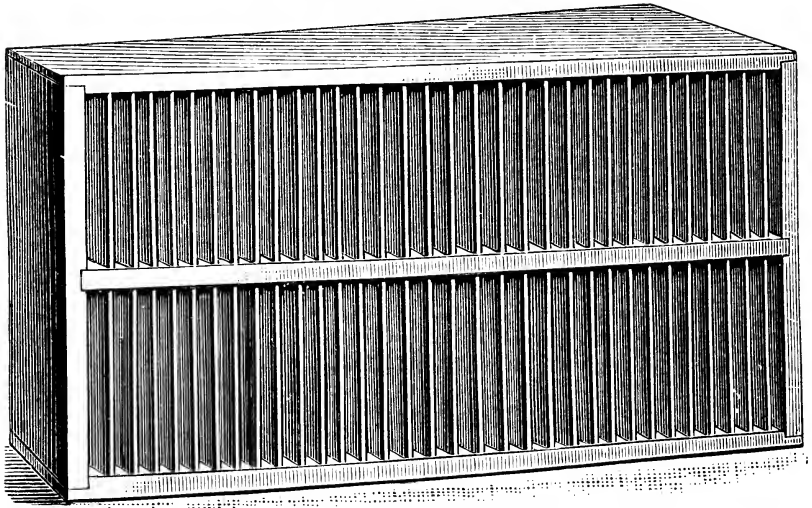

Two-tier Wisconsin Lead Rack (see illustration above) . . . . . \$6.00

Takes leads from 4 to 12½ ems (varying by ems), and from 13 to 60 ems (varying by ems), the lengths being stamped over each compartment. Compartments are eight inches high. Will hold 750 pounds of leads and slugs.

Four-tier Wisconsin Lead Rack . . . . . 9.00

Has two compartments each for all sizes in the two-tier rack, and is similar in design and construction. Will hold 1500 pounds of leads and slugs.

Eureka Lead Rack (see illustration) . . . . . 2.50

Boston Lead Rack, set of four (see illustration) . . . . . 5.40

- No. 1, holds 4 to 15 ems lengths . . . \$ .90
- No. 2, holds 16 to 30 ems lengths . . . 1.20
- No. 3, holds 31 to 45 ems lengths . . . 1.50
- No. 4, holds 47 to 60 ems lengths . . . 1.80

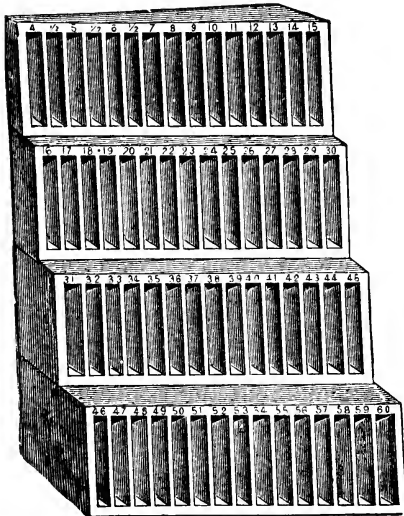

Boston Lead Rack.

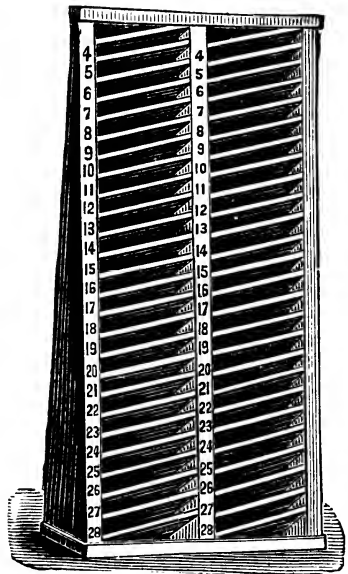

Eureka Lead Rack.



**HANDY LETTER BOARD CABINETS.**

For the storage and safe keeping of job work these cabinets are unri-

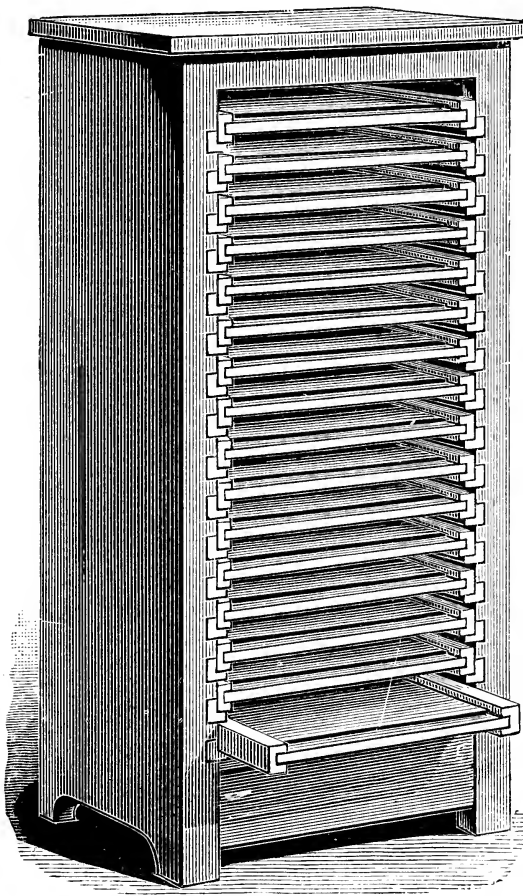

Handy Letter Board Cabinet with Sixteen Boards.

valued. Their cost will be saved in a few months by the prevention of pi. They occupy a floor space of 16 x 19 inches, with letter boards of 12 x 15 inches inside, and are made of hard wood throughout, in a solid and substantial manner. Boards are closed at sides and back, and are rabbeted in front to receive galleys. They are well-named "Handy." For job work within their size—and this the larger variety of such work—these small boards are much superior to the larger boards usually put under imposing tables, as it is a back-breaking job to get a form from these large boards when they are full of type.

It is distinctly an economy to place dead and live forms in such a receptacle as this, rather than to incumber useful space on an imposing stone, the type on which is always liable to damage. The protection they afford from dust is also worthy of consideration.

- With 10 boards . . \$10.50
- With 12 boards . . 12.00
- With 16 boards . . 15.00

Other sizes made to order at proportionate prices.

**HARD-WOOD LETTER BOARDS.**

Made of selected stock, smooth and true, with closed sides and backs, rabbeted in front to allow matter to slide on galleys easily.

No. 1 fits two-third case stands; No. 2, three-quarter stands, and No. 3, full-size stands or racks.

Inches Outside.

- No. 1, 21¾ x 20½ \$1.20
- No. 2, 26¼ x 20½ 1.40
- No. 3, 32¼ x 20½ 1.70

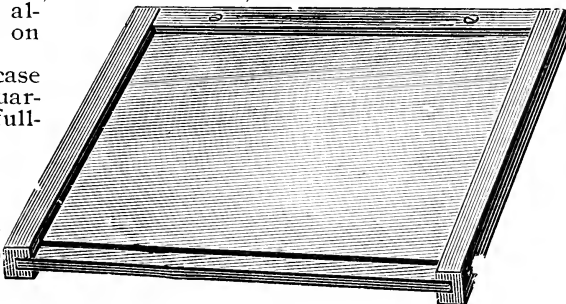

PRICE LIST OF CASES.

For illustrations of cases, see pages 804 and 805.

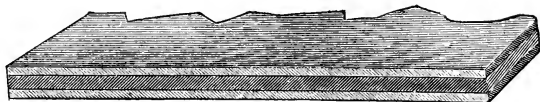

Shows triple, non-warpable, bottom.

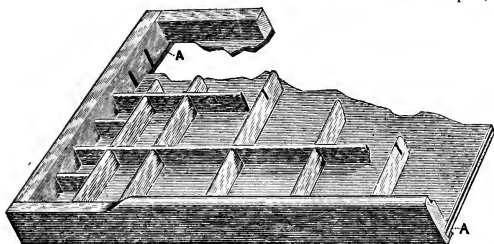

Shows at AA how bottom is set into side and front rails, so that the case slides on the rails instead of the bottom.

the cases slide much easier and with considerable less wear and tear.

Our cases all have patent "New Departure" three-ply bottoms, which prevent splitting, warping and shrinking. These bottoms are set into the side and front rails (see AA), so that the case slides on the side rails. As the grain of the side rails and of the case-runs in stands and cabinets run the same way, the cases slide much easier and with considerable less wear and tear.

FULL SIZE CASES.

Size, 32 1/4 x 16 inches.

News Cases, per pair . . . . .	\$1.60
Cap Case . . . . .	.80
German News Cases, per pair . . . . .	1.60
Italic or Job Case . . . . .	.90
California Job Case (see cut page 804) . . . . .	.90
Yankee Job Case (see cut page 804) . . . . .	1.00
Improved Job Case (see cut page 804) . . . . .	1.20
Triple Case . . . . .	.90
Double Lower Case (see cut page 804) . . . . .	1.20
Rule Case . . . . .	1.15
Lead and Slug Case . . . . .	1.00
Space and Quad Case (see cut page 804) . . . . .	1.00
Border Case . . . . .	1.25
Figure Case . . . . .	1.00
Metal Furniture Case (double depth), takes three layers of Furniture (see cut page 805) . . . . .	2.00
Metal Furniture Case (single depth), takes two layers of Furniture (see cut page 805) . . . . .	1.50
Blank Case . . . . .	.65
Wood Type No. 1 or Script Case, with bars (see page 805) . . . . .	.90

See also Special Wood Type Cases listed on next page.

THREE-QUARTER CASES.

Size, 26 1/4 x 16 inches.

News Cases, per pair . . . . .	\$1.50
Cap Case . . . . .	.75
Italic or Job Case . . . . .	.80
California Job Case (see cut page 804) . . . . .	.80
Yankee Job Case (see cut page 804) . . . . .	.85
Triple Case . . . . .	.80
Blank Case . . . . .	.60

**TWO-THIRD CASES.**

Size,  $21\frac{3}{4} \times 16$  inches.

News Cases, per pair . . . . .	\$1.40
Job Case (thirty-two cap boxes) . . . . .	.75
Yankee Job Case (twenty-eight cap boxes) . . . . .	.75
Improved Job Case ( $21\frac{3}{4} \times 19\frac{3}{4}$ inches). Is deeper than the regular case, and has additional boxes for small caps . . . . .	.90
Lead and Slug Case . . . . .	.75
Brass Leader Case . . . . .	.75
Script Case . . . . .	.75
Border Case . . . . .	.90
Blank Case . . . . .	.45

**ROOKER CASES.**

A popular size for newspaper offices. Not kept in stock. Furnished to order only.

Size,  $28\frac{1}{2} \times 14$  inches.

News Cases, per pair, patent clasp . . . . .	\$1.75
Italic or Job Case, patent clasp . . . . .	1.00

**SPECIAL CASES.**

Wood Type Case No. 1 ( $16 \times 32\frac{1}{4}$ inches) . . . . .	\$ .90
Wood Type Case No. 2 ( $23 \times 32\frac{1}{4}$ inches) . . . . .	1.00
Mammoth Wood Type Case No. 3 ( $23 \times 44$ inches) . . . . .	1.30
Wisconsin Combination "Quarter" Cases, Nos. A, B, C, D, for holding piece fractions, signs, fractions, figures and borders (see cut page 802), each . . . . .	.65

**RULE CASES.**

Regular Rule Case, full size. . . . .	\$1.15
Regular Rule Case, two-third size . . . . .	.90
Compact Rule Case, four of them fit in a full-size blank case, each . . . . .	.90
*Harris Rule Case, No. 1, holds two 8-pound fonts . . . . .	1.25
*Harris Rule Case, No. 2, holds one 16-pound font . . . . .	1.00
*Harris Rule Case, No. 3, } used together, hold one 32-pound font {	1.00
*Harris Rule Case, No. 4, }	1.00
Full-size Blank Case, to hold four Harris Rule Cases . . . . .	.65

\* See cut and description, page 803.

**PATENT CLASP CASES.**

Supplied to order only. Not kept in stock.



These cases are of unusual strength, owing to the use of a brass clasp over the corner of each box and a long pin which is driven through centre of each clasp and clinched, holding the partitions firmly to the bottom of the case.

	Full and $\frac{3}{4}$ Rooker Size. Sizes.
News, per pair . . . . .	\$1.60 \$1.75
German News, per pair . . . . .	1.60 1.75
California Job, each . . . . .	.90 1.00
Italic, each . . . . .	.90 1.00
Triple, each . . . . .	.90 1.00

Section of Patent Clasp Case.

WISCONSIN COMBINATION "QUARTER" CASES.

A	1	2	3	4	5	ä	ë	ï	ö	ü	â	ê	î	ô	û
	6	7	8	9	0	à	è	ì	ò	ù	á	é	í	ó	ú
	.	Em Quad	En Quad	3 Em Space	\$	ç	Ñ	ã	ç	ñ	õ				
C	¼	½	¾	⅓	⅔	⅕	⅖	⅗	⅘	⅙					
	1	2	3	4	5										
	6	7	8	9	0										
D															

Shows four "Quarter" Cases in Full-size Blank Case.

<u>1</u>	<u>2</u>	<u>3</u>	<u>4</u>	<u>5</u>	<u>6</u>	<u>7</u>	<u>8</u>	<u>9</u>	<u>0</u>
1	2	3	4	5	6	7	8	9	0
-	-	SPALES	SPALES	℥	@	℔	%	%	ℓ

For Split Fractions and Commercial Signs.

≡	±	□	□	△	<	√	∛	:	::
∠	∩	'	○		/	3	3	∂	℞
+	-			×					=

For Algebraic and Medical Signs.

Signs, Borders, Accents, Split Fractions, although most expensive, are usually stowed away in odd boxes of cap cases, and are rarely to be found when needed. "Quarter" Cases supply a means of keeping these valuable sorts where they can be found. They can be placed on a cap case, on a stand, or on the stone, convenient to hand of compositor. In setting mathematical work, foreign languages, dictionaries, and special catalogues, these "Quarter" Cases will prove invaluable. We show a few schemes for laying signs, fractions, etc., but various other uses for special purposes will suggest themselves to the "intelligent compositor."

- Quarter Case No. A, for Figures, etc . . . . . \$ .65
- Quarter Case No. B, for Accents, Split Fractions, etc . . . . . .65
- Quarter Case No. C, for Figures and Fractions, etc . . . . . .65
- Quarter Case No. D, for Signs, Borders, etc . . . . . .65
- Per set of four, in regular Full-size Blank Case . . . . . 3.25

The American Type Founders' Company makes the most complete assortment of signs, accented letters, etc., in the world. It is the only complete type-founding concern in the United States.

HARRIS RULE CASES.

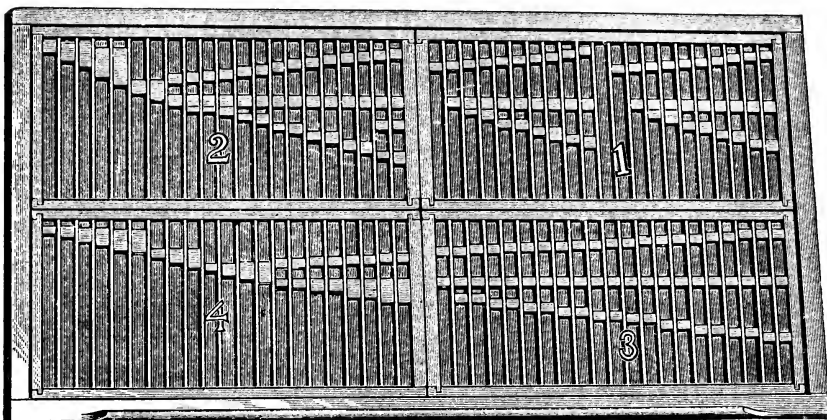

Four Harris Rule Cases in a Full-size Blank Case. Price, \$4.90.

In HARRIS RULE CASES the rule cannot fall flat—must always stay on end. It is prevented, because each box is accurately adjusted for its special size—for instance, a 21-em rule will not go into the 20-em rule box. Generous provision is made for the smaller sizes—the most valuable sizes in a labor-saving font. The cases may be used in sets or separately, as Nos. 1 and 2 are complete in themselves. Four of them fit into a full-size blank case.

The rule referred to below is 2 point, which is the most used.

No. 1 Harris Rule Case holds two complete small fonts of Labor Saving Rule, each weighing 8 pounds, or 16 pounds in all. Each half of this case holds eighteen pieces each length from 1 to 8½ ems (varying by ems), and eighteen pieces each from 9 to 18 ems (varying by ems), and nine pieces each 19, 20, 21, 22, 24, 26 and 28 ems, besides boxes for right and left miters.

No. 2 Harris Rule Case holds one complete font of 16 pounds weight or less. It has compartments for thirty-six pieces each from 1 to 9 ems long (varying by ems), eighteen pieces each from 10 to 24 ems long (varying by ems), and eighteen pieces each of 26, 28, 30, 32, 34, 36 ems long, besides boxes for right and left miters. A large proportion of small lengths allowed for.

Nos. 3 and 4 Harris Rule Cases are designed to be used together to hold a font of rule suitable for a large office, weighing 32 pounds or less. Two and in some cases four boxes are used to hold the most-used sizes. Each case has its proportion of the small sizes, so that if it is desired to carry one case to a compositor's stand for use in rule work, the other is available in its regular place with a good working font. These cases have compartments for seventy-two pieces each from 1 to 9 ems long (varying by ems), thirty-six pieces each from 10 to 24 ems long (varying by ems), and eighteen pieces each from 25 to 36 ems long (varying by ems), and boxes for right and left miters.

Harris Rule Case No. 1, holds two 8-pound fonts . . . . .	\$1.25
Harris Rule Case No. 2, holds one 16-pound font . . . . .	1.00
Harris Rule Case No. 3, } used together, hold one 32-pound font }	1.00
Harris Rule Case No. 4, }	1.00
Full-size Blank Case, to hold four of above . . . . .	.65

ILLUSTRATIONS OF CASES.

It is unnecessary to illustrate the most-used styles of Cases. Those illustrated here have exceptional merit.

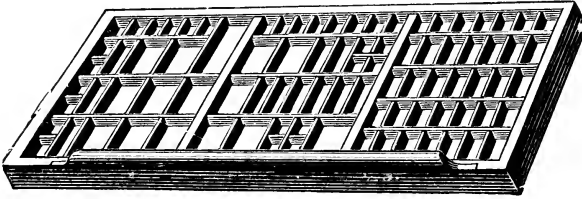

CALIFORNIA JOB CASE.

Has fourteen boxes less on cap side than the regular Italic Job Case, thus giving more space for the cap alphabet. A more satisfactory case for the ordinary job font than the Italic Job Case, especially in three-quarter size.

Full size . . . \$ .90  
Three-quarter .80

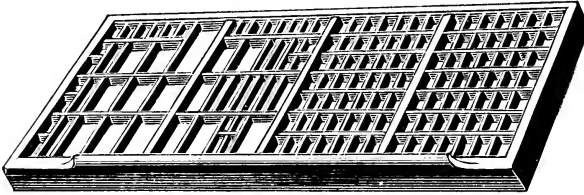

IMPROVED JOB CASE.

Holds caps, small caps, lower case and figures, or a cap and lower case font (with figures) and an extra cap font. Will also hold three cap fonts, all with figures. Made full size only.

Price . . . . \$1.20

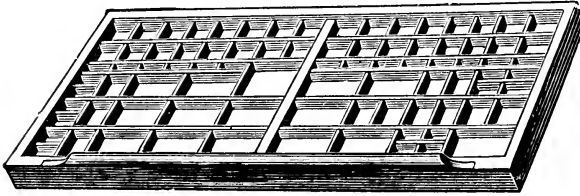

YANKEE JOB CASE.

In two-third size this case is a necessity, but in full and three-quarter sizes it is inferior in utility to other job cases.

Full size . . . \$1.00  
Three-quarter .85  
Two-thirds .75

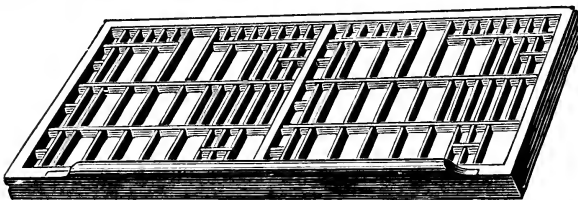

DOUBLE LOWER CASE.

A most useful case. In most job fonts the caps occupy as much space as the lower case, while ordinary job cases give the caps one-half the room allotted the lower case. In this case the space is divided equally between the caps and lower case. Made full size only.

Price . . . . \$1.20

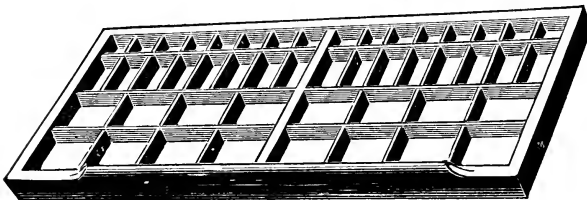

SPACE AND QUAD CASE.

This is an absolutely essential case in offices where economy of time and material is a consideration. Each case holds eight sizes of spaces and quads. Made full-size only.

Price . . . . \$1.00

EVERYTHING FOR THE PRINTER

A handy receptacle for metal furniture. There are compartments for 1, 2, 3, 4, 5, 6, 8, 10, 15, 20, 25 and 50 ems. The double-depth case takes three layers of furniture; the single-depth case takes two layers. The latter can be put in a full-size case stand or rack, and the double-depth case is for use on top of a stand or cabinet, or a special place can be made for it under the stone. Made full size only.

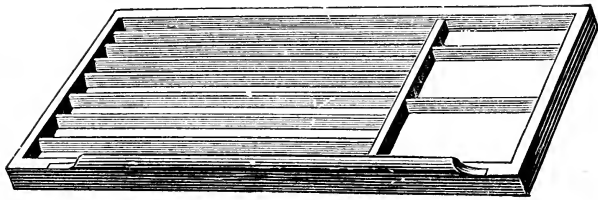

**METAL FURNITURE CASE.**

Double depth . . . . . \$2.00 | Single depth . . . . . \$1.50

Although mostly sold for wood type, these cases are made so accurately as to be suitable for large Script fonts. The movable partitions are adjustable by Picas. Nothing injures expensive Script type so much as tumbling about in a case. The use of Script Cases will save type. Made in full and two-third sizes.

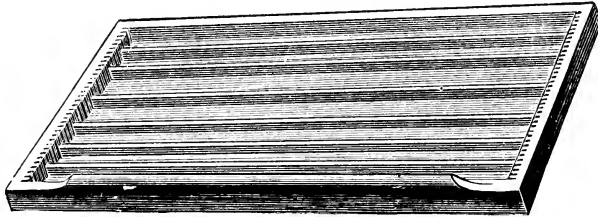

**SCRIPT OR WOOD TYPE CASE.**

Full size . . . . . \$ .90 | Two-third size . . . . . \$ .75

Has compartments for brass rule from 1 to 36 ems Pica, and from 1½ to 9½ ems Pica, with places for miters. Size outside, 7¾ x 15¼ inches. Four fit in a full-size blank case.

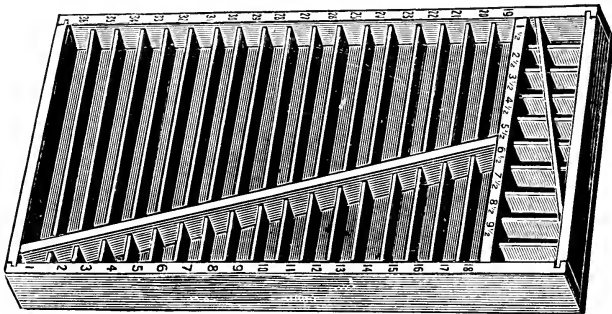

**COMPACT RULE CASE.**

Price . . . . . \$ .90

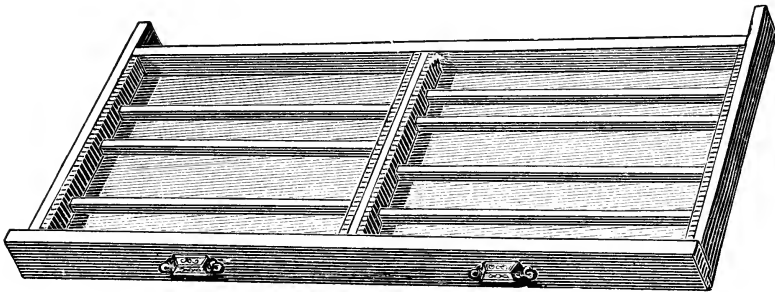

**WOOD TYPE CASE.**

No. 3 (Mammoth) Wood Type Case, 23 x 44 inches, with slotted sides. For special rack to hold this size case, see page 817.

CASE STANDS.

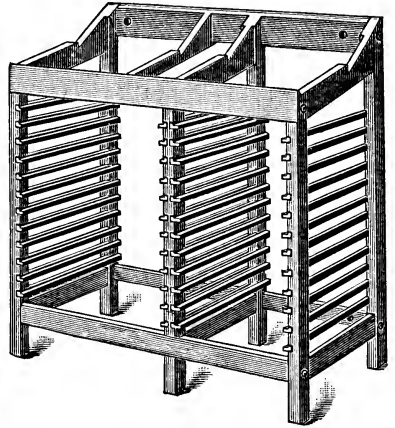
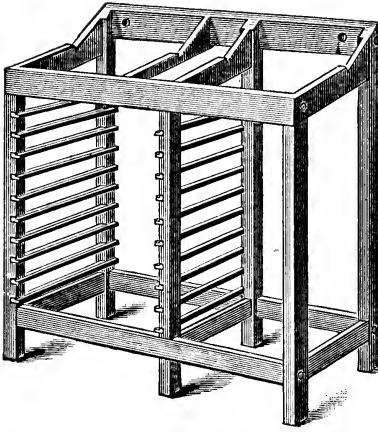

No. 6. Double News Stand, with Eight Racks. No. 11. Double Job Stand, with Racks for Twelve Full and Twelve Two-third Cases.

PRICE LIST OF CASE STANDS.

No. 1.	Single, without racks . . . . .	\$2.75
" 2.	Single, with racks for 12 two-third cases . . . . .	3.00
" 2½	Single, with racks for 12 three-quarter cases . . . . .	3.00
" 4.	Single, with racks for 12 full-size cases . . . . .	3.25
" 6.	Double News, with racks for 8 full-size cases (see illustration) . . . . .	3.75
" 11.	Double Job Stand, with racks for 12 full-size and 12 two-third cases (see illustration) . . . . .	5.50
" 12.	Double Job Stand, with racks for 12 full-size and 12 three-quarter cases . . . . .	5.75
" 15.	Double Stand, with Galley Rest and racks for 24 full-size cases (see illustration) . . . . .	6.00
" 17.	Double City Stand, with racks for 30 full-size cases (see illustration) . . . . .	9.50

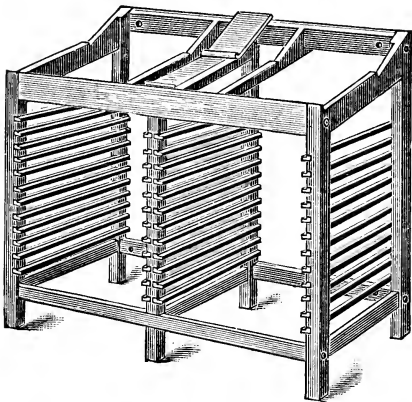

No. 15. Double Stand, with Galley Rest, and Racks for Twenty-four Full-size Cases.

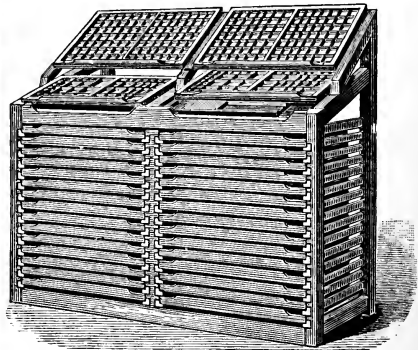

No. 17. Double City Stand. The upper caps project over the lower, bringing the caps nearer the hand. There is a shelf to hold a galley under the lower case, which can be pushed back to permit matter to be emptied on the galley.



NEW YORK SPACE-SAVING CASE STANDS.

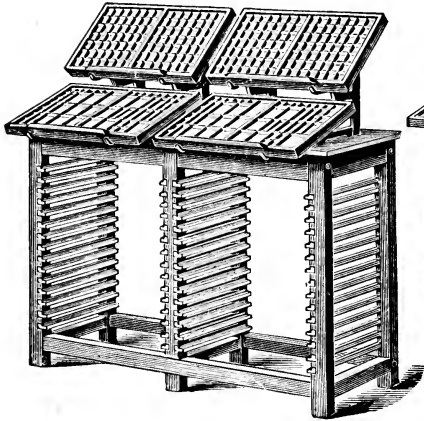

New York Double Stand.

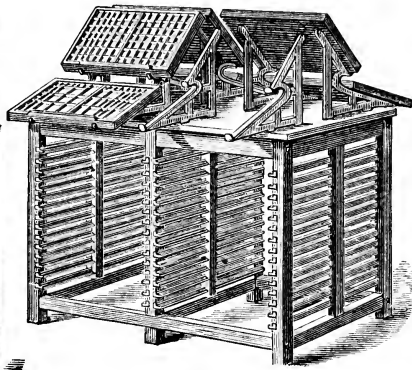

New York Quadruple Stand.  
(See end view below.)

These are *space-saving, rent-reducing stands*. Two New York Double Stands, holding sixty cases in racks and four pairs cases on top, occupy eighteen square feet of floor space, as against thirty square feet occupied by two ordinary double stands, holding at most forty-eight cases in racks and four pairs cases on top—a saving of twelve square feet. Two Double City Stands occupy a floor space of twenty-five square feet as against seventeen feet occupied by one Quadruple New York Stand—a saving of eight square feet. This saving is obtained by making the racks correspond to size of cases exactly, bringing forward the cap cases so that they do not overhang at the back of stand (as they do on ordinary stands), and extending the lower cases several inches into the alley.

Other Points of Superiority.

The lower cases project into the alley several inches, affording the compositor ample leg room, and allowing him to get closer to the type. The angle of the lower case is just right for rapid setting.

The upper case is raised above the lower, and brought forward closer to the compositor's hand, while not obstructing the figure boxes of the lower case.

The cases are held on strong iron brackets, securely screwed to a hard-wood top, which is perfectly smooth, and very useful for storing tied-up matter or for other purposes.

The Window Stand is a rearrangement of the Double Stand, so that it occupies a square area and is very suitable for placing opposite a window.

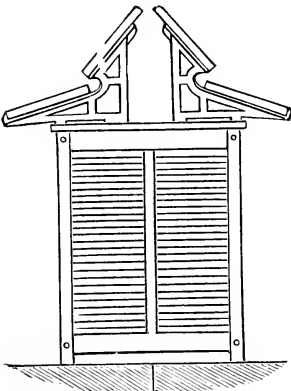

End view of New York Window and Quadruple Stands.

New York Single Stand, with racks for fifteen cases . . . . .	\$6.50
New York Double Stand, with racks for thirty cases . . . . .	10.50
New York Quadruple Stand, with racks for sixty cases . . . . .	18.00
New York Window Stand, with racks for thirty cases . . . . .	10.50

**AUTOCRAT CASE STAND.**

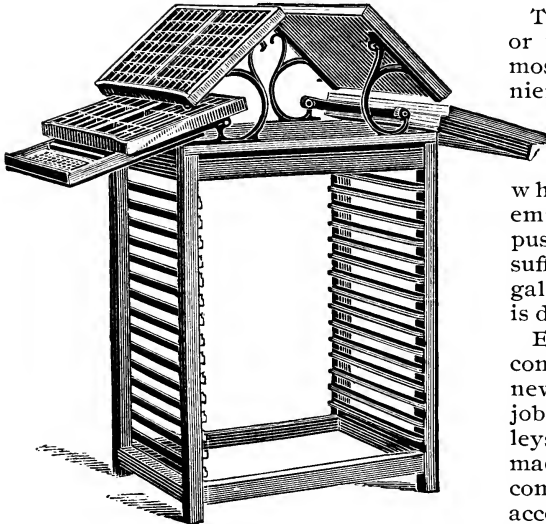

This is a printer's stand or frame in its simplest, most compact and convenient form. The most prominent feature is a Galley Tray, under each lower case, where compositors can empty the sticks by simply pushing the lower case up sufficiently to expose the galley, after which the case is drawn back to its place.

Each Single Stand accommodates two pairs of news cases, fifteen full-size job cases and six news galleys. The Double Stand is made so backs of job cases come together, and will accommodate two pairs of

news cases, thirty full-size job or triple cases and six galleys. A large space on top, back of the brackets, may be used for storing live or dead tied-up matter.

Single Stand for 19 cases . . . . .	\$ 8.50
Single Stand for 19 cases, with paneled ends and back . . . . .	10.00
Double Stand for 34 cases . . . . .	10.00
Double Stand for 34 cases, with paneled ends . . . . .	11.00

**CASE RACKS.**

Made of hard wood, bolted together, and the higher racks are braced at the centre with iron rods to prevent spreading.

Full-size Cases.	Height.	Regular (see cut).	Closed Back and Sides.
Single, to hold 10 cases, 38 in.		\$5.50	\$7.75
Single, to hold 16 cases, 50 in.	7.00		9.50
Single, to hold 20 cases, 60 in.	8.00		11.00
Single, to hold 24 cases, 70 in.	9.00		12.00
Single, to hold 30 cases, 84 in.	10.00		13.00
Double, to hold 40 cases, 60 in.	14.00		17.00
Double, to hold 60 cases, 84 in.	18.00		22.50

Made to hold two-third and three-quarter cases at same prices.

**WOOD TYPE CASE RACK.**

Single, to hold 20 Wood Type Cases, No. 3 . . . . .	\$9.00
---	--------

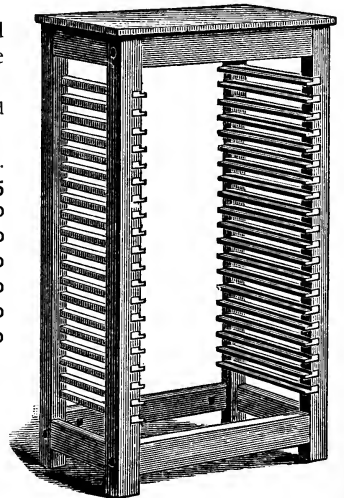

Case Rack to hold Twenty Full-size Cases.

PERFECTION WROUGHT IRON STANDS.

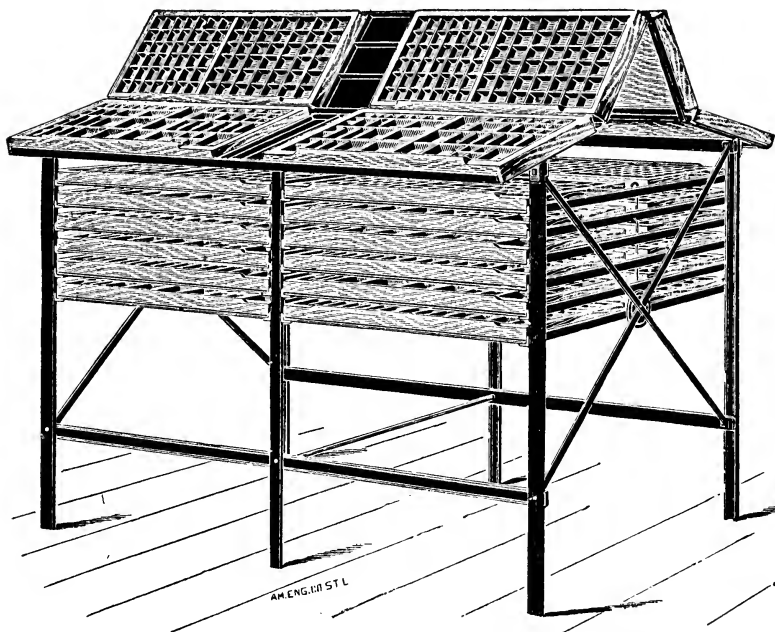

Perfection Quadruple Wrought Iron Case Stand, with Racks for Twenty-four Cases.

The Quadruple Stand has novel features. The cases on top project eight inches from the rack, giving the compositor plenty of knee room. The galleys between top cases are six inches wide, and divided into convenient spaces.

No stands are so durable and "ship-shape"-looking as those made of iron. These stands are exceptionally well made.

Perfection Quadruple Stand, with racks for 24 cases . . . . .	\$30.00
Perfection Quadruple Stand, with racks for 48 cases . . . . .	35.00
Perfection Double News Stand, with racks for 12 cases . . . . .	16.00
Perfection Double Book Stand, with racks for 24 cases . . . . .	20.00
Single News Stand, with racks for 8 cases . . . . .	10.00
Double Job Stand, with racks for 12 full-size and 12 two-third cases . . . . .	20.00
Double Stand (racks back to back), with racks for 12 cases . . . . .	16.00

*Made for full-size, three-quarter or Rooker cases at the same prices.*

REGULAR WROUGHT IRON STANDS.

Made of tubular iron, with strengthened bolted joints. The best made of this class of stand.

No. 2. Regular, Single, with racks for 8 cases . . . . .	\$10.50
No. 5. Regular, Double, with racks for 8 cases . . . . .	13.50
No. 6. Regular, Double, with racks for 8 cases and Galley Rest . . . . .	15.00
No. 8. Regular, Double, with racks for 8 full-size and 8 two-third cases . . . . .	17.00
No. 9. Regular, Double, with racks for 16 cases and Galley Rest . . . . .	18.50

WISCONSIN HARD WOOD CABINETS

With "New Departure" Cases.

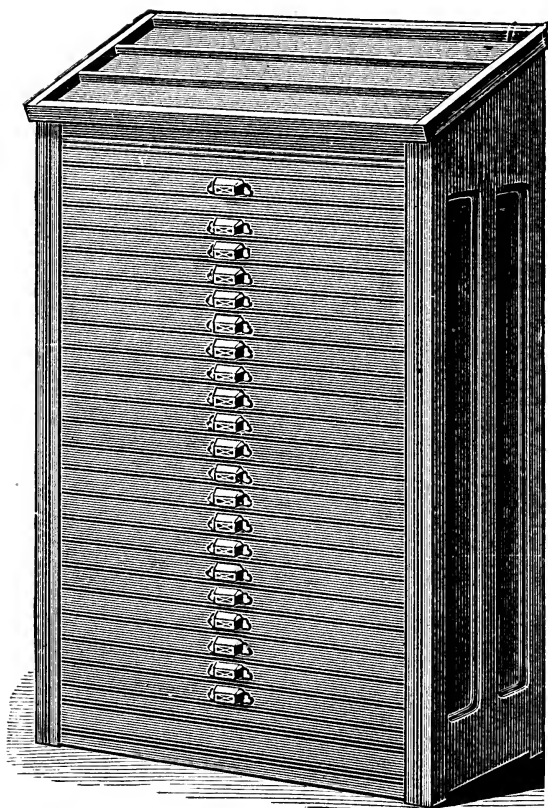

Twenty-Case Galley-Top Wisconsin Cabinet.

*and sixteen cases to order, though not recommended.*

Although made of hard wood, cherry finish, these cabinets are sold at the same prices as ordinary cheap-looking stained cabinets. Three-quarter and full-size cabinets are furnished with California job cases, described on page 804, which are preferable to Italic cases, as they afford more room for the caps. The bottoms are made flush with the floor, to prevent pi from getting underneath. The sides are double paneled and very tastefully moulded. Double case brackets may be put on top of the flat-top cabinets, making a very convenient stand, the regular height from the floor. *Galley-Top Cabinets are kept in stock with twenty cases only, but can be furnished for twelve*

	Flat Top.	Galley Top.
With 12 Two-third Job Cases . . . . .	\$15.00	. . .
With 16 Two-third Job Cases . . . . .	18.00	. . .
With 20 Two-third Job Cases . . . . .	21.00	\$24.00
With 12 Three-quarter California Job Cases . . . . .	18.00	. . .
With 16 Three-quarter California Job Cases . . . . .	22.00	. . .
With 20 Three-quarter California Job Cases . . . . .	26.00	29.00
With 12 Full-size California Job Cases . . . . .	22.00	. . .
With 16 Full-size California Job Cases . . . . .	26.00	. . .
With 20 Full-size California Job Cases . . . . .	30.00	33.00

**DOUBLE CASE BRACKETS, Style A**, which fit on top of flat-top cabinets, to hold a pair of cases (see illustration of bracket, style A, page 821), per pair . . . . . **\$1.50**

AMERICAN STEEL-RUN CABINETS

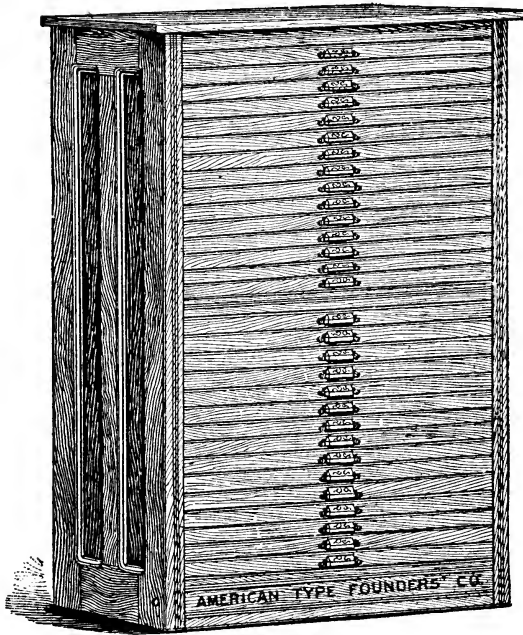

hold 50 per cent. more type in same floor-space occupied by Regular 20-Case Cabinets.

By substituting steel for wood in the runs, the awkward upper projections on the fronts of regular cabinet cases (which in the ordinary are put on to hide the wooden runs) are dispensed with, and ten more cases are got into the same space. Cases are easier to set out of, and all cases are within easy reach of compositors.

The cabinets are made of hard wood, polished, braced in centre to prevent spreading, and California job cases (giving one-third more room for caps by dispensing with two superfluous rows of boxes) are used instead of Italic cases.

The height of the 30-case cabinets is 53 inches; of the 40-case, 68 inches. Cabinets can be supplied any height, but very high cabinets cannot be recommended owing to the loss of time in getting the top cases out of them.

Attention is directed to the common-sense assortment of cases in these cabinets. In thirty cases there will be required some cases for holding cap fonts.

The illustration herewith shows the steel run used in American Cabinets. Screws are countersunk.

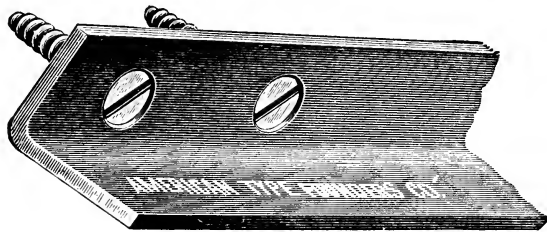

	Flat Top.	Galley Top.
30-case American Steel-Run Cabinet, with 25 two-third job and 5 two-third cap cases . . . . .	\$35.00	\$38.00
30-case American Steel-Run Cabinet, with 25 three-quarter California job and 5 three-quarter cap cases .	40.00	43.00
30-case American Steel-Run Cabinet, with 22 full-size California job, 5 full-size cap, and 3 full-size triple cases . . . . .	45.00	48.00
40-case American Steel-Run Cabinet, with 30 two-third job and 10 two-third cap cases . . . . .	48.00	52.00
40-case American Steel-Run Cabinet, with 30 three-quarter California job and 10 three-quarter cap cases .	53.00	57.00
40-case American Steel-Run Cabinet, with 30 full-size California job, 6 full-size cap, and 4 full-size triple cases . . . . .	60.00	64.00

PORTER'S PATENT EXTENSION FRONT  
STEEL-RUN CABINETS.

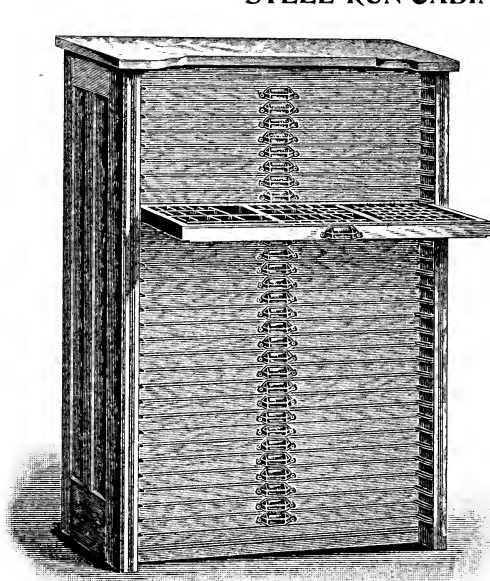

Notice the Extension Sides, the chief merit of this Cabinet.

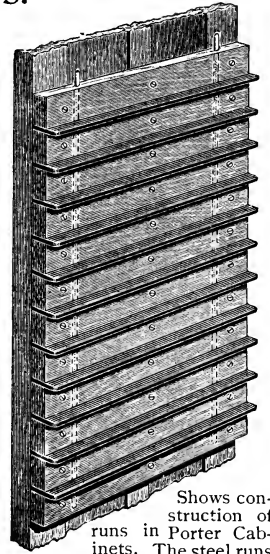

Shows construction of runs in Porter Cabinets. The steel runs are secured between wood, the wood screwed to sides, and two iron rods are passed through as extra strengtheners.

The sides of these cabinets are extended four inches beyond the fronts of the cases. These extensions serve the printer in two ways: (1) A case near the top of a cabinet may be taken from its rack and placed in a more convenient position for setting from, and will be held by the extensions without withdrawing another case. This cannot be done on any other cabinet. (2) The extensions permit cases to be drawn out further from the racks than is possible in other cabinets, making it easier to set out of the rear boxes. In addition, these cabinets have all the best points of other cabinets, such as steel runs, "New Departure" cases, hard wood throughout, and are stronger than any other cabinets, as will be seen by examining the sectional illustration above.

The extension sides make it practicable to use higher cabinets, containing more cases in a tier, than can be advised where ordinary cabinets are used.

- No. 1, with 25 full-size California job cases, one tier, height 45 in. . \$43.00
- No. 2, with 30 full-size California job cases, one tier, height 53 in. . 51.00
- No. 3, with 40 full-size California job cases, one tier, height 68 in. . 68.00
- No. 4, with 50 full-size California job cases, one tier, height 84 in. . 85.00
- No. 8, with 25 full-size blank cases, one tier, height 45 in. . . . . 38.00
- No. 9, with 30 full-size blank cases, one tier, height 53 in. . . . . 45.00
- No. 10, with 40 full-size blank cases, one tier, height 68 in. . . . . 60.00
- No. 11, with 50 full-size blank cases, one tier, height 84 in. . . . . 75.00

Porter Cabinets of greater height can be supplied if desired. As all the above cabinets have flat tops we do not list any double cabinets. A double 25-case (50 cases in all) will cost \$85; a double 30-case, \$100. Single tier, flat-top cabinets are always preferable to double, because it is easier to find positions for them. They are moved easier, and there is no saving in space by using double flat-top cabinets.

**COMBINATION CABINET No. 1.**

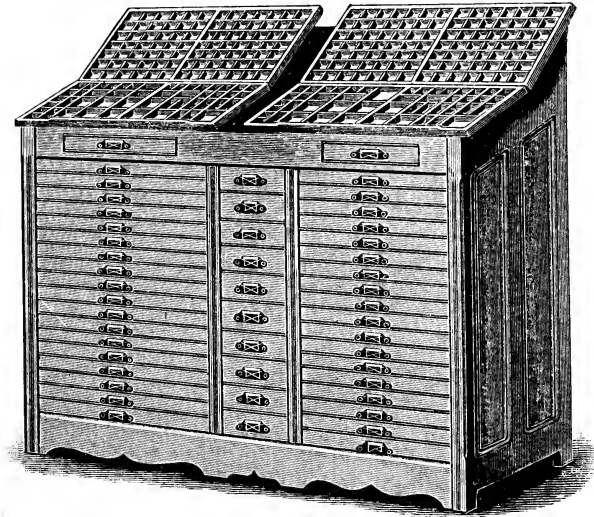

Made of hard wood, cherry finish. Contains 18 full-size California job, 18 two-third job, 2 pairs full-size news cases on top, 2 copy drawers, and 10 sort drawers with partitions. . . . . \$75.00

**EAGLE CABINET.**

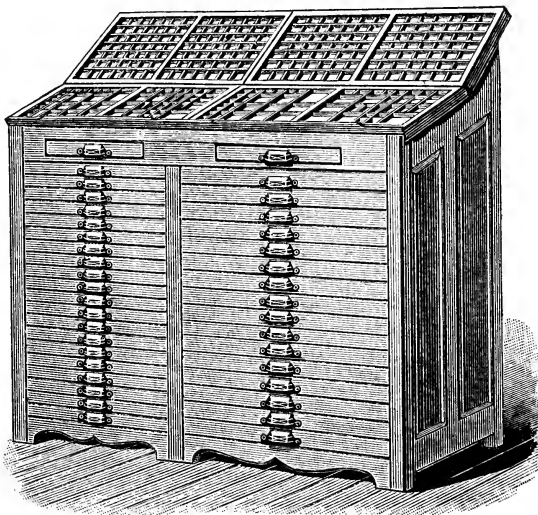

Made of hard wood, cherry finish. Contains 40 cases in all, including 12 full-size California job, 2 each full-size triple and cap cases, 20 three-quarter California job cases, 2 pairs full-size news cases on top, and 2 copy drawers . . . . . \$70.00

**“AMERICAN-POLHEMUS” CABINETS.**

All Hard Wood, Cherry Finish.

The object of the American-Polhemus Cabinet is to save time and space. Time is lost on the ordinary cabinets by stationing the compositor in front of twenty cases, all frequently in use by other men, who, when setting or distributing from them, keep the man at the cabinet idle. On the American-Polhemus cabinets the job cases are unobstructed, and the compositor stands at the back, where he cannot be interrupted. If he is setting solid matter he can empty his sticks, without walking a step, on a galley kept under his lower case, as the cases are held by the Patent Tilting Bracket and Galley Rest. Illustrated on page 815.

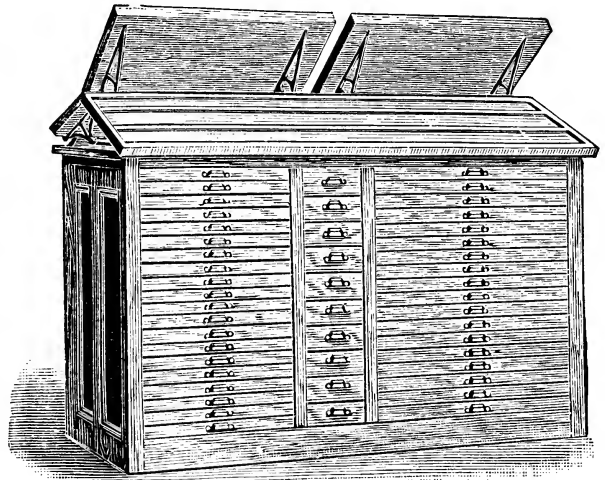

Front view of American-Polhemus Double Cabinet, showing Sort Drawers, Galley Top and Job Cases.

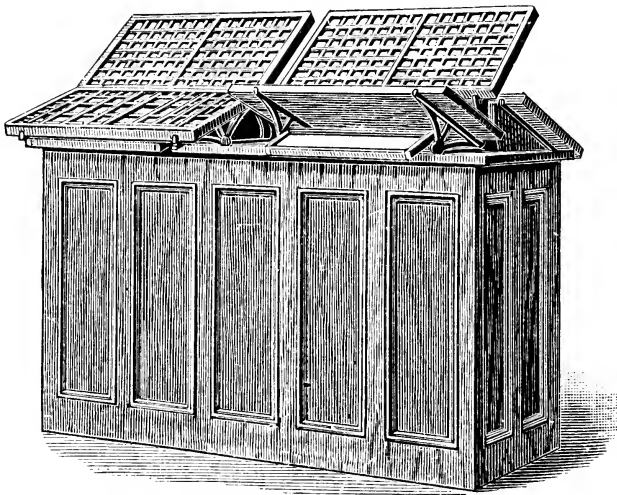

Back of Double Cabinet, showing arrangement of News Cases on the Patent Tilting Brackets.

Every inch of space on the American-Polhemus cabinets is utilized to advantage. The galley top or bank is a most useful addition. The space between the cases is used as a sort cabinet. The top is flat, and tied-up matter may be kept on it, as the iron case brackets admit of easy access to the space under the cases and galley top. The brackets which hold the cases project into the alley eight inches, giving the compositor plenty of knee-room, while saving floor space.

- Single American-Polhemus Cabinet—Complete with 18 full-size California job cases, 1 pair of news cases, galley top, and 1 pair of patent tilting brackets. **\$35.00**
- Double American-Polhemus Cabinet—Complete with 18 full-size and 20 three-quarter California job cases, 2 pairs of news cases, galley top, 10 sort drawers, and 2 pairs of patent tilting brackets. **75.00**
- Triple American-Polhemus Cabinet—Complete with 18 full-size and 40 three-quarter California job cases, 3 pairs news cases, galley top, 10 sort drawers, galley rack, and 3 pairs of patent tilting brackets. **110.00**



**STEEL-RUN AMERICAN-POLHEMUS CABINETS.**

**All Hard Wood, Cherry Finish.**

These cabinets are similar to the American-Polhemus Cabinets, illustrated on opposite page, except that the use of steel runs instead of wood runs increases their case-holding capacity without changing floor space or height.

- No. 5½. Double American-Polhemus Cabinet—Contains 18 full-size California job, 3 full-size triple, 4 full-size cap, 20 three-quarter California job, 5 three-quarter cap, and 2 pairs of full-size news cases on top, 10 sort drawers, a galley top, and 2 pairs of patent tilting brackets . . . . . \$95.00
- No. 6½. Double American-Polhemus Cabinet—Contains 43 full-size California job, 4 full-size cap, 3 full-size triple, and 2 pairs of full-size news cases on top, a galley top, and 2 pairs of patent tilting brackets (*no sort drawers*) . . . . . 95.00
- No. 7½. Single American-Polhemus Cabinet—Contains 19 full-size California job, 3 each full-size triple and cap cases, 1 pair of full-sized news cases on top, a galley top, and 1 pair of patent tilting brackets . . . . . 47.00

**WISCONSIN WINDOW CABINET.**

Specially designed for placing in front of a window, as it does not obstruct the light, of which the cases on top get the full benefit. Two men may work undisturbed at the sides, while the job cases in front are convenient for other men. The top is flat, and useful for holding tied-up type.

These cabinets have the patent tilting bracket and galley rest, which enables a compositor to empty his stick without leaving the cabinet by simply tilting his lower case, as shown in the cut, thus exposing the galley.

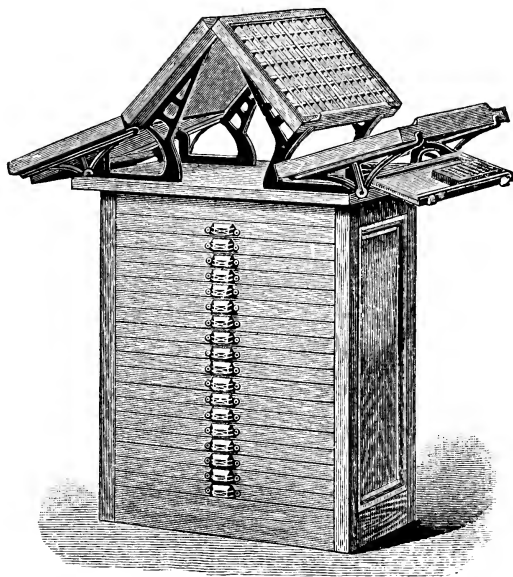

**PATENT TILTING CASE BRACKET.**

Used on Wisconsin Window and American-Polhemus Cabinets.

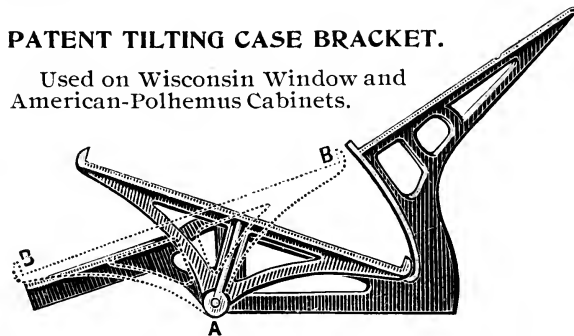

B B (outline) shows bracket holding case in position for setting. Shaded cut shows bracket tilted up, allowing compositor to empty his stick without leaving the cabinet by simply tilting his lower case, as shown in cut of Wisconsin Window Cabinet printed above. These brackets are supplied with all American-Polhemus Cabinets.

Wisconsin Window Cabinet, with two pairs of Patent Tilting Brackets and eighteen full-sized California job cases, two pairs of news cases on top, hard wood, cherry finish . . . . . \$36.00

ROWEN BORDER AND SCRIPT TYPE CABINETS.



Rowen Border Cabinet with Twenty Cases.

These cabinets supply the long-felt need of a proper receptacle for borders, keeping them in compact shape and preserving the face.

The cases in these cabinets are 10×12 inches inside, and are tilted sufficiently to keep the type on its feet. The borders or type are held between movable division strips, which are 18 points wide, while the slots into which these strips fit are set 6 points apart, so that they can be adjusted to hold 6, 12, 18, 24, 30, 36, 42, 48, 54, 60, or 72-point bodies, while such irregular and seldom-used bodies as 8 and 9 point may be carried in the 12-point drawers, or special strips may be procured for them.

For script type a quantity of metal pinch springs is furnished with each cabinet, for inserting between the different letters in a font, so that if all the letters "d" are removed, the pinch spring holds the letters "e" on their feet. The advantages of keeping delicate scripts in cases where the faces of the letters are not subject to friction and scratching will be apparent to all.

No. 1, 4 drawers, one tier, height 12 inches . . . . .	\$ 8.00
No. 2, 6 drawers, one tier, height 16 inches . . . . .	10.50
No. 3, 10 drawers, one tier, height 25 inches . . . . .	16.00
No. 4, 16 drawers, two tiers, height 21 inches . . . . .	25.00
No. 5, 20 drawers, two tiers, height 25 inches . . . . .	30.00
No. 6, 30 drawers, two tiers, height 35 inches . . . . .	45.00
No. 7, 40 drawers, two tiers, height 44 inches . . . . .	60.00

Each case will hold 30 feet of 6-point, or 24 feet of 12-point, or 20 feet of 18-point, or 17 feet of 24-point, or 15 feet of 30-point, or 13 feet of 36-point borders.

WOOD TYPE CABINETS.

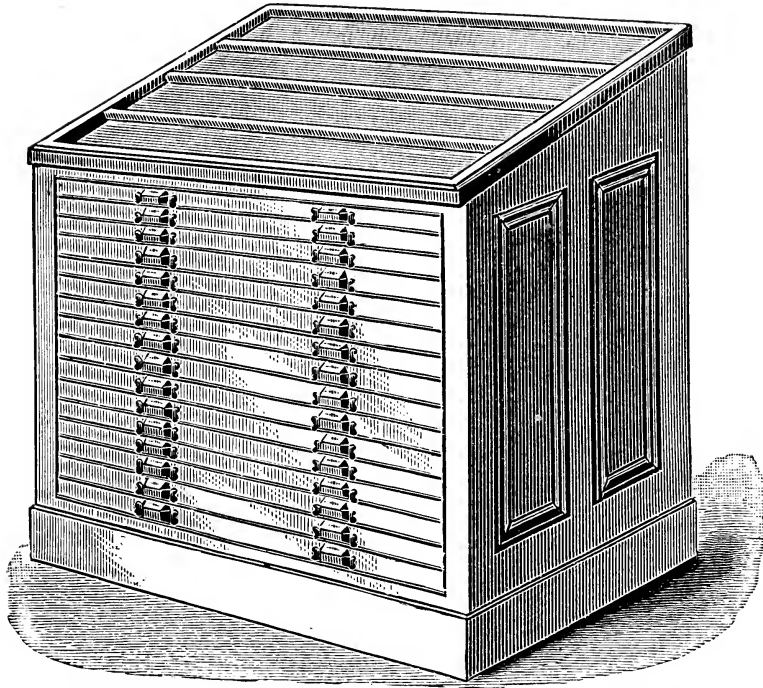

No. 5 Wood Type Cabinet, with Galley Top. Occupies nine square feet floor space, and affords one hundred and twelve square feet for storage of type.

Very substantially constructed of hard wood, cherry finish. The cases are slotted on the sides, and have movable strips which may be adjusted to Picas. The cases in the Mammoth Cabinet (23×44 inches) have a centre bar, and cases in the Regular Cabinet (23×32 inches) have no centre bar.

These cabinets afford the most economical method of keeping wood type. The top of cabinet is available for use in laying out lines. They save the time lost in climbing to shelves, and the wood type is kept clean and is less liable to warp.

		Flat Top.	Galley Top.
No. 1.	12 cases, 23×32 inches . . . . .	\$20.00	\$23.00
No. 2.	16 cases, 23×32 inches . . . . .	25.00	28.00
No. 3.	20 cases, 23×32 inches . . . . .	30.00	33.00
No. 4.	12 cases, 23×44 inches . . . . .	25.00	28.00
No. 5.	16 cases, 23×44 inches . . . . .	33.00	36.00
No. 6.	20 cases, 23×44 inches . . . . .	40.00	45.00

WOOD TYPE CASE RACK,

To hold twenty No. 3 Wood Type Cases (made to order) . . . . . \$9.00

For prices of Wood Type Cases, see page 801. No. 3 Wood Type Cases are 23 x 44 inches over all, and the price is \$1.30 each.

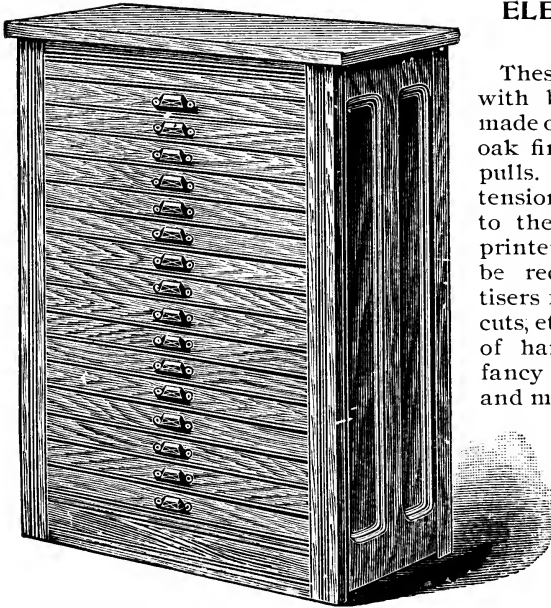

Flat-Top Sixteen-Case Electro Cabinet.

**ELECTRO AND CUT CABINETS.**

These cabinets are filled with blank cases, and are made of polished ash, antique oak finish, with bronze case-pulls. The cases have extension backs. In addition to the ordinary use of the printer, these cabinets can be recommended to advertisers for keeping their wood cuts, etc., for keeping samples of hardware, confectionery, fancy stationery, for seeds, and many other purposes.

All sizes can be supplied with galley tops at an advance of \$3.00 on flat-top prices, but galley tops are not recommended except on 20-case cabinets.

	Size of Case, Inches.	Height or Cabinet.	Flat Top.	Galley Top.
12 Two-third Blank Cases . . . . .	16 × 21¾	34 inches	\$12.00	.. . .
16 Two-third Blank Cases . . . . .	16 × 21¾	42 inches	14.00	.. . .
20 Two-third Blank Cases . . . . .	16 × 21¾	50 inches	16.00	\$19.00
12 Three-quarter Blank Cases . . . . .	16 × 26¼	34 inches	15.00	.. . .
16 Three-quarter Blank Cases . . . . .	16 × 26¼	42 inches	18.00	.. . .
20 Three-quarter Blank Cases . . . . .	16 × 26¼	50 inches	21.00	24.00
12 Full-size Blank Cases . . . . .	16 × 32¼	34 inches	19.00	.. . .
16 Full-size Blank Cases . . . . .	16 × 32¼	42 inches	22.00	.. . .
20 Full-size Blank Cases . . . . .	16 × 32¼	50 inches	25.00	28.00

**PAPER AND CARD STOCK CABINETS.**

Made very strongly of hard wood, cherry finish. High-priced papers and cardboard should be kept in a dust-tight receptacle, to prevent wastage and economize space.

No. 1, 12 drawers, each drawer holding 22½ × 28-inch cardboard, or smaller.

Price . . . . . \$37.00

No. 2, 12 drawers, each drawer taking full sheet of 28 × 42 inches.

Price . . . . . \$48.00

The cabinets are 48 inches high. The drawers are 2½ and 5 inches deep, and have movable partitions.



No. 1 Paper Stock Cabinet. Occupies 26x34 inches floor space.



**SPECIMEN CABINETS.**

Made in ash, with antique oak finish. These cabinets are handsomely made, and will be an ornament to any office.

The drawers have movable partitions, and are made in two depths— $2\frac{1}{2}$  inches and 5 inches. The No. 1 Cabinet is the proper height for placing a letter-copying press on.

The methodical classification and preservation of specimens in a cabinet enables customers to decide on what they want quickly, and in many cases suggests other requirements. Let the public see what you have to sell, and they will become buyers.

No. 1 Specimen Cabinet, 26 inches wide, 42 inches high, and 19 inches deep.

- No. 1. 8 drawers, 26 ins. wide by 19 ins. deep by 42 ins. high . . . \$14.00  
 No. 2. 12 drawers, 26 ins. wide by 19 ins. deep by 50 ins. high . . . 20.00

**BOOKBINDERS' CABINETS.**

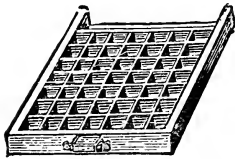

Cases used in Bookbinders' Cabinet.

Made of hard wood, cherry finish, with bronzed pulls on each case. The cases are made in exactly the same style as printers' cases. These cabinets occupy a space of  $20 \times 20$  inches,

and may be put on or under a bench. "A place for everything and everything in its place" is a rule bookbinders should live up to, and these cabinets enable them to do so.

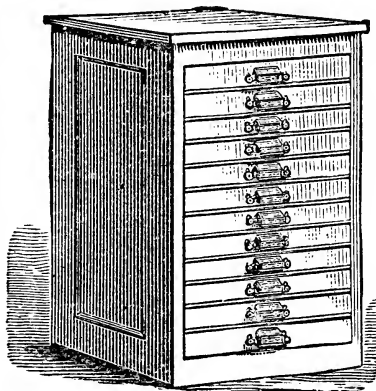

- Cabinets with 6 cases . . . . . \$ 8.00  
 Cabinets with 10 cases . . . . . 12.00  
 Cabinets with 15 cases . . . . . 16.50

**BOOKBINDERS' CASE** (Half Cap Case),  $16 \times 16\frac{1}{4}$  inches, without bronze pull, each. . . . . .60

**HANDY SORT CABINETS.**



Handy Sort Cabinet, with thirty drawers.

Cabinet with 10 Handy Sort Drawers . . . . .	\$12.00
Cabinet with 20 Handy Sort Drawers . . . . .	23.00
Cabinet with 30 Handy Sort Drawers . . . . .	35.00
Cabinet with 40 Handy Sort Drawers . . . . .	47.00
Cabinet with 50 Handy Sort Drawers . . . . .	59.00

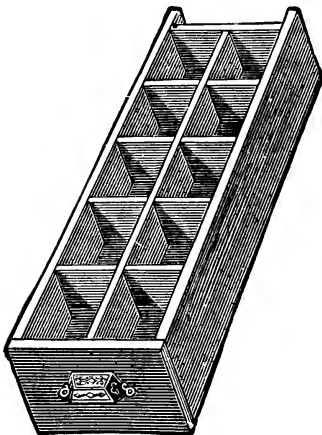

These cabinets are fitted with serviceable sort drawers which should supplant the various cigar-box-tin-can arrangements which disgrace so many offices. The drawers are 8 x 20 inches over all, and two inches deep. The cabinets are very strong, made of hard wood, and remarkably low-priced. The drawers, which are also for sale separately, have movable partitions, and may be adjusted to the special requirements of any printing office. All drawers have strong bronze drawer-pulls, whether sold in cabinets or separately.

**HANDY SORT DRAWERS.**

Each . . . . . \$ .90

Sort Cabinets made to order to fit any space, or to any dimensions, at proportionate prices.

BRASS LABEL HOLDER.

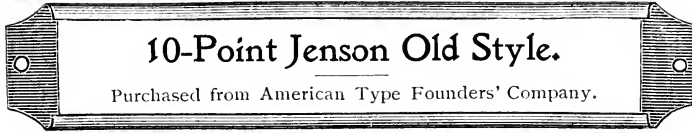

The utility of these Label Holders is apparent at a glance, especially when extra men are put on, as it enables them to locate the type quickly.

Size,  $1 \times 5\frac{1}{2}$  inches, per hundred, with cards and tacks complete . . \$2.75

Size,  $1 \times 5\frac{1}{2}$  inches, per dozen (least quantity sold), complete . . . .50

Other sizes furnished to order.

BRACKETS.

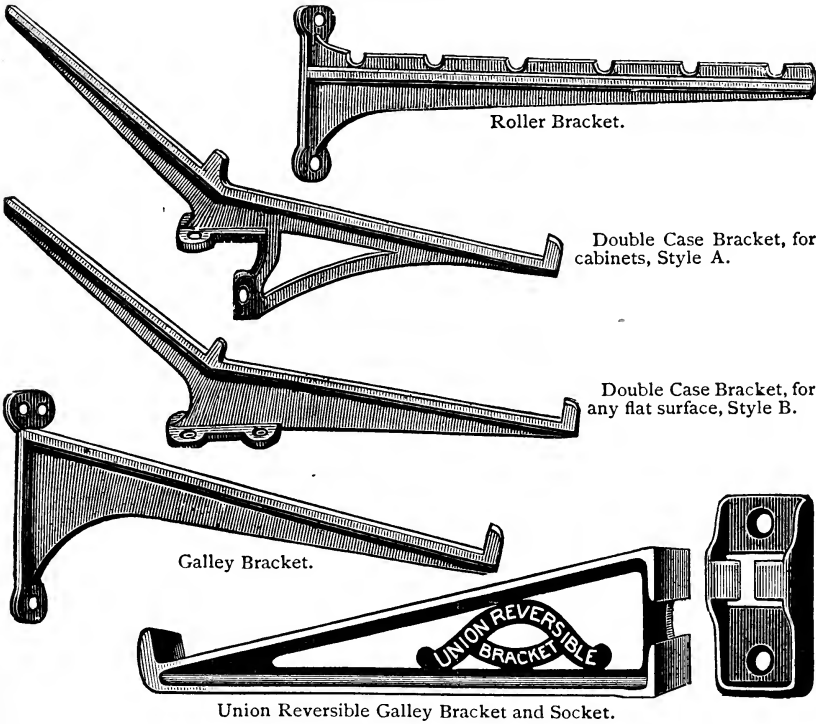

Roller Bracket.

Double Case Bracket, for cabinets, Style A.

Double Case Bracket, for any flat surface, Style B.

Galley Bracket.

Union Reversible Galley Bracket and Socket.

Double Case Brackets, style A, fit on end of Flat Top Cabinet, per pair . . . . .	\$1.50
Double Case Brackets, style B, fit on any flat surface, per pair . . . . .	1.25
Single Case Brackets, per pair . . . . .	.75
Galley Brackets, per pair . . . . .	.40
Roller Brackets, to hold six platen press rollers, per pair . . . . .	.50
Union Reversible Galley Brackets, with Sockets, per pair . . . . .	.60
Union Reversible Galley Brackets, with Sockets, per dozen pairs	6.00

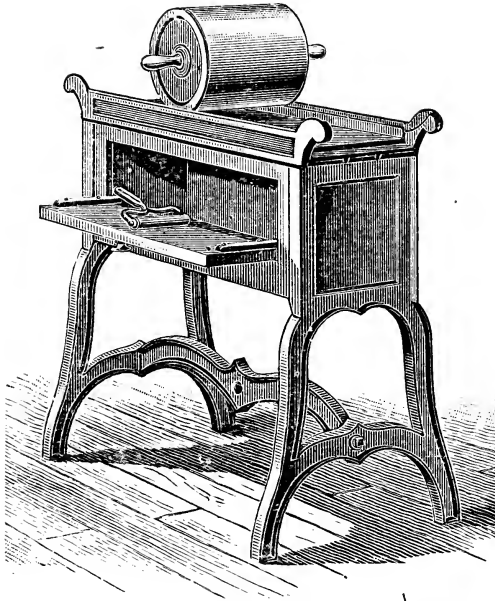

**GALLEY  
PROOF PRESS.**

**With Iron Stand:**

- No. 1, 10×31 in. . . . \$30.00
- No. 2, 16×31 in. . . . 42.00

**Without Stand:**

- No. 1A, 10×31 in. . . \$22.50
- No. 2A, 16×31 in. . . 30.00

Each proof press is furnished with blanket, brayer frame and stock.

**WEB SUCCESS  
SELF-INKING  
PROOF PRESS.**

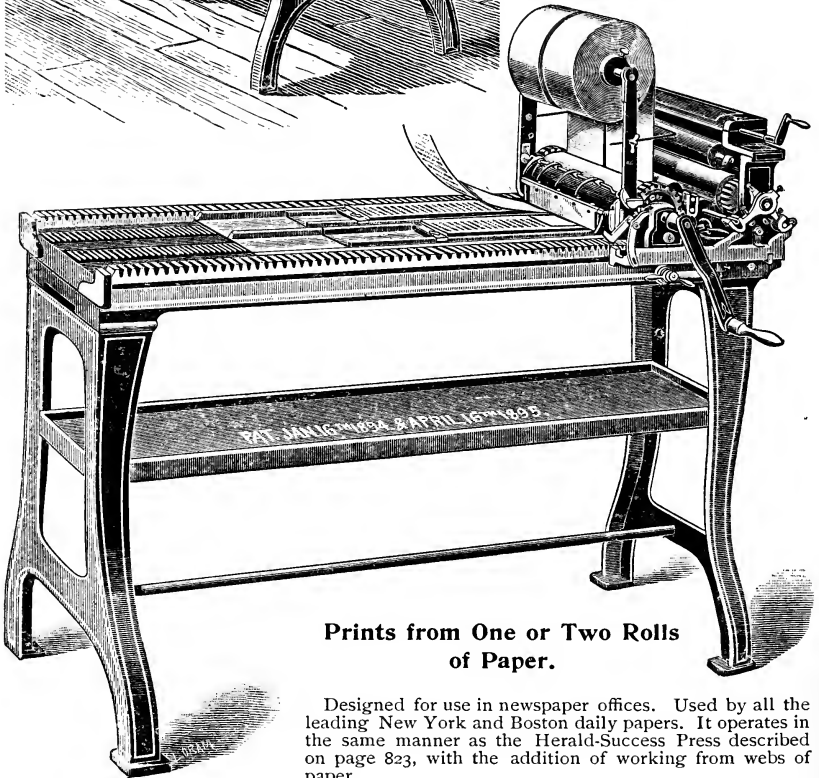

**Prints from One or Two Rolls  
of Paper.**

Designed for use in newspaper offices. Used by all the leading New York and Boston daily papers. It operates in the same manner as the Herald-Success Press described on page 823, with the addition of working from webs of paper.

- With 10-inch bed, for one web of paper; for proving single, double or triple-column galleys . . . . . \$300.00
- With 12-inch bed, designed for taking two webs and taking two single-column galley proofs at once, or double, triple or quadruple column proofs by using wider single webs . . . . 400.00



**ECONOMIC  
PROOF PRESS.**

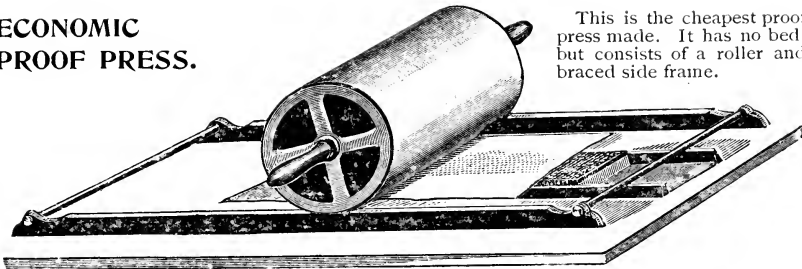

This is the cheapest proof press made. It has no bed, but consists of a roller and braced side frame.

A mould is provided for casting weights which can be placed inside the cylinder to increase pressure according to character of the work.  
10×34 inches inside, complete with blanket and weight mould . \$13.50

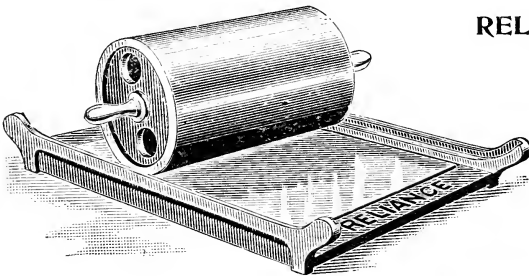

**RELIANCE JOB GALLEY  
PROOF PRESS.**

Designed for taking proofs of job work.

No. A, without table, takes 14×20 job galley . . . . . \$22.50

No. B, without table, takes 15×22 job galley . . . . . \$25.00

**HERALD-SUCCESS  
SELF-INKING  
PROOF PRESS.**

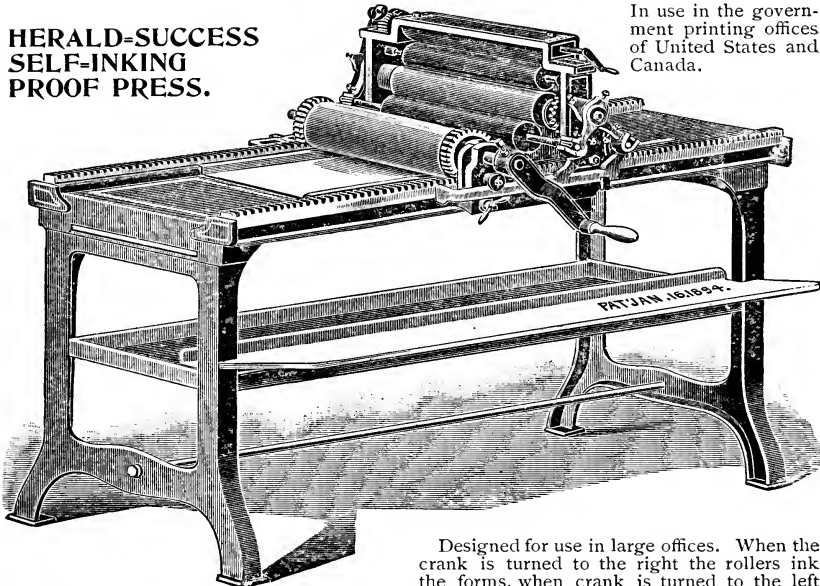

In use in the government printing offices of United States and Canada.

automatic. Impression cylinder is covered with seamless vulcanized rubber, taking clean and sharp impressions.

With 18-inch bed, capable of proving four single-column galleys at one impression, or large magazine pages . . . . . \$300.00  
With 24-inch bed, adapted for full-page newspaper proofs . . . . . 400.00

**PRINTERS' SAW TABLE, With Shoot-Board Attached.**

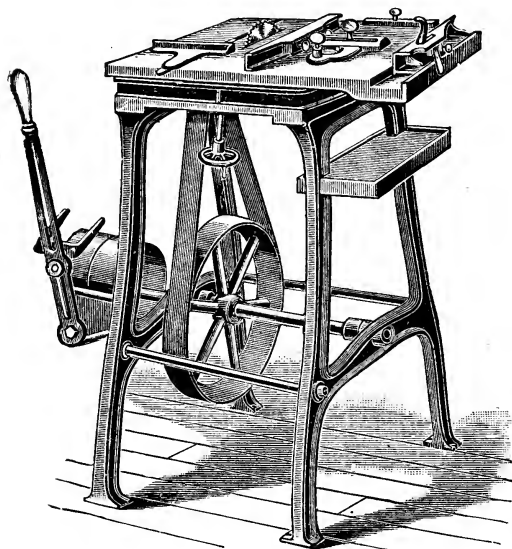

A very necessary machine in large printing offices. It will saw wood, metal or brass, and will trim wood and metal accurately from the merest shave upward. It affords the quickest and most accurate method of cutting slugs, furniture, thick brass rule and plates, and as it is fitted in the most complete manner with gauges, all cutting and trimming is done with perfect squareness and trueness. An attachment for sawing linotype slugs is furnished for \$15.00 extra.

This is a thoroughly well-built machine, equal to similar machines used by electrotypers, made of iron and steel, with accurate ad-

justable gauges. The saw is raised or lowered by means of a clamp-screw set under the table. The countershaft is attached to the saw and should not run less than four hundred revolutions per minute. The driving pulley is 7 inches in diameter, for 2½-inch belt. Size of table is 18×24 inches, height 40 inches, and floor space occupied 24×32 inches.

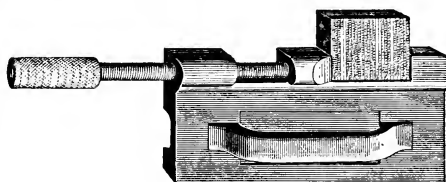

Attachment for cutting Linotype Slugs.

Saw table with shoot-board . . . . .	\$85.00
Saw table without shoot-board . . . . .	70.00
Attachment for sawing linotype slugs, extra . . . . .	15.00

**ENGRAVERS' TOOLS.**

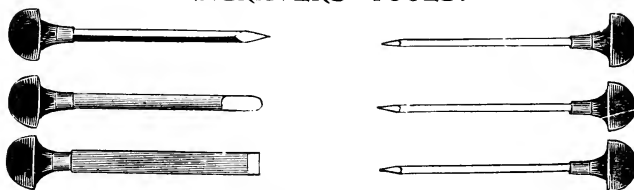

Six tools, sharpened for use, with handles, in box . . . . . \$2.50

**ENGRAVERS' WOOD.**

Prepared to order, in the best manner. Prices are net.

Boxwood, per square inch . . . . .	2 to 5 cents.
Rock Maple, per square inch . . . . .	1 and 1½ cents.
Holly-wood Face, per square inch . . . . .	1 cents.
Soft-wood Poster Tint Blocks, 27½×39¼ inches . . . . .	\$1.25 each.

**HORIZONTAL  
WROUGHT IRON STANDING  
GALLEYS.**

Made to Order.

The Wrought Iron Standing Gallies, with columns running horizontally (see cut) have iron racks and all-brass tops. The brass strips screwed on top are L-shaped, making the partitions only a little wider than column width, but leaving enough room for the fingers to lift the type, thus reducing the width of the top, making it more convenient to reach the upper rows. The columns are made to any desired length and width.

The cut on this page is an illustration of the No. 6 size, which is twelve feet long, with iron racks for 32 full-size cases.

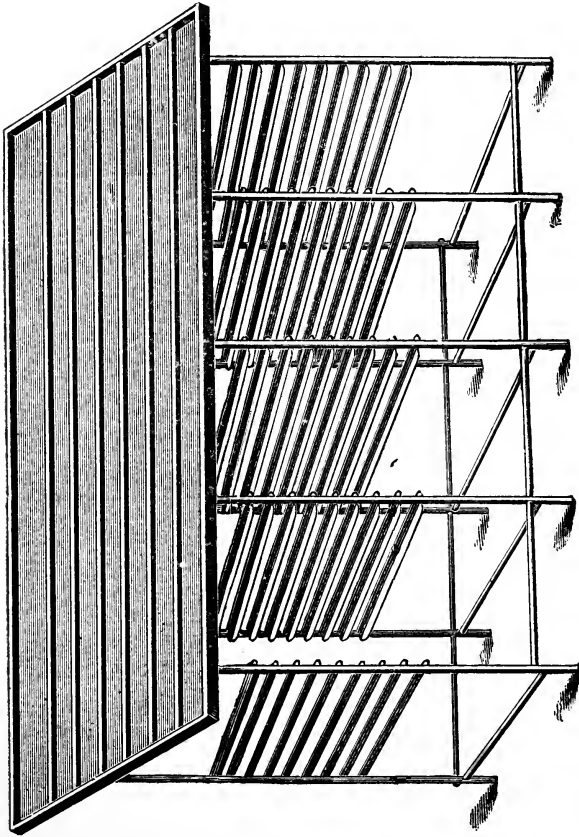

		What the Racks Hold.					
No.	Length of Rack.	5 Single Columns.	6 Single Columns.	7 Single Columns.	8 Single Columns.	9 Single Columns.	10 Single Columns.
1	5 feet.	\$54.00	\$58.00	\$62.00	\$66.00	\$70.00	\$74.00
2	6 "	70.00	75.00	80.00	85.00	90.00	95.00
3	7 "	65.00	71.00	77.00	83.00	89.00	95.00
4	8 "	80.00	86.00	92.00	98.00	104.00	110.00
5	10 "	85.00	92.00	99.00	106.00	113.00	120.00
6	12 "	95.00	104.00	113.00	122.00	131.00	140.00

**STANDING GALLEY WITH LETTER BOARDS.**

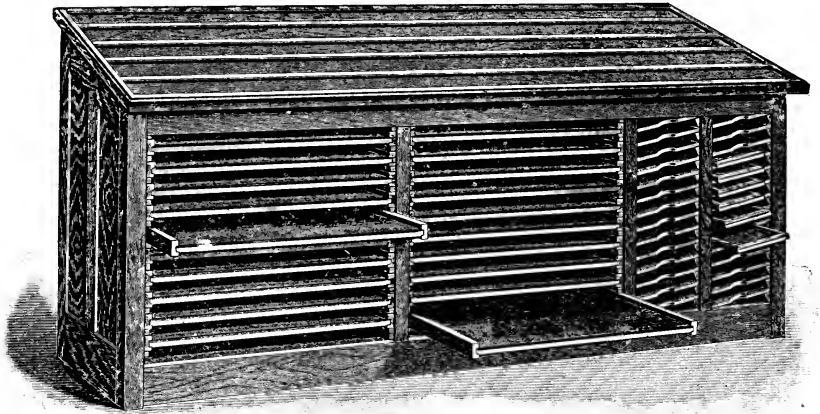

Contains 20 hard-wood letter boards, size of each  $24 \times 30\frac{1}{2}$  inches inside, and racks for 26 triple column galleys; or if galley racks are not needed, 10 letter boards, each  $24 \times 21$  inches inside, will be furnished instead at the same price. The brass-top style is covered with a single sheet of finest hard-rolled brass, and all division strips are lined with brass. Length, 8 feet; depth, 27 inches. Height in front, 3 feet; at back, 3 feet 10 inches.

Prices: unlined, wood top, \$60.00; zinc-lined top, \$80.00; brass-lined top, \$90.00.

**STANDING GALLEYS.**

See description and prices on opposite page.

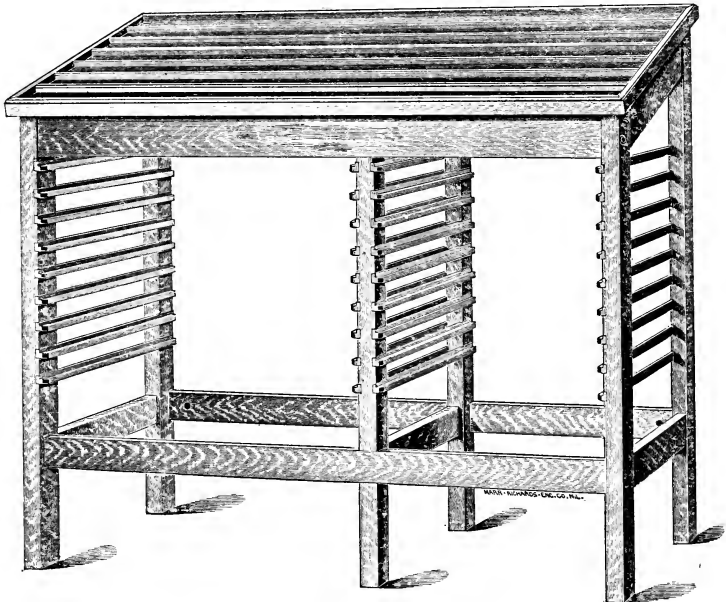

# STANDING GALLEYS.

Made to Order.

**See illustration on opposite page.** The stand is always of wood, but the tops may be of wood, zinc or brass. Buyers may have these made to any dimensions they desire, at prices proportionate to those quoted below for the sizes and styles commonly used.

The space underneath may be utilized in various ways. In place of the case racks, as shown in the cuts, galley shelves and racks or letter boards can be put in. In ordering Standing Gallies, or in sending for estimates of cost, it is necessary to be *explicit* as to measurements and other requirements.

The regular width of single columns is three inches; of double columns, six inches; but these may be varied. The column strips are made of the same material as ordered for the top.

No.	Length Over All.	Material Used on Top.	What the Racks Hold.	5 Single Columns. Top 20 ins. wide.	6 Single Columns. Top 23 1/2 ins. wide.	7 Single Columns. Top 27 ins. wide.	8 Single Columns. Top 30 1/2 ins. wide.	9 Single Columns. Top 34 ins. wide.	10 Single Columns. Top 37 1/2 ins. wide.
1	5 feet.	Hard Wood,	8 each full and two-third cases.	\$14.75	\$15.25	\$15.75	\$16.25	\$16.75	\$17.25
1A	5 "	Zinc Lined,		8 each full and two-third cases and 14 galley racks.	19.75	21.00	22.50	24.00	25.75
1B	5 "	Brass Lined,	16 full-size cases.		26.00	29.00	32.00	35.00	38.00
2	6 "	Hard Wood,		16 full-size cases and 14 galley racks.	16.00	16.55	17.10	17.65	18.20
2A	6 "	Zinc Lined,	24 full-size cases.		22.75	24.00	25.50	27.00	28.75
2B	6 "	Brass Lined,		32 full-size cases.	31.00	34.50	38.00	41.50	45.00
3	7 "	Hard Wood,	16 full-size cases and 14 galley racks.		18.80	19.45	20.10	20.75	21.40
3A	7 "	Zinc Lined,		24 full-size cases.	26.75	27.50	29.50	31.00	32.75
3B	7 "	Brass Lined,	32 full-size cases.		35.50	39.50	43.50	47.50	51.50
4	8 "	Hard Wood,		16 full-size cases and 14 galley racks.	23.50	24.25	25.00	25.75	26.50
4A	8 "	Zinc Lined,	24 full-size cases.		31.75	36.50	34.50	36.00	37.75
4B	8 "	Brass Lined,		32 full-size cases.	42.00	46.50	51.00	55.50	60.00
5	10 "	Hard Wood,	16 full-size cases and 14 galley racks.		25.25	26.25	27.25	28.25	29.25
5A	10 "	Zinc Lined,		24 full-size cases.	35.75	38.50	40.50	42.00	43.75
5B	10 "	Brass Lined,	32 full-size cases.		49.50	54.75	60.00	65.25	70.50
6	12 "	Hard Wood,		16 full-size cases and 14 galley racks.	29.50	30.65	31.80	32.95	34.10
6A	12 "	Zinc Lined,	24 full-size cases.		40.75	43.50	45.75	48.00	50.75
6B	12 "	Brass Lined,		32 full-size cases.	57.75	64.50	71.25	78.00	84.75

**WROUGHT IRON LONGITUDINAL STANDING GALLEY.**

**With All-Brass Tops.**

*These Standing Galleys are made in a substantial, workmanlike manner, entirely of brass and wrought iron. The top is covered with sheet brass, and screwed on the hard-wood top from underneath, leaving the surface perfectly smooth.*

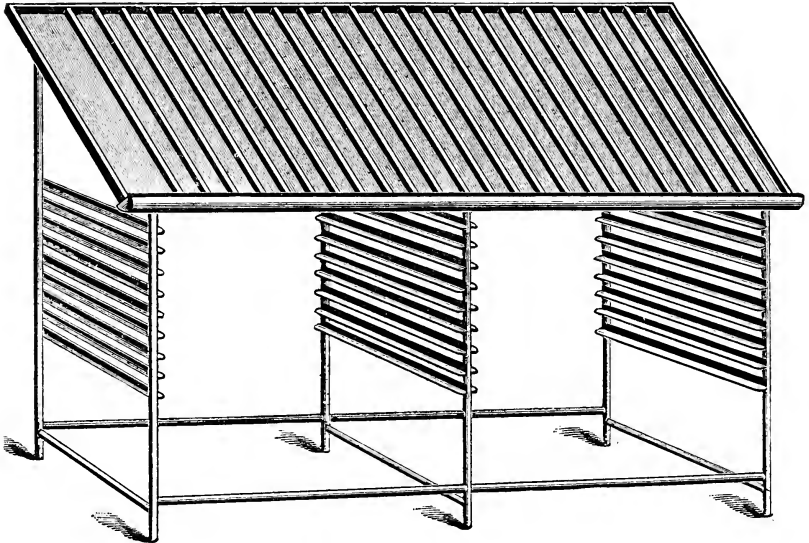

Wrought Iron Standing Galley, with All-Brass Top. This illustrates one 7 feet long and 26 inches wide.

Standing Galleys with columns running longitudinally are designed for dead matter, and are considered almost indispensable by those using them. Uniform distribution is guaranteed, as the compositor is compelled to take the type from the top, and gets it into the cases regularly; consequently the type gets an even wear, which cannot be attained by the old method. The front is provided with a channel or gutter for the water used in wetting the type to run off into a receptacle. *Any size made to order.*

Price, per single column, 26 inches deep, in banks not less than 5 feet long . . . . . \$3.50

**TYPE-HIGH GAUGE.**

Much time may be saved in the press room if the maker-up will test all electrotypes, and have those that are high or low brought to the proper height by an electrotyper, or do it himself, before the form goes to press. The wise employer should insist on the use of this Gauge.

Price, each . . . . . \$2.50

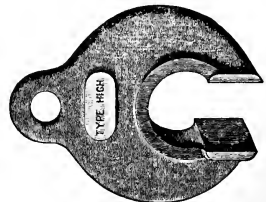

**THORNE  
TYPE-  
SETTING  
AND  
DISTRIBUTING  
MACHINE.**

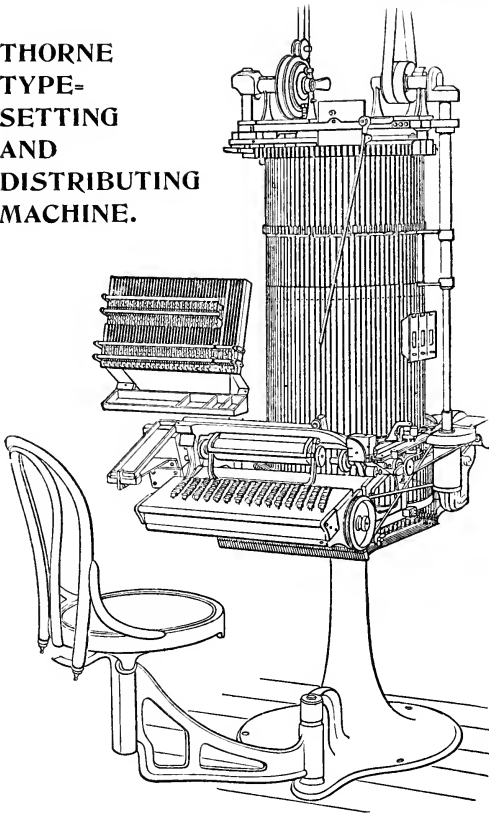

Type-setting machines, long regarded as an experiment, are now as much of a necessity in the average printing office as cylinder presses, and publishers or printers having any considerable amount of plain book or news composition cannot afford in these days of competition and hurry to rely upon slow, laborious and expensive hand composition, when this simple, reliable, and moderate-priced machine is available, which will produce the same work in a perfect manner, in half the time, and at less than half the expense of hand work.

The Thorne Type-Setting Machine, using perfect type, produces results typographically equal, if not superior, to the work of the hand compositor; so that not only are these machines now in successful use on news and periodical work, but they are likewise constantly employed in the production of books requiring composition of the most exacting character.

The processes of distribution and composition are combined in a compact and simple machine of marvelous accuracy of construction, occupying but small floor space, and requiring little more power for its operation than a sewing machine. The different processes of the work are under the instant and ready control of the operators; the distributor may be operated or stopped without interfering with the work of composition, and the setting of type may continue so long as there is type for distribution. There being no time lost in distribution, composition may be carried on continuously should occasion require it, and it is a common practice to run machines with two sets of operators night and day.

Proficiency in operating the machine is readily acquired after short practice by printers, and no machinist is required in attendance, for all working parts are made interchangeable. When a part becomes worn or damaged it can be replaced by any one of average mechanical ability. The capacity of the machine is limited only by the proficiency of the operator, and the character of the work being handled; on book work from five to six thousand ems per hour are readily distributed and set, while on news work and work of similar nature from six to nine thousand ems are produced by expert operators.

Machines are constructed to handle any one size of type from Agate to Pica, and for book work are so constructed that the measure may be changed in a minute's time. They are adaptable for use in any language, and machines are now employed by English, French, Finnish, Hebrew and German printers to set the type of newspapers, books and periodicals published in these languages. In the classes of work for which it is designed the machine will earn its cost within a few months.

Price, complete, with all fixtures, f. o. b. Hartford, Conn . . . \$1500.00

## FOR THE PRESS ROOM.

### BLANKETS FOR CYLINDER PRESSES.

FELT.				RUBBER.			
Size Bed.	Size Blanket.	Thick. Each.	Thin. Each.	Size Bed.	Size Blanket.	Regular Thickness.	Each.
17×21	19×20	\$2.75	\$1.75	17×21	19×20	Each,	\$3.00
20×25	23×24	3.25	2.00	20×25	23×24	"	4.25
21×27	25×25	3.50	2.25	21×27	25×25	"	4.75
24×30	28×28	4.00	2.75	24×30	28×28	"	5.75
25×35	29×33	5.50	3.75	25×35	29×33	"	6.50
29×42	34×40	6.25	5.00	29×42	34×40	"	8.75
32×46	38×44	8.75	6.50	32×46	38×44	"	10.50
33×50	38×47	9.75	7.50	33×50	38×47	"	11.75
36×52	42×49	11.25	9.25	36×52	42×49	"	13.25
40×54	46×53	12.25	10.00	40×54	46×53	"	17.00

### FELT BLANKETS FOR HAND PRESSES.

For 6-column newspaper . . .	\$3.00	For 8-column newspaper . . .	\$5.00
For 7-column newspaper . . .	3.75	For 9-column newspaper . . .	6.50

### FELT BLANKETS.

Width.	Thick. Per Yard.	Thin. Per Yard.	Width.	Thick. Per Yard.
36 inches	\$5.40	\$2.75	56 inches	\$8.50
40 inches	6.00	3.00	58 inches	8.75
44 inches	6.60	3.25	60 inches	9.00
48 inches	7.25	..	62 inches	9.50
54 inches	8.10	..	65 inches	9.75

### ROLLER CLOTH,

In rolls 12 yds. long by 2½ in. wide, per roll . . . . . \$5.00

### RUBBER BLANKETS.

	2-Ply 1-16-Inch Thick.	3-Ply 1-12-Inch Thick.	5-Ply ½-Inch Thick.	Tympan Rubber.
26 inches wide, per yard	\$5.00	\$6.25	\$7.25	..
32 inches wide, per yard	5.75	7.00	8.75	..
34 inches wide, per yard	6.25	7.50	9.75	..
36 inches wide, per yard	6.50	7.75	10.25	\$1.25
38 inches wide, per yard	7.25	8.50	11.25	..
40 inches wide, per yard	7.50	8.75	11.75	..
44 inches wide, per yard	8.50	10.00	13.50	..
48 inches wide, per yard	10.50	12.00	16.00	..

### TAPE.

¾-inch, per roll . . . . .	\$ .75	1-inch, per roll . . . . .	\$1.50
½-inch, per roll . . . . .	.75	1½-inches, per roll . . . . .	1.60
⅝-inch, per roll . . . . .	1.00	1¾-inches, per roll . . . . .	1.75
¾-inch, per roll . . . . .	1.25	1½-inches, per roll . . . . .	2.00

A roll of tape contains thirty-six yards.

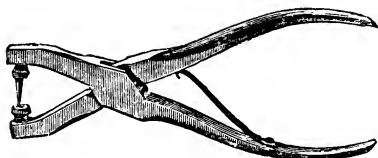

### TAPE FASTENER.

Fastens tape with eyelets, which are neatly clinched by the fastener.

Price, with box of eyelets . . \$1.25



**TYMPAN PRESSBOARDS.**

21×29 inches, each . . . . .	\$ .50	35×52 inches, each . . . . .	\$1.25
26×35 inches, each . . . . .	.75	40×56 inches, each . . . . .	1.50
29×42 inches, each . . . . .	1.00		

**METALLIC TAPE COUPLERS.**

This is a device for connecting ends of tape on presses and folding-machines, so that there will be no wear at the joined parts, as is usual on sewed ends, which wear and cause the tape to run crooked and throw paper out of register. The Metallic Tape Coupler outlasts other methods of securing the ends of tape, and keeps the tape running true. It can be put on in a few seconds by means of Parallel Pliers made for that purpose.

PRICE PER BOX OF FIFTY:

No. 1, for 1/2-inch tape . . .	\$1.25	No. 4, for 7/8-inch tape . . .	\$1.75
No. 2, for 5/8-inch tape . . .	1.50	No. 5, for 1-inch tape . . .	1.75
No. 3, for 3/4-inch tape . . .	1.50	No. 6, for 1 1/8-inch tape . . .	1.75

**Smooth Jaw Parallel Pliers** (these pliers can be used for all sizes of couplers), per pair . . . . . 1.00

**LEATHER BELTING.**

Width.	Per ft.	Width.	Per ft.	Width.	Per ft.	Width.	Per ft.
1 in. . . . .	\$ .12	2 1/2 in. . . . .	\$ .36	4 in. . . . .	\$ .60	6 1/2 in. . . . .	\$1.00
1 1/4 in. . . . .	.16	2 3/4 in. . . . .	.40	4 1/2 in. . . . .	.68	7 in. . . . .	1.08
1 1/2 in. . . . .	.20	3 in. . . . .	.44	5 in. . . . .	.76	8 in. . . . .	1.24
1 3/4 in. . . . .	.24	3 1/4 in. . . . .	.48	5 1/2 in. . . . .	.84	9 in. . . . .	1.40
2 in. . . . .	.28	3 1/2 in. . . . .	.52	6 in. . . . .	.92	10 in. . . . .	1.56
2 1/4 in. . . . .	.32	3 3/4 in. . . . .	.56				



**SCREW DRIVERS.**  
Each . . . . . \$ .75

**WRENCHES.**

8-inch . . . . .	\$ .75
12-inch . . . . .	1.00

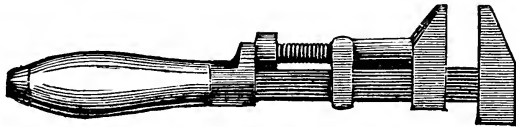

**PRINTERS' DIVIDERS.**



Useful for laying out paper, setting gauges and imposing plate forms.  
Price . . . . . \$ .85

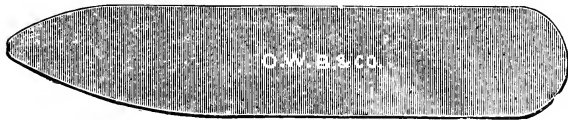

**PAPER FOLDERS.**

Also used for feeding cylinder presses.

Steel, nickel-plated, 6×1 1/8 inches, each . . . . .	\$ .50
Bone, each, 25 cents; per dozen . . . . .	2.50

**HICKORY SHOOTING STICKS.**



This is the only safe shooting stick to use on bed of a cylinder press.

Price, each, 8 cents; per dozen . . . . .	\$ .85
---	--------

PRINTERS' BRUSHES.

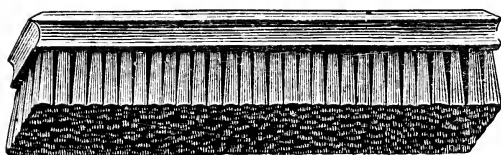

Lye Brush.

	All Bristle		Tampico	
	Per Doz.	Each.	Per Doz.	Each.
Lye Brush, medium . . . . .	\$5.00	\$ .50	\$3.50	\$ .40
Lye Brush, large . . . . .	7.00	.75	4.50	.50



Benzine Brush, with handle.

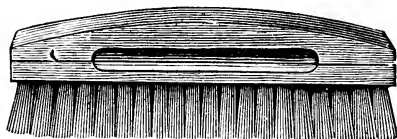

Benzine Brush, oval back.

Benzine Brush, all bristle, with handle, each . . . . .	Each. \$ .40
Benzine Brush, all bristle, oval back, genuine "pick" brush, each . . . . .	.60

LIQUID CEMENT BRUSH.

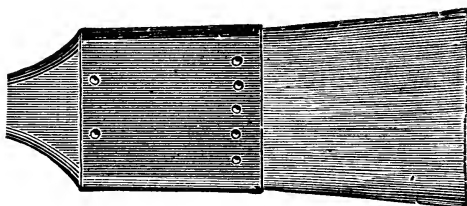

Made of French bristles, flat and double thick.

1 inch . . . . .	\$ .30
1½ inch . . . . .	.40
2 inch . . . . .	.55
3½ inch . . . . .	.75

INK SLICE.

Brass handle,  
steel blade . . \$ .75

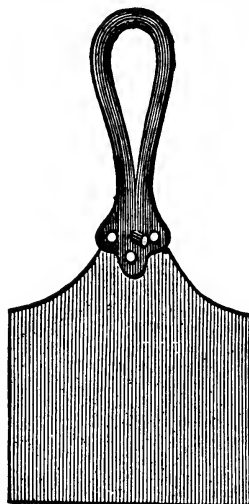

PROOF AND STEREOTYPE  
BEATING BRUSHES.

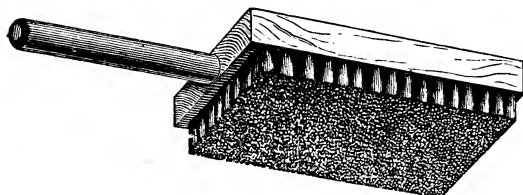

Ordinary Proof Brush, each . . . . .	\$1.50
Genuine McLaughlin Extra Stereotypers' Beating Brush, the best made, each, net . . . . .	7.00

**OVERLAY KNIFE.**

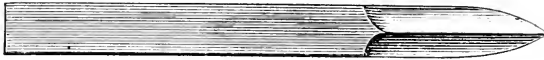

In leather case, 6 x 1/16 inch, nickeled . . . . . \$ .60

**INK KNIVES.**

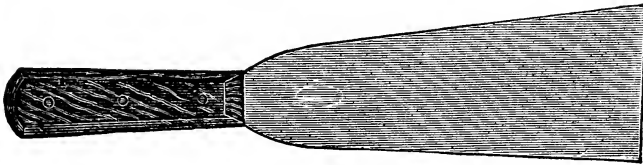

Style B.

6-inch blade, Style B . . . . . \$ .60  
 8-inch blade, Style B . . . . . 1.00  
 10-inch blade, Style B . . . . . 1.60

**PALLET INK KNIVES.**

Square end.



6-inch blade . . . . . \$ .50  
 8-inch blade . . . . . .70  
 10-inch blade . . . . . 1.00

**ST. JOHN PAPER KNIFE.**

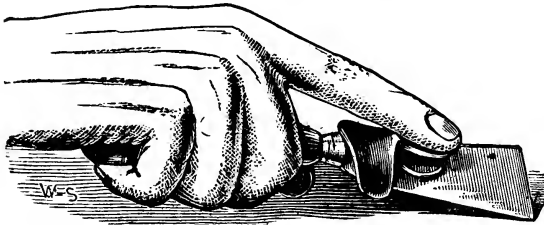

Made of fine steel and suitably pointed for cutting paper. Upon the back of the blade is fixed a broad guard, shaped to fit the finger, by which the operator is enabled to cut much faster and more easily than with the common knife.

Price . . . . . \$ .50

**TABLET KNIFE.**



Made extra thin, for separating the tablets after they are removed from the press.

Price, . . . . . \$ .50

**GAUGE PINS AND GUIDES.**

*See explanation of Nos. below.*

Original Steel Gauge Pins, Nos. 1, 2, 3, 4, per dozen . . . . .	\$ .60
Golden Steel Gauge Pins, Nos. 1, 2, 3, 4, 5, 6, per dozen . . . . .	1.40
Spring Tongue Gauge Pins, one size only, per dozen . . . . .	1.20
Flexible Side Gauge Pins (see page 835), per dozen . . . . .	.60
Perfect Register Gauge Pins, per set of three . . . . .	1.25
Screw Adjusting Gauge Pins, one size only, per set of three . . . . .	1.00
Extension Feed Guides, per pair . . . . .	1.00
Cylinder Side Guides, each . . . . .	.50
Extra Tongues for Spring Tongue, "Perfect" or Screw Adjusting Pins, per dozen . . . . .	.25
Gauge Pin Drawers (see page 835), each . . . . .	.25

**EXPLANATION OF NUMBERS.**

No. 1 gauges are 12 Points high, with lip  $\frac{1}{16}$ -inch long; No. 2, 15 Points high,  $\frac{1}{16}$ -inch lip; No. 3, 18 Points high,  $\frac{1}{16}$ -inch lip; No. 4, 12 Points high, short lip; No. 5, 15 Points high,  $\frac{1}{8}$ -inch lip; No. 6, 12 Points high,  $\frac{1}{4}$ -inch lip. All gauges with tongues are 12 Points high.

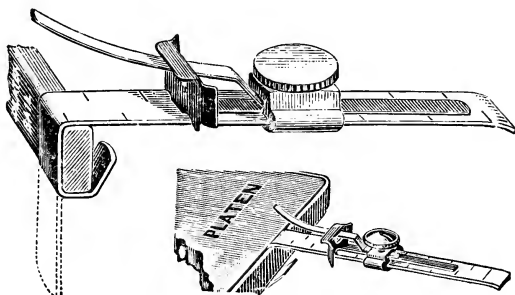

**Extension Feed Guides.**

The cuts show the method of securing the guides between platen and platen bail, so that sheets may be fed below the lower edge of a platen.



**Golden Steel Gauge Pin.**



**Original Steel Gauge Pin.**

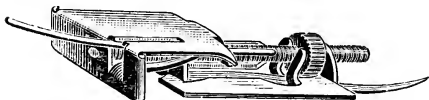

**Screw Adjusting Gauge Pin.**

The prong should be inserted a quarter inch below the feeding line and forced snugly home. The base may be secured to the tympan with paste or glue if desired. The adjustment is got by means of the screw and nut with absolute precision and without weakening the hold of the pin to tympan.



**Perfect Register Gauge Pin.**

Pastes on like a quad, has a thin steel clip which strikes into tympan and prevents sheets from slipping under gauges, and is adjustable after pasting on.

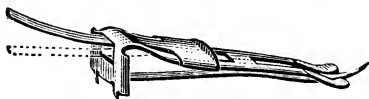

**Spring Tongue Gauge Pin.**

This is the most satisfactory gauge pin made—it meets almost every requirement of the pressman.

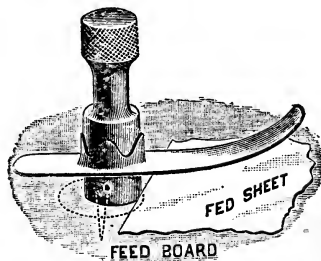

**Cylinder Side Guide.**

Secured to feed-board by the sharp point shown in outline in cut, which is placed at the side of pillar, so that hair adjustments may be got by simply turning the pillar to the desired position. The bendable brass tongue is adjustable in every direction.

**GAUGE PINS AND GAUGE PIN DRAWERS.**

*See page 834 for prices.*

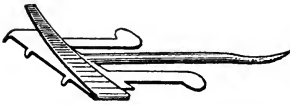

**Flexible Side Gauge Pin.**

May be placed directly under grip-  
per finger without injury to gauge or  
displacing it. The sheet is fed to the  
curved spring arm. Made of fine thin  
steel, with teeth underneath to pre-  
vent sheet from getting under gauge.

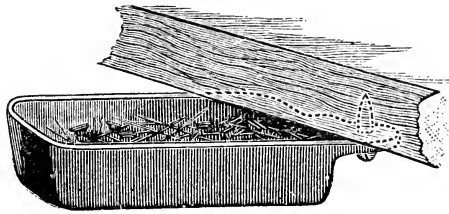

**Gauge Pin Drawer.**

Screws on under the feed-board.

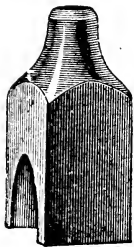

**PRESS PUNCH.**

This punch is about one thirty-second inch lower than type, and can be  
locked up in a type form, thus enabling printers to punch holes in stock at  
the same time it is printed, without extra expense. A piece of 2 Point  
brass rule should be cemented to the tympan sheet for the punch to strike  
on, and an opening left in the form opposite opening in base of punch to  
prevent it from becoming clogged. Made of best tool steel, tempered.

For  $\frac{1}{8}$ ,  $\frac{3}{16}$ , or  $\frac{1}{4}$  inch hole, each . . . . . \$1.00

**PRESS POINTS.**

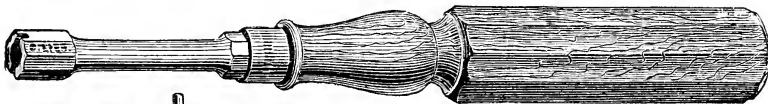

HALF SIZE.



FULL SIZE.

For inserting in wood furniture when sheets are printed for folding machine. Points are  
screwed into wood with wrench as far as the cross pin will allow, when they will be found to  
be correct height

Points, per dozen . . . . . \$ .75 | Wrench, each . . . . . .75

**ROLLER SUPPORTERS.**

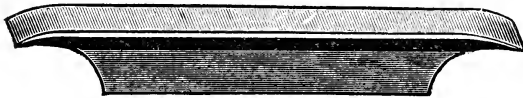

The best bearers yet devised for job presses. They only take up a quarter of an inch of  
the inside space of a chase, ease the pressure of the rollers on the form, prevent over-inking,  
equalize the impression, and save the rollers from cutting, as they are  $\frac{7}{8}$ -inch wide on top.

Chase.	Per Pair.
For 5x9 . . . . .	\$ .35
For 7x11 . . . . .	.40
For 8x12 . . . . .	.45
For 10x15 . . . . .	.50
For 11x17 . . . . .	.60
For 13x19 . . . . .	.75
For 14x20 . . . . .	.90
For 14 $\frac{1}{2}$ x22 . . . . .	.90

**AMERICAN  
COUNTING  
MACHINE.**

Has no superior for strength, accuracy, reliability. Can be set to zero, or any number, with the fingers with the greatest ease. The case may be screwed to the wall or on a table, and the lever can be set to any position. The figures are cast solid, nickel-plated, and are very legible.

Price . . . . . \$10.00



**DURANT COUNTER.**

This counter gives perfect satisfaction. It is as reliable as it is strong, durable, and attractive.

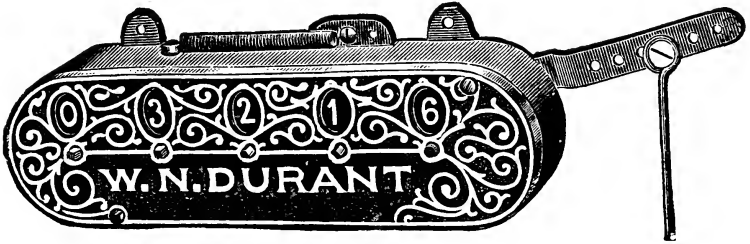

- No. 1, 4-dial, counts 10,000 . . . . . \$ 8.00
- No. 2, 5-dial, counts 100,000 . . . . . 10.00
- No. 3, 6-dial, counts 1,000,000 . . . . . 12.00
- No. 2, dial, with 4-inch gong, to give alarm at each 100 . . . . . 15.00

**DOUBLE DIAL ALARM COUNTER.**

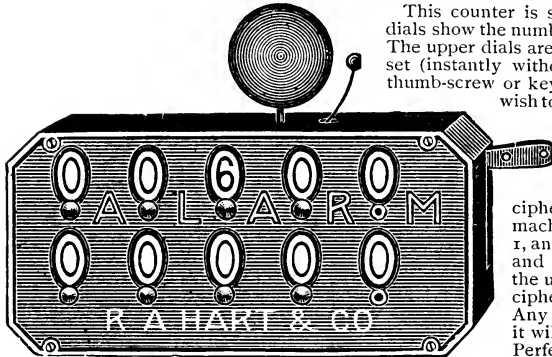

This counter is so constructed that the lower dials show the number run like the usual counter. The upper dials are the alarm device, and can be set (instantly without taking from the case, by thumb-screw or key) to any desired number you wish to print, and when that number is printed the bell will ring. To illustrate: Set the alarm on 600, if that is the number you wish to run, with lower dials on

ciphers. First revolution of the machine the lower dials will show 1, and upper dials 599 or one less, and so on until 600 is run, when the upper dials will stand at (000) ciphers and the bell will ring. Any time you look at the counter it will show how many yet to run. Perfectly simple in construction. No more springs are used than in

an ordinary counter, and all are made of best piano wire. This counter has an iron case, and very legible figures.

No. 1. Double Dial Alarm, 5x8, 1/2-in. figures, registering 100,000 . \$15.00

**ELM CITY BRONZING PAD.**



This has become an article of necessity in the press-room; saves time and bronze, and insures clean work.

- Large, 2½ × 6 inches . . . . . \$2.50
- Small, for light work, 2½ inches square . . . . . 1.50

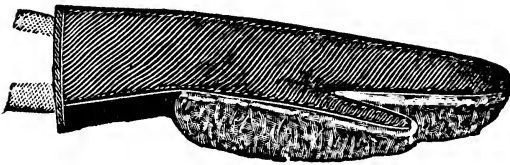

**BRONZING MITTEN.**

A convenient appliance for bronzing. Made from sheep's wool, with strong cloth back, and is impervious to bronze.

- Each . . . . . \$ .50

**ADAMSON DISC COVER.**

**Makes Copying Inks Work Easy.**

Cold iron and copying inks repel each other. To avoid trouble, slip an Adamson Disc Cover over your disc. It is made of special cloth, lined with rubber. Iron dries the ink, deadens it, wastes it. The cloth disc gives good distribution, becomes saturated with ink like a stamp pad, and saves 50 per cent. of ink. When job is done, lift off disc cover. Saves washing time, and all the ink in cover is available the next time you use it. In ordering, send the exact size of ink disc.

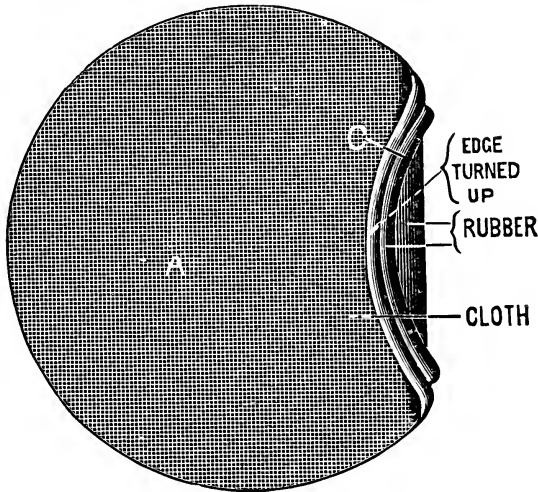

- |  |   |
|--|---|
| For 7 × 11 press, net . . . . . \$1.75 | For 12 × 18 press, net . . . . . \$2.75 |
| For 8 × 12 press, net . . . . . 1.75   | For 13 × 19 press, net . . . . . 2.75   |
| For 9 × 13 press, net . . . . . 1.75   | For 14 × 20 press, net . . . . . 3.00   |
| For 10 × 15 press, net . . . . . 2.25  | For 14½ × 22 press, net . . . . . 3.25  |
| For 11 × 17 press, net . . . . . 2.75  |   |

*Send exact size of disc when ordering.*

**SUCCESS SAFETY BENZINE CAN.**

**Made of Brass.**

This is a self-closing can. The flow of the fluid is regulated by pressure of the fingers upon the circular plate on the nozzle, and the valve operated by this pressure is so constructed that the flow can be regulated from one drop to a full stream.

The hands do not come in contact with the fluid. This can is of superior construction.

Quart can . . . . .	\$ .75
Gallon can . . . . .	2.00



**UNION SAFE BENZINE CAN.**

This is patterned after the original benzine can, with the addition of a circular plate around the head, near the vent, by means of which the valve is opened without wetting the fingers. When pressure is removed it closes automatically. The head is attached to the can with a chain, so that it cannot be lost when unscrewed for the purpose of filling with benzine. Made of tin, enameled red.

Holds one quart, each . . . . . \$ .75



**UNION STORAGE CAN.**

**For Holding Benzine or Oils.**

It is strongly made of galvanized iron and is self-closing. There can be no evaporation, and no fluid can be spilled until the nozzle is opened by means of the spring. A very necessary article in all printing offices which are permitted to have one or more gallons of benzine on the premises.

Quite a saving in cost of benzine and oils will be realized by purchasing in the quantities held by these storage cans, besides avoiding the inconvenience of sending out at frequent intervals to get the ordinary benzine can filled up.

1-gallon can . . . . .	\$2.00
3-gallon can . . . . .	2.50
5-gallon can . . . . .	3.00





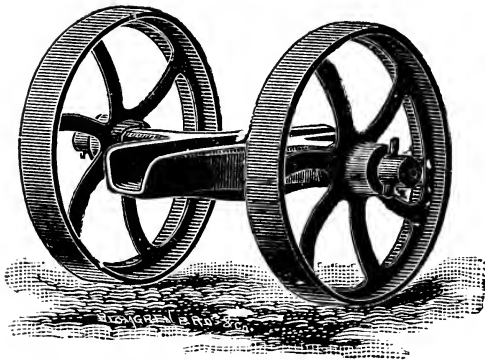

**FORM TRUCK.**

Both the Form Trucks listed below are of malleable iron. The Union Form Truck is painted red.

The use of a form truck should be insisted on in every pressroom of any size, not only because it is a time saver, but because sliding chases along the floor is a source of frequent accidents.

- Iron tire . . . . . \$3.00
- Union Form Truck, with rubber tire . . . . . 5.00

**ROLLER COMPOSITION KETTLE.**

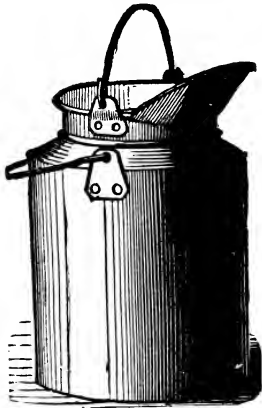

Consists of two separate kettles, the inner one to hold the composition, the outer to hold water, which prevents the composition from burning. Made of heavy tin, with copper bottom to the water kettles.

- 1 gallon, net . . . \$3.50
- 2 gallons, net . . . 5.00
- 3 gallons, net . . . 6.50

Other sizes made to order.

**ROLLER COMPOSITION.**

We recommend the use of the best compositions only.

Per lb.

- Bingham's Standard . . . \$ .35
- Bingham's Durable . . . .50
- Gem, for Northwest . . . .40

**HAND ROLLERS.**

When complete rollers are ordered, we furnish them with the best roller composition. There is no economy in cheap roller composition.

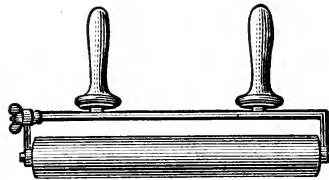

	Frame and Handle.	Roller Complete.	Extra Stock.
6 inches, 1 handle . . .	\$1.25	\$1.85	\$ .40
8 inches, 1 handle . . .	1.50	2.30	.40
10 inches, 1 handle . . .	1.75	2.75	.60
12 inches, 1 handle . . .	2.00	3.20	.60
14 inches, 2 handles . . .	2.25	3.65	.70
16 inches, 2 handles . . .	2.50	4.10	.70
18 inches, 2 handles . . .	2.75	4.55	.80
20 inches, 2 handles . . .	3.00	5.00	.80
24 inches, 2 handles . . .	3.25	5.65	1.00
26 inches, 1 handle . . .	3.75	6.35	1.15
30 inches, 1 handle . . .	4.50	7.50	1.25
36 inches, 1 handle . . .	5.00	8.60	1.40
40 inches, 1 handle . . .	5.50	9.50	1.50
44 inches, 1 handle . . .	6.00	10.40	1.60
50 inches, 1 handle . . .	6.50	11.50	. .
54 inches, 1 handle . . .	7.00	12.40	. .

**PRICES FOR CASTING JOB PRESS ROLLERS.**

	Size Press	Each.
Eighth Medium . . .	7 × 11 . . . . .	\$ .40
Eighth Medium . . .	8 × 12 . . . . .	.40
Eighth Medium . . .	9 × 13 . . . . .	.45
Quarto Medium . . .	10 × 15 . . . . .	.80
Quarto Medium . . .	11 × 17 . . . . .	1.00
Quarto Medium . . .	12 × 18 . . . . .	1.00
Half Medium . . . .	13 × 19 . . . . .	1.00
Half Medium . . . .	14 × 20 . . . . .	1.10
Half Super-Royal . .	14½ × 22 . . . . .	1.25

**MAHOGANY STEREOTYPE BLOCKS.**

*See page 841 for sizes and prices.*

These Blocks are made of the best San Domingo mahogany, thoroughly seasoned, and are first-class in every detail. All blocks are made to order at short notice.

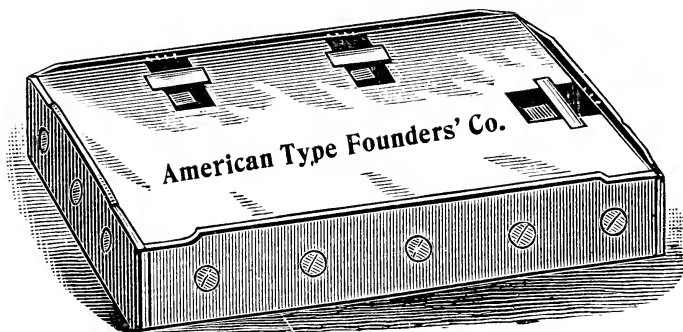

New Style Block, with Patent Side and End Hooks.

**Important Points.**—Do not order a set of blocks, nor make up a form of patent blocks for press, until you know the exact size of chase that must hold the blocks, and the thickness and position of its cross-bars. Ascertain also the exact size of paper for which the blocks are intended, and whether the leaves of paper, after printing, are to be cut or uncut, and to be sewed or stitched. In making up blocks, if paper is to be uncut and sewed, allow nothing for loss by waste on the fore edge; if it is to be side-stitched and trimmed, make suitable allowance for margin that will be concealed by wire stitching in binding.

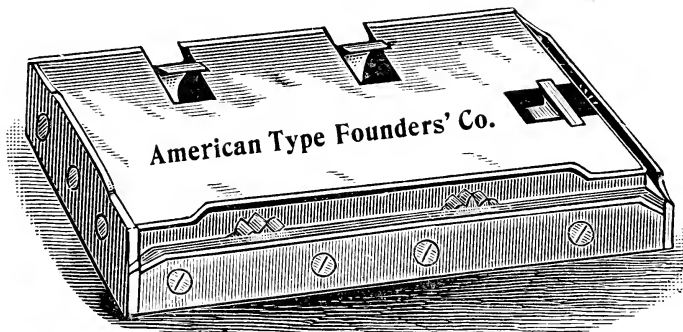

Improved Plain Old Style Block, with Patent End Hook.

To get the price of blocks with head brass, but no end hook, take the price of the next largest size in Price-List on opposite page.

Steel Pinions, each . . . . .	\$ .15
Hooks . . . . .	.10

**RATCHETS FOR STEREOTYPE BLOCKS.**

Brass, each . . . . .	\$ .50
Steel, each . . . . .	.75

MAHOGANY STEREOTYPE BLOCKS FOR CYLINDER AND PLATEN PRESSES.

See page 842 for Iron Stereotype Blocks. Blocks for Platen Presses have no End Hooks.

SIZES.	Outside Dimensions of Blocks.	Size of Largest Plate including Bevel.	Size of Smallest Plate including Bevel.	No. of Side Hooks.	No. of End Hooks.	FOR CYLINDERS.		FOR PLATENS.		Proper Number of Blocks to Work a Sheet of Paper.
						Imp. Plain Old Style.	Patent New Style.	Imp. Plain Old Style.	Patent New Style.	
Folio—										
Imperial . . .	16 × 22½	15½ × 21½	14¾ × 21¼	4	3	\$7.25	\$8.50	\$5.00	\$6.25	4 blocks to 33 × 46
Super-Royal . .	13½ × 21½	12½ × 20½	12¼ × 20¾	4	3	6.80	7.95	4.55	5.70	2 " 22 × 28
Royal . . . . .	12½ × 19½	11½ × 18½	11¼ × 18¾	4	3	6.40	7.45	4.20	5.25	4 " 26 × 40
Medium . . . . .	11½ × 18½	10½ × 17½	10¼ × 17¾	4	3	6.10	7.00	3.90	4.80	4 " 24 × 38
Quarto—										
Imperial . . . .	11 × 16	10½ × 15½	9¾ × 14¾	4	2	5.30	6.10	3.75	4.50	8 " 33 × 46
Super-Royal . .	10½ × 13½	9½ × 12½	9¼ × 12¾	3	2	4.50	5.25	3.10	3.75	4 " 22 × 28
Royal . . . . .	9½ × 12½	8½ × 11½	8¼ × 11¾	3	2	4.25	4.90	2.95	3.50	8 " 26 × 40
Medium . . . . .	9 × 11½	8½ × 10½	7¾ × 10¾	3	2	4.00	4.60	2.80	3.30	8 " 24 × 38
Octavo—										
Imperial . . . .	7¾ × 11	7½ × 10½	6½ × 9¾	3	1	3.30	3.80	2.65	3.10	16 " 33 × 46
Super-Royal . .	6½ × 10½	5½ × 9½	5¼ × 9¾	3	1	3.15	3.60	2.50	2.90	8 " 22 × 28
Royal . . . . .	6 × 9½	5½ × 8½	4¾ × 8¾	3	1	3.00	3.40	2.40	2.75	16 " 26 × 40
Medium . . . . .	5½ × 9	4½ × 8½	4¼ × 7¾	3	1	2.85	3.25	2.30	2.60	16 " 24 × 38
Demy . . . . .	5¼ × 7¾	4½ × 7½	4 × 6½	3	1	2.70	3.10	2.20	2.45	32 " 33 × 46
Duodecimo—										
Broad . . . . .	5¼ × 6¾	4½ × 6¾	4 × 5½	2	1	2.05	2.45	1.65	1.90	24 " 23 × 41
16mo—										
Super-Royal . .	5 × 6½	4½ × 5½	3¾ × 5¼	2	1	1.95	2.30	1.50	1.70	16 " 22 × 28
Medium . . . . .	4½ × 6	3½ × 5½	3¼ × 4¾	2	1	1.85	2.15	1.40	1.60	32 " 26 × 40
Demy . . . . .	3¾ × 5¼	3½ × 4½	2½ × 4	2	1	1.75	2.00	1.30	1.50	32 " 23 × 33
18mo—										
Medium . . . . .	3½ × 5¾	2½ × 5½	2¼ × 4½	2	1	1.75	2.00	1.30	1.50	18 " 19 × 24
32mo—										
Super-Royal . .	3 × 5	2½ × 4½	1¾ × 3¾	2	1	1.65	1.85	1.20	1.40	32 " 22 × 28

**CAUTION—To Avoid Errors.** In sending orders, give the size of each block outside, and also the size of largest and smallest plate to be worked, measuring the back of the plate; or add ¼ of an inch to the printing matter, as follows, viz.: if the matter is 3 x 5, the blocks should be 3¼ x 5½ outside, the bevel on the plate being about 1/8. The hook and pinion will take ¾ with a little allowance for taking the plate free. All blocks are made ¾ inch thick, unless otherwise ordered.

**IRON STEREOTYPE BLOCKS.**

Made only in New Style, as per illustration on page 840.

CAUTION.—Before ordering iron blocks, read the directions for ordering and ascertaining dimensions of mahogany blocks on pages 840 and 841, which also apply to iron blocks. There are numerous chances for errors in ordering blocks. All blocks are made to order at customer's risk, as blocks are never carried in stock.

The dimensions of smallest and largest plates, and number of blocks required to a sheet, given on page 841 for mahogany blocks, also apply to iron blocks.

SIZES.	Outside Dimensions of Blocks.	No. of Side Hooks.	* No. of End Hooks.	Patent Iron for Platen Presses.	Patent Iron for Cylinder Presses.
<b>Folio :</b>					
Imperial . . . . .	16 × 22½	4	3	\$16.00	\$21.00
Super-Royal . . . . .	13½ × 21½	4	3	15.00	19.50
Royal . . . . .	12½ × 19½	4	3	14.00	18.25
Medium . . . . .	11½ × 18½	4	3	13.00	17.25
<b>Quarto :</b>					
Imperial . . . . .	11 × 16	4	2	12.00	15.00
Super-Royal . . . . .	10½ × 13½	3	2	10.50	13.50
Royal . . . . .	9½ × 12½	3	2	10.00	12.75
Medium . . . . .	9 × 11½	3	2	9.50	12.25
<b>Octavo :</b>					
Imperial . . . . .	7¾ × 11	3	1	9.00	10.75
Super-Royal . . . . .	6½ × 10½	3	1	8.50	10.00
Royal . . . . .	6 × 9½	3	1	8.00	9.50
Medium . . . . .	5½ × 9	3	1	7.75	9.00
Demy . . . . .	5¼ × 7¾	3	1	7.50	8.50

\* Iron Blocks for platen presses have no end hooks.

**STEREOTYPE SECTIONAL METAL BLOCKS**

Consist of metal sections, made up of pieces

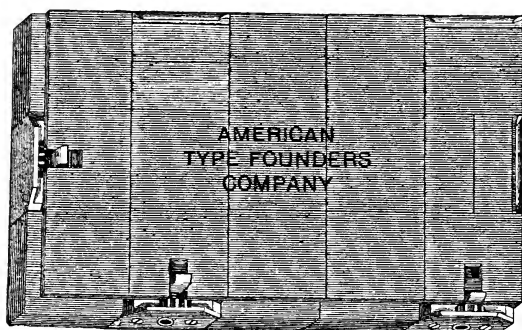

2×4, 2×8, 4×4, 4×8, and 8×8 ems Pica. Hooks are inserted in the largest sections, which may be arranged on any part of the block, and can be adapted for bed and platen or cylinder presswork. With an assortment of the sections or furniture, the printer may, by a proper combination, prepare a set of blocks to take on a page of any size. To extend size of sectional block, in case there is a shortage of sections, metal

furniture not exceeding two ems Pica wide may be used.

Sections with hook, each . . . . .	\$1.10
Brass catches, each . . . . .	.15
Sections or furniture, per pound . . . . .	.25

## GERMAN PRINTING INKS.

These inks are made by one of the most extensive ink manufacturers in the world, and have a world-wide reputation for quality and uniformity. We use them exclusively on our own specimen printing. Inks for special work and to match all colors furnished to order expeditiously.

### SUPERIOR NEWS INKS.

	5 and 10 lb. cans.	28 and 56 lb. cans.	112 lb. barrels.	224 lb. barrels.	450 lb. barrels.
For hand presses,	per lb. . . . \$ .20	\$ .15			
For flat-bed presses	" . . . . .18	.14	\$ .13	\$ .12	\$ .12
For perfecting presses,	" . . . . .		.13	.12	.12

*N. B.—All inks listed at \$1.50 and over supplied in ¼ lb. tubes if so ordered, but at a lesser discount than is allowed on inks sold in cans.*

### BLACK INKS.

	Per lb.
Book Ink, N . . . . .	\$ .25
Brilliant Black, M, book . . . . .	.50
Brilliant Black, M, job . . . . .	.50
Brilliant Black, L, book . . . . .	.75
Brilliant Black, L, job . . . . .	.75
Fine Book and Job Ink, K . . . . .	1.00
Columbian Black, H, for half-tones . . . . .	1.00
Insurance Policy Black . . . . .	1.00
Union Black, I, job . . . . .	1.50
Union Black, I, for half-tones . . . . .	1.50
Fine Job and Cut Ink, G . . . . .	2.00
Fine Cut Ink, G, for half-tones . . . . .	2.00
Gloss Black . . . . .	2.00
Fine Union Black, F, cut and job . . . . .	3.00
Fine Union Black, F, for half-tones . . . . .	3.00
Extra Fine Union Black, E, cut and job . . . . .	5.00
Extra Fine Union Black, E, for half-tones . . . . .	5.00
Blue Black, dark . . . . .	1.50
Bronze Blue Black, light . . . . .	2.50
Bronze Blue Black, medium . . . . .	2.00
Fine Green Black . . . . .	2.00

### RED INKS.

	Per lb.		Per lb.
Paris Lake . . . . .	\$2.50	Geranium Carmine, 00 . . . . .	\$10.00
Chinese Vermilion . . . . .	2.00	Geranium Carmine, 1 . . . . .	8.00
Hamburg Red . . . . .	2.50	Geranium Lake, dark . . . . .	5.00
Brilliant Lake, B . . . . .	1.50	Geranium Lake, medium . . . . .	5.00
Brilliant Lake, G, Lake shade . . . . .	1.50	Geranium Lake, light . . . . .	5.00
Deep Red . . . . .	1.00	Madder Lake . . . . .	10.00
Brilliant Red, light . . . . .	1.00	Bronze Carmine . . . . .	5.00
Granat Vermilion . . . . .	1.00	Levantine Red . . . . .	5.00
Poster Red . . . . .	.50	Claret Color . . . . .	5.00
Poster Orange . . . . .	.50	Nassau Lake . . . . .	4.50
		Rose Lake, dark . . . . .	4.00
		Rose Lake, medium . . . . .	3.00
		Rose Lake, light . . . . .	3.00
		Deep Cherry . . . . .	4.00
		Crimson Lake . . . . .	4.00
		Carmine Vermilion . . . . .	4.00
		Brilliant Red, dark . . . . .	3.00
		Brilliant Red, medium, Lake shade . . . . .	2.00



**GERMAN PRINTING INKS—Continued.**

**BLUE INKS.**

	Per lb.		Per lb.
Blue Lake, dark . . . . .	\$5.00	Prussian Blue . . . . .	\$2.50
Blue Lake, light . . . . .	5.00	Brussels Blue . . . . .	2.50
Milori Blue . . . . .	3.00	Oriental Blue . . . . .	2.50
Ultramarine, dark . . . . .	3.00	Marine Blue . . . . .	2.00
Ultramarine, light . . . . .	1.50	Peacock Blue . . . . .	4.00
Imperial Blue . . . . .	3.00	Deep Blue . . . . .	1.00
Bronze Blue, No. 1 . . . . .	2.50	Poster Blue . . . . .	.50
Bronze Blue, No. 2 . . . . .	2.50		

**GREEN INKS.**

Brilliant Green, light . . . . .	\$5.00	Silk Green, dark . . . . .	\$2.00
Brilliant Green, deep . . . . .	5.00	Silk Green, medium . . . . .	2.00
Victoria Green, dark . . . . .	5.00	Silk Green, light . . . . .	1.50
Victoria Green, light . . . . .	4.00	Olive Green . . . . .	2.00
Viridin Blue . . . . .	5.00	Poster Green, light . . . . .	.50
Bronze Green . . . . .	4.00	Poster Green, dark . . . . .	.50
Green Lake . . . . .	3.00		

**BROWN INKS.**

Brown Lake . . . . .	\$4.00	Terra di Sienna . . . . .	\$2.00
Photographic Brown . . . . .	3.00	Mahogany Brown . . . . .	2.00
Virginia Brown . . . . .	3.00	Ochre . . . . .	1.00
Bismarck Brown . . . . .	3.00	Poster Brown . . . . .	.50
Velvet Brown . . . . .	2.50		

**YELLOW INKS.**

Chrome Yellow, deep . . . . .	\$2.00	Persian Yellow . . . . .	\$2.00
Chrome Yellow, light . . . . .	2.00	Sulphur Yellow, dark . . . . .	2.00
Chrome Orange . . . . .	2.00	Yellow, medium . . . . .	1.00
Zinc Yellow . . . . .	2.00	Poster Yellow . . . . .	.50

**PURPLE INKS.**

Violet Lake, reddish . . . . .	\$10.00	Brilliant Violet . . . . .	\$4.00
Violet Lake, bluish . . . . .	8.00	Violet No. 1 . . . . .	4.00

**WHITE INKS.**

Extra Fine Body White (prints white) . . . . .	\$1.50
Fine White, for tints . . . . .	1.00

**TINT INKS.**

Any shade . . . . .	\$1.00
---------------------	--------

**COPYABLE INKS.**

Purple . . . . .	\$5.00	Blue . . . . .	\$5.00
Black . . . . .	5.00	Scarlet . . . . .	5.00
Red . . . . .	5.00	Green . . . . .	5.00

**BRONZE SIZE.**

Yellow . . . . .	\$1.50	White, for silver bronzes . . . . .	\$1.50
------------------	--------	-------------------------------------	--------

**REDUCING VARNISHES**

**For Reducing Colored and Fine Black Inks.**

	Per lb.	Per gal.
Pure Linseed, bleached, A, very soft . . . . .	\$ .50	\$2.25
Pure Linseed, bleached, B, soft . . . . .	.55	2.25
Pure Linseed, bleached, C, medium . . . . .	.60	2.50

**Ordinary, for Reducing Black Inks.**

Ordinary . . . . .	\$ .30	\$1.00
--------------------	--------	--------

EVERYTHING FOR THE PRINTER

**GLOSS VARNISHES.**

Transparent Gloss Varnish, for mixing into inks . . . . .	Per lb.	\$1.50
Body Gloss Varnish, for printing over black and colored inks . . . . .		1.50

**DRYERS.**

Body Dryer, will not reduce consistency or body of inks . . . . .	\$1.50
Fluid Dryer . . . . .	1.50

NOTE—From one to two per cent. of above dryers can be safely used in colored inks, and from three to eight per cent. in black inks.

**BRONZE POWDERS.**

	Per oz.	Per lb.
Extra Fine Brilliant Rich Gold No. 1 . . . . .	\$ .40	\$3.50
Extra Fine Brilliant Pale Gold No. 1 . . . . .	.45	4.50
Extra Fine Brilliant No. 1, Crimson, Copper, Fire or Green . . . . .	.45	4.50
Extra Brilliant Rich "Electra" Gold No. 2 . . . . .	.35	3.00
Extra Brilliant Pale "Electra" Gold No. 2 . . . . .	.40	4.00
Brilliant Pale Gold No. 3 . . . . .	.25	2.00
Brilliant No. 3, Crimson, Copper, Fire or Green . . . . .		3.00
Rich or Pale Gold, grade A . . . . .		1.00
Pale Gold, grade B . . . . .		1.25
Silver No. 1 . . . . .	.50	5.00
Silver No. 2 . . . . .	.40	3.50
Silver No. 3 . . . . .	.25	2.50
Aluminum . . . . .		4.00
Patent Bronzes, all colors . . . . .		4.00

Views of Factories in which above Inks are Made.

Every Ingredient used in High-class Inks Made in these Factories.

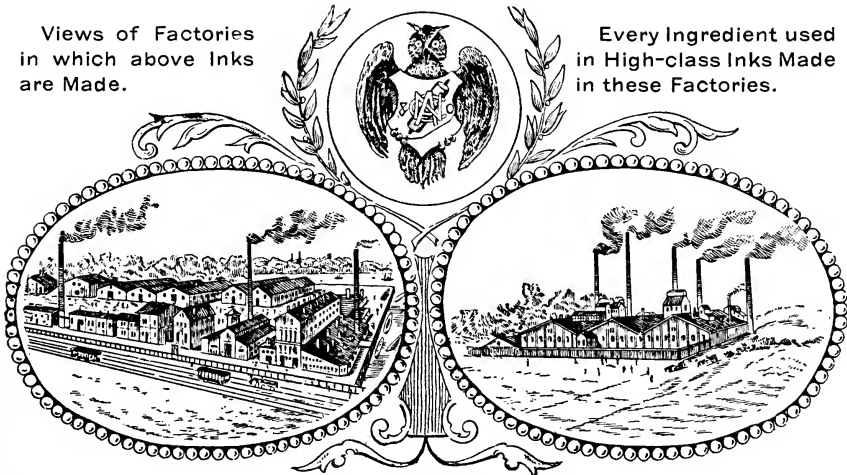

**INKOLEUM.**



THE Printers' Wonder

Patent Dec. 6, 1886.  
Patent Sept. 13, 1887.  
Patent Nov. 21, 1887.  
Patent Feb. 27, 1888.

**INKOLEUM**

A COLORLESS REDUCER For Printing Inks.

Trade-Mark Registered

A liquid preparation of world-wide fame for reducing and refining printing inks without impairing the color. It makes intractable inks work smoothly on discs, cylinders and rollers, and, mixed with caked inks, makes them useful again.

Per bottle, half-pound . . . . .	\$ .50
----------------------------------	--------

**CHESAPEAKE ECONOMY COMPOUND.**

The Effective Ink Reducer for both Lithographic and Letterpress Inks



**IT IS PURE.**—Chesapeake Economy Compound is absolutely free from mineral petroleum products or acids of any kind, and is perfectly safe. Varnishes may be added, if required.

**IT HELPS INKS.**—Any kind or color of ink mixed with Chesapeake Economy Compound will not dry on forms or rollers, and will not skin when exposed to the air. Upon being mixed with ink, Economy Compound be-

comes thoroughly identified with it, and with less weight of ink a solid, sharp print is obtained. Inks mixed with Economy Compound will cover 30 per cent. more paper than if used without it.

**IT PREVENTS TROUBLE.**—Coated and surface papers will not pull if printed with ink mixed with Economy Compound, and the use of the Compound tends to prevent off-set and to make inks dry quicker on paper. It is not necessary, as a rule, to wash up rollers at night when inks are mixed with Economy Compound, as the inks will not dry on rollers. Economy Compound keeps lithographic stones in good condition, and inks mixed with it lift well from the stone.

1-pound cans . . . . .	\$ .75	25-pound kegs . . . . .	\$13.75
5-pound cans . . . . .	3.25	50-pound kegs . . . . .	25.00
10-pound cans . . . . .	6.00		

**A FEW OPINIONS.**

*The Pioneer Press Co., St. Paul, Minn.:* "Ship us 50 pounds Economy Compound, same as furnished heretofore."

*Excelsior Printing Co., Chicago:* "It gives the ink a gloss, and the ink does not off-set so much nor pull the surface off the paper. It is especially good for colored inks."

*P. F. Pettibone & Co., Chicago:* "We have been using Economy Compound in our press-room for some months, and find it a very fine article indeed."

**EUREKA TYPE WASH.**

The most effective powder preparation for removing ink from type rollers and plates. Does not injure brushes, corrode type, nor hurt the hands. Directions on every package. While its action is gentle, it is quite as effective for cleaning as the most powerful lye. One pound of powder will make eight gallons of washing fluid.

1-pound cans, each . . .	\$ .20
5-pound cans, each . . .	.75
10-pound cans, each . . .	1.25
50-pound tubs, each . . .	5.00





**HERCULES LIQUID OVERLAY.**

A substitute for paper overlays, giving a finer, quicker make-ready, and saving lots of time and tedious work. It is put on thinly with a camel's-hair brush, and the first application should be allowed to dry before putting on another, if the first is not heavy enough. It dries very quickly. If the Liquid Overlay is put on too thickly, the overlay is reduced by scraping it with fine emery cloth.

4-ounce bottle, net . . . . . \$1.25 | 8-ounce bottle, net . . . . . \$2.00  
Full directions with each bottle.

**BURBANK'S  
EMBOSSING COMPOSITION.**

This is an approved and satisfactory liquid chemical preparation for making counter dies for embossing, which, after exposure for a few minutes to light and air, hardens into a stone-like substance, making a perfect counterpart.

It is easily applied, according to directions printed on every can, and greatly simplifies and cheapens the process of embossing.

Price, net . . . . . \$ .75

**LAWLOR'S  
"EMBOSSING MADE EASY."**

This book explains lucidly and gives directions for several processes of embossing. It is the standard work on the subject.

Price, net . . . . . \$1.00



**"BENTROVATO."**

[TRADE MARK.]

**Dispels Electricity from Paper on Printing Presses.**

A chemical fluid preparation which, applied in a small quantity to the tympan sheet by means of a sponge, cloth or cotton waste, effectually dispels the electricity generated in cylinder presses—a difficulty which results in serious losses to printers.

In all offices where there is a tendency toward this trouble, a bottle of "Bentrovato" will prove as valuable as the proverbial "stitch in time."

"Bentrovato" is used in a majority of the larger printing offices throughout the United States.

*American Type Founders' Co.:* Please send me at once by American Express one bottle of "Bentrovato." I should not like to be without it, even if it cost \$50 per bottle. Our devil knocked over the first bottle you sent us. I bought it with no faith, simply because I was willing to try anything. Our paper was as if possessed by ten thousand devils. The trouble ended at once and completely with the use of the "Bentrovato."—WALTER B. SHEPPARD, publisher of the Pan Yan Democrat (founded in 1818).

Per bottle, net . . . . . \$ .50

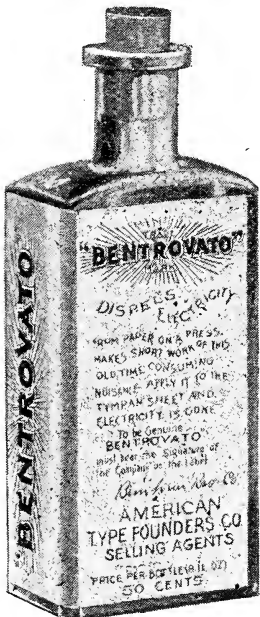

**INK AND  
ROLLER  
CABINETS.**

A very necessary article of printing office furniture. The use of it will result in a saving of ink and rollers, which will speedily pay for the cost of cabinet.

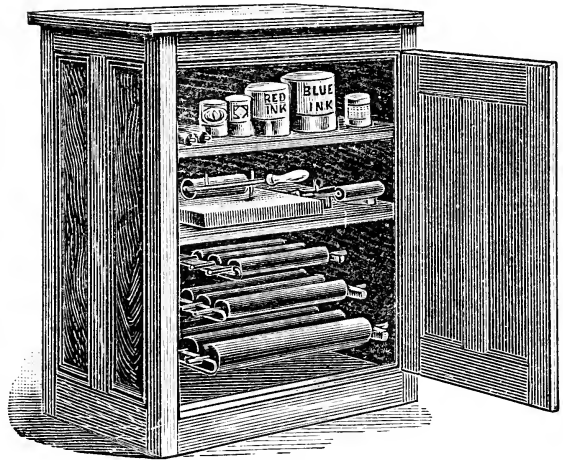

- No. 1, with shelf for ink, shelf for brayer and ink slab, and bracket to hold 6 eighth and 6 quarto rollers . . . . . \$ 6.50
- No. 2, with shelf for ink, shelf for brayers and ink slabs, and brackets for 6 each eighth, quarto, and half-medium rollers . . . . . 9.50
- No. 3, with shelf for ink, shelf for brayers and ink slabs, and brackets to hold 12 each eighth, quarto, and half-medium rollers . . . . . 13.00

**MILLER PERFECT GRIPPER PERFORATOR.**

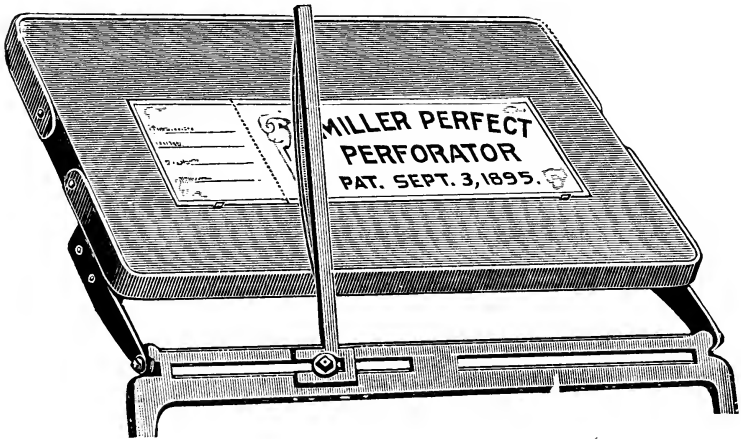

Made of steel, to attach to any platen press. Perforates neatly and cleanly while printing. Does not interfere with impression. There is a half elliptic spring which pushes the perforated sheet off the perforating knife.

- For Eighth-Medium Press, net . . . . . \$5.00
- For Quarter-Medium Press, net . . . . . 6.00
- For Half-Medium Press, net . . . . . 7.00

When ordering it is necessary to state name and size of press.

WETTER NUMBERING MACHINE.

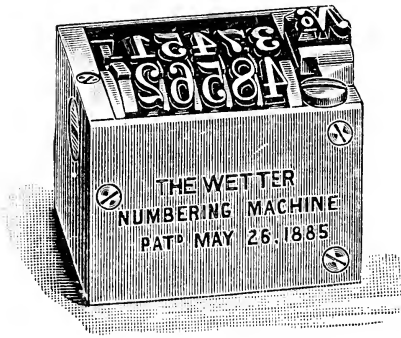

Actual size Style J.

Adapted to the requirements of every printer. Permits printing and numbering at one impression. Can be used on any make of press. Numbers automatically from the unit to its full numerical capacity. It can be used with or *without* the character "No." Other characters can be used to either precede or follow the figures. Produces figures as clean, smooth and distinct as a copper-plate. The following figures can be supplied in machines of five, six and seven wheels.

J 1234567890    K 1234567890

The 5-wheel style J machine occupies a surface space of  $\frac{7}{8}$  inches in width by  $1\frac{1}{4}$  inches in length.

J or K, five wheels, numbering up to	99,999 . . . . .	\$25.00
J or K, six wheels, numbering up to	999,999 . . . . .	28.00
J or K, seven wheels, numbering up to	9,999,999 . . . . .	31.00

Unless otherwise ordered, 5-wheel style J machine will be sent.

PRINTERS' TRUCKS.

Lay Printed Sheets on Trucks and not on the Floor, and thus Save Cost and Loss in Handling.

With platform 34 inches wide by 50 inches long, 11 $\frac{3}{4}$  inches high . . . . . \$16.00

Special prices in quantities. Other sizes at proportionate rates.

Made of hard wood 1 $\frac{3}{4}$  inches thick, bolted, varnished. Center wheels, 9 $\frac{3}{4}$  inches diameter, 3 inches face. Caster wheels, 4 $\frac{3}{4}$  inches diameter, 1 $\frac{1}{4}$  inches face. Steel axle, 1 $\frac{1}{4}$  inches square, with steel braces 1 $\frac{1}{4}$  x  $\frac{1}{4}$  inches. The T-shaped handle is of  $\frac{7}{8}$ -inch round steel, and is quickly attached to or detached from two eyelets fixed at each end. Weight, 182 pounds; handle weighs 11 $\frac{1}{2}$  pounds.

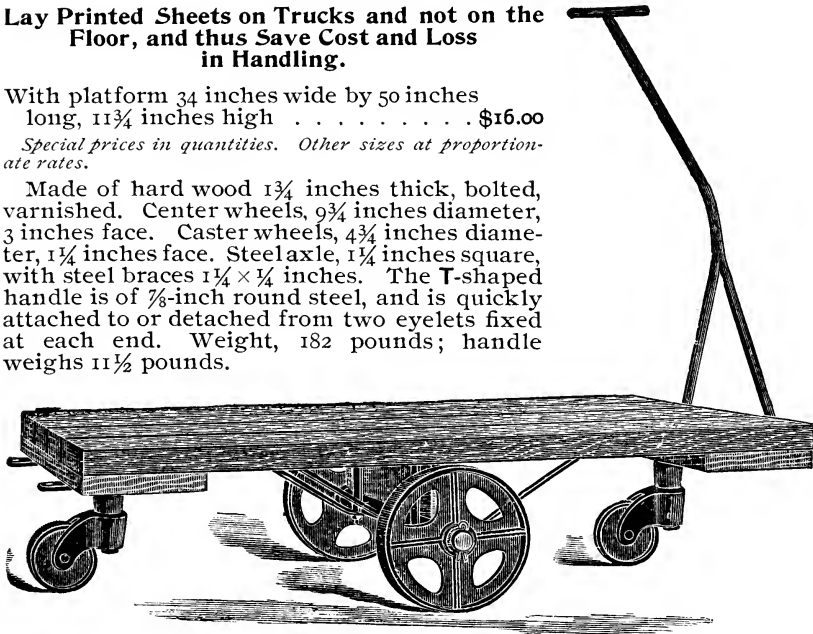

In 1896 we sold 120 of these trucks on one order to Matthews-Northrup Co., Buffalo, for use in their printing department.

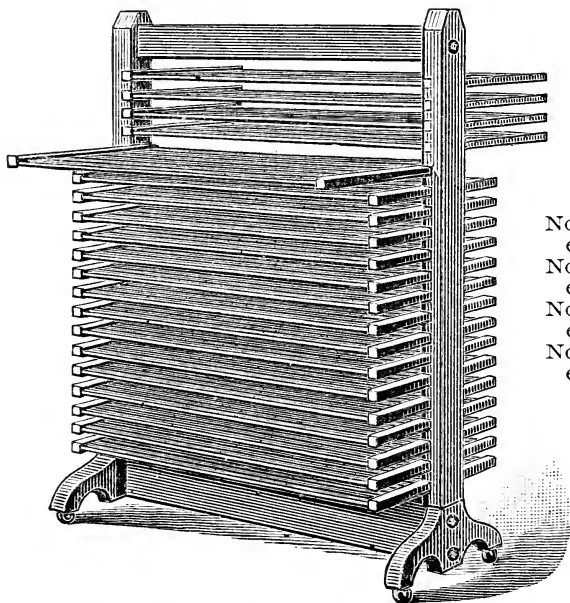

**NEW YORK  
DRYING  
RACKS.**

- No. 1, 20 shelves,  
each 24×36 in. . \$14.00
- No. 2, 30 shelves,  
each 24×36 in. . 20.00
- No. 3, 20 shelves,  
each 28×42 in. . 20.00
- No. 4, 30 shelves,  
each 28×42 in. . 28.00

The No. 1 rack (the cheapest) gives a drying area of one hundred and twenty square feet, while actually using only six square feet of your costly floor space.

No. 1. New York Drying Rack.

**CHICAGO  
DRYING RACKS.**

- | No.                        | Feet. |         |
|----------------------------|-------|---------|
| 5, 12 shelves, each 2 × 2  |       | \$14.00 |
| 6, 10 shelves, each 2 × 3  |       | 18.00   |
| 7, 10 shelves, each 2½ × 4 |       | 23.00   |

This rack is the most substantial movable drying rack made. Although it has fewer shelves than a New York, the extra space between the shelves is a distinct advantage, as on small jobs the sheets can be handled without moving the shelf on which they are placed. When not in use the shelves may be put out of the way as illustrated in cut.

The frames of both these racks are of hard wood, bolted together, and mounted on strong casters, so that they can be easily moved when loaded. The shelves of the Chicago Rack are framed all around with hard wood, while those of the New York Rack are framed on ends only.

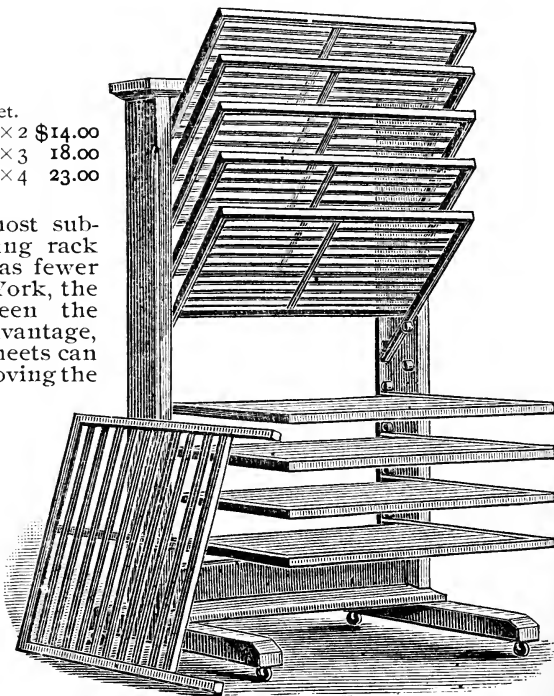

No. 6. Chicago Drying Rack.

**KÖRNER'S PATENT INTERLOCKING DRYING RACKS.**

(United States Patent, No. 392,735; Canadian Patent, No. 28,739.)

These racks are for offices which work on long runs, for color work, for lithographers. They are used on *Puck* and *Truth*, and the American Lithographic Company has over 25,000 of them in its various establishments in New York City alone.

With these racks sheets are taken direct from the fly of the press, and may be stacked ceiling-high in a perfectly straight and rigid pile, which cannot be knocked over by accident, and with no more weight on the bottom than on the top sheets. This pile is a most effective drying room, occupying only the floor space of one rack, and from the time the sheets are fed into the machine until ready for shipment they need not be handled. The interlocking device, which makes the pile straight and rigid, is shown in figure 2; each rack is firmly locked on its neighbor, but each slides with ease on the rack immediately below it. They save handling, all the time of that operation, and the consequent waste of paper through offset, smearing, finger marks and tearing. In many cases these racks save expensive slip-sheeting. They circumvent electricity by receiving the sheet direct from the fly. They insure evenness of temperature, and thereby assist in getting a perfect register on lithographic work. They save seventy-five per cent. of floor space over any other method of drying sheets, and from one to two per cent. of paper, and a vast amount of time. A further saving of time may be effected by placing the racks as they come from the fly-board on a printer's truck, made specially to take these racks (see page 841). A pile of racks can be moved quicker, safer and easier on the truck than a single armful can be moved by hand. The racks have hard wood sides with wide soft wood slats, and are very strongly put together.

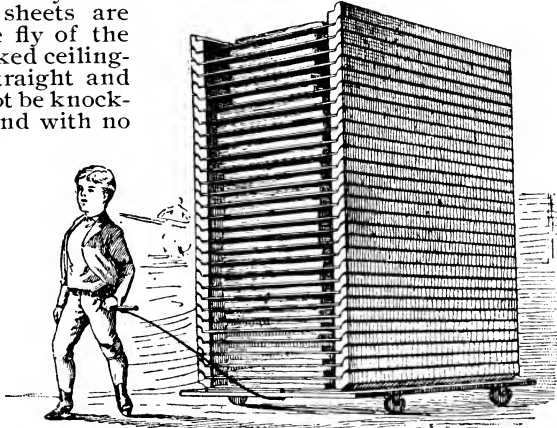

Figure 1. Patent Racks on Printer's Truck.

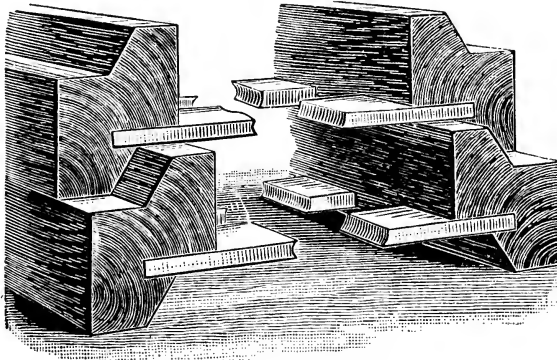

Figure 2. End View of Interlocking Device.

**NET PRICES.—Special Quotations made on Carload Lots.**

*These racks are made to order, and sizes will be varied to suit purchasers, at prices approximate to those quoted here.*

38 × 52 in. inside and under .	.65	15 × 21 in. inside and under .	\$.35
32 × 48 in. inside and under .	.60	13 × 19 in. inside and under .	.30
24 × 36 in. inside and under .	.50	11 × 17 in. inside and under .	.25
18 × 25 in. inside and under .	.40	8¾ × 13 in. inside and under .	.20

CHANDLER & PRICE GORDON PRESS.

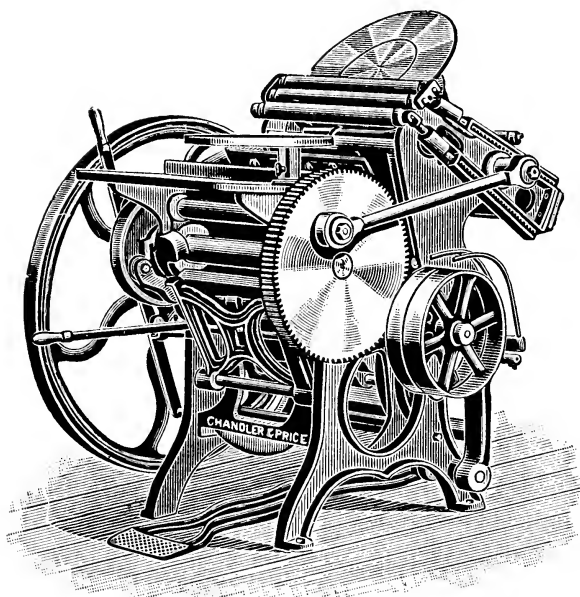

A most popular press, and over 8000 are in use. They are built to withstand both use and abuse. Side arms and shaft are made of forged steel, without seam or weld. Cam rollers are made of hardened tool steel. Impression throw-off is positive and easy to operate. The grippers are depressible, and cannot get under the rollers. Chase clamp is safe and instantaneous.

Eighth Medium,	7	× 11 inches inside chase	.....	\$150.00
Eighth Medium,	8	× 12 inches inside chase	.....	165.00
Quarto Medium,	10	× 15 inches inside chase	.....	250.00
Half Medium,	12	× 18 inches inside chase	.....	300.00
Large Half Medium,	14	× 20 inches inside chase	.....	400.00
Half Super-Royal,	14½	× 22 inches inside chase	.....	450.00
Steam Fixtures, all sizes			.....	15.00
Buckeye Fountain			.....	10.00
Chandler & Price Fountain			.....	20.00

With each press there are three chases, one brayer, two sets of roller stocks, two wrenches and one roller mould. No charge for boxing and shipping. If desired, will furnish two extra chases instead of mould.

*For prices of extra chases, see page 792.*

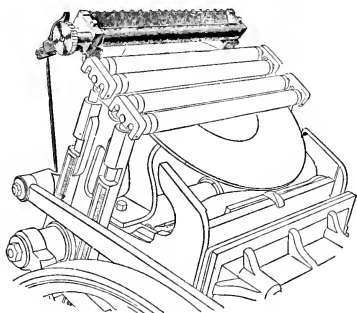

Chandler & Price Fountain.

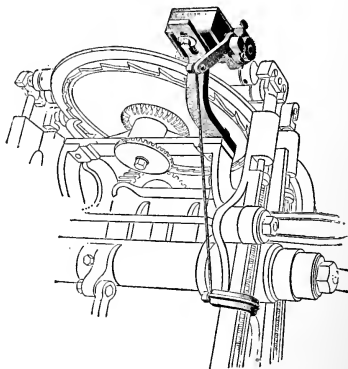

Buckeye Fountain.

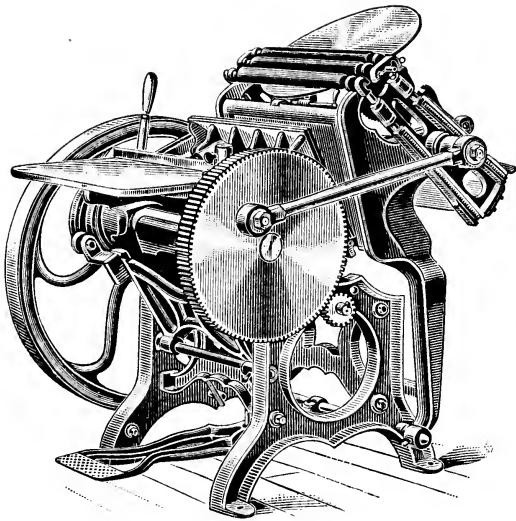

**CHALLENGE  
GORDON PRESS.**

An up-to-date press, well constructed, and with all improvements found on any Gordon press.

Sizes given are inside chase.

7 × 11 inches .	\$150.00
8 × 12 inches .	165.00
9 × 13 inches .	225.00
10 × 15 inches .	250.00
12 × 18 inches .	300.00
13 × 19 inches .	350.00
14 × 20 inches .	400.00
14½ × 22 inches .	450.00
Power fixtures, all sizes . . . .	15.00

**Challenge Pony Fountains**—For 7x11, 8x12, and 9x13 presses, \$12; for 10x15 and 12x18 presses, \$13.50; for 13x19, 14x20, and 14½x22 presses, \$15.

**Challenge Full-Length Fountains**—For 7x11, 8x12, and 9x13 presses, \$25; for 10x15 and 12x18 presses, \$27.50; for 13x19, 14x20, and 14½x22 presses, \$30.

Three chases, wrenches, roller mould, brayer and two sets of roller stocks will be furnished with each press.

**NEW STYLE  
FRANKLIN GORDON.**

The latest invention of Mr. George P. Gordon, inventor of the popular Old-Style Gordon.

**Prices.**

Sizes given are inside chase.

8 × 12 inches,	\$225.00
9 × 13 inches,	250.00
10 × 15 inches,	300.00
11 × 17 inches,	350.00
13 × 19 inches,	400.00
Ink fountains, for all sizes,	25.00
Steam fixtures, for all sizes,	15.00

One roller mould, six roller stocks, three chases, one impression wrench, one gripper wrench, and one hand-roller are included with each press.

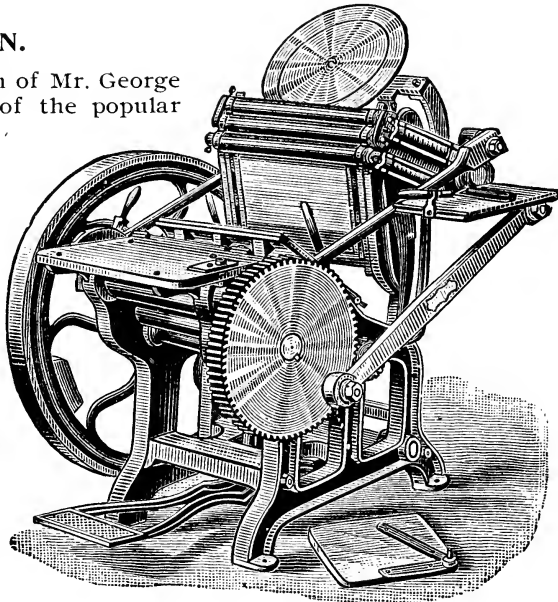

PEERLESS PRESS.

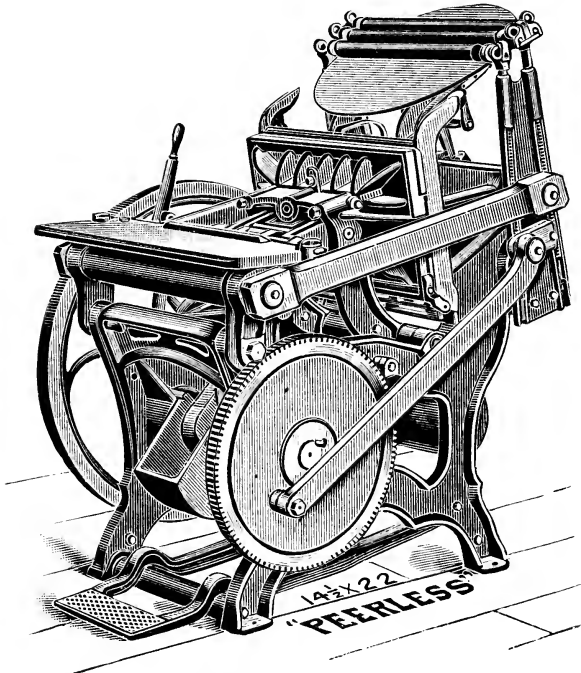

Of well-established reputation, smooth running, noiseless, easy to make-ready on, easy to feed, easy to run by treadle, with an effective throw-off, well built, exceptionally strong, and with a powerful toggle movement. The throw-off is positive and easy, and convenient to handle. The platen is sustained in the centre by the toggle, and is strongest where platens are generally weakest, enabling the Peerless to do embossing and paper-box cutting and creasing, which taxes a press very severely. It is a fast press.

Eighth Medium,	8 × 12 inches inside chase . . . . .	\$225.00
Large Eighth Medium,	9 × 13 inches inside chase . . . . .	250.00
Quarto Medium,	10 × 15 inches inside chase . . . . .	300.00
Large Quarto Medium,	11 × 17 inches inside chase . . . . .	350.00
Half Medium,	14 × 20 inches inside chase . . . . .	450.00
Half Super-Royal,	14½ × 22 inches inside chase . . . . .	50.00
Pony ink fountain, all sizes . . . . .		10.00
Hinged well ink fountain, all sizes . . . . .		25.00
Power fixtures on press, all sizes . . . . .		15.00

Three chases, six roller stocks, one roller mould, one impression wrench, one brayer, two sets roller trucks, are furnished with each press.

Extra chases cost : For 8 × 12 press, \$1.50 ; for 9 × 13, \$1.50 ; for 10 × 15, \$2.00 ; for 11 × 17, \$2.00 ; for 14 × 20, \$2.75 ; for 14½ × 22, \$3.00.



**HARRIS AUTOMATIC ENVELOPE AND CARD PRESS.**

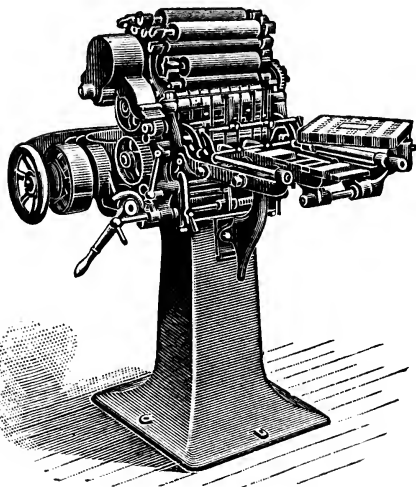

**Fastest Job Press.  
Speed from 5000 to  
12,000 per Hour.**

The Harris Automatic is a self-feeding and self-delivering press of recent introduction but well-established reputation.

It prints cards and envelopes in one or more colors in first-class style, and will supersede all other presses on work within its capacity in offices where envelopes, cards, or tags, are printed in large quantities in runs of 3000 at a time and upward. It registers closely. It has an automatic throw-off, which causes it to cease taking impressions whenever the grip-

pers fail to grasp the sheet, thus effectively preventing waste of stock as well as offsets.

The printing is done from curved stereo. or electro. plates. Making ready is convenient and easy. It is possible to make-ready and run off 5000 envelopes in forty minutes. Distribution is abundant and effective. There is an adjustable ink fountain.

The capacity is from the smallest envelope corner to plates not exceeding 11 x 13 inches.

*Prices, terms, circulars, etc., sent on application.*

**Selected from Letters Received from Users.**

*Public Printer, Washington, D. C.:* "The Government Printing Office met an extraordinary demand during the last Presidential campaign, to the extent of printing 60,000,000 (sixty million) envelopes, which would not have been met, for lack of press facilities, had we not fortunately discovered the Harris Automatic Press, which reduced the cost of envelope printing from 35 cents to 11 cents per thousand. We use another Harris press in our job room, and find it convenient for *small runs*, which work we did not anticipate doing on it at time of purchase."

*Merry & Nicholson Printing Co., St. Louis, Mo.:* "We have produced work from engravings at the rate of from 8000 to 10,000 an hour, equal in quality to the finest press work we can turn out on job presses running at from 800 to 1500 per hour. One of the most noticeable features of the press is the saving of ink, owing to its superior distribution. We made a run of 42,000 envelopes on which we used an engraving 1½ x 2½ inches, copied from a lithograph, and on starting we put a quarter pound of bronze blue ink in the fountain. When the run was finished there still remained almost half the ink in the fountain, and we used all the color the job required to make a first-class job."

*The Brooks Company, Cleveland, O.:* "We consider the Harris Automatic Press to be in every way a profitable investment. We have been using one since November, 1895, and it is all and more than you claimed for it. . . . Any intelligent feed-girl can run it, after form is made ready. We have printed 20,000 stamped envelopes at a speed of 7500 impressions or more per hour, spoiling but one envelope, and that because it was imperfectly made. We have printed over 800,000 candidate cards in lots of 5000 to 25,000 of a kind at one time."

*The A. H. Pugh Printing Company, Cincinnati, O.:* "It is very easy to make-ready, and the work we have been able to get out of it is simply astonishing."

*Albert Datz, Fersey City, N. J.:* "It is a big money-saver, doing the work previously done by four ordinary presses."

*James Kempster Printing Co., N. Y.:* "Capable of running over 50,000 impressions a day with little or no spoilage."

**General Selling Agents, AMERICAN TYPE FOUNDERS COMPANY.**

GALLY UNIVERSAL PRESS.

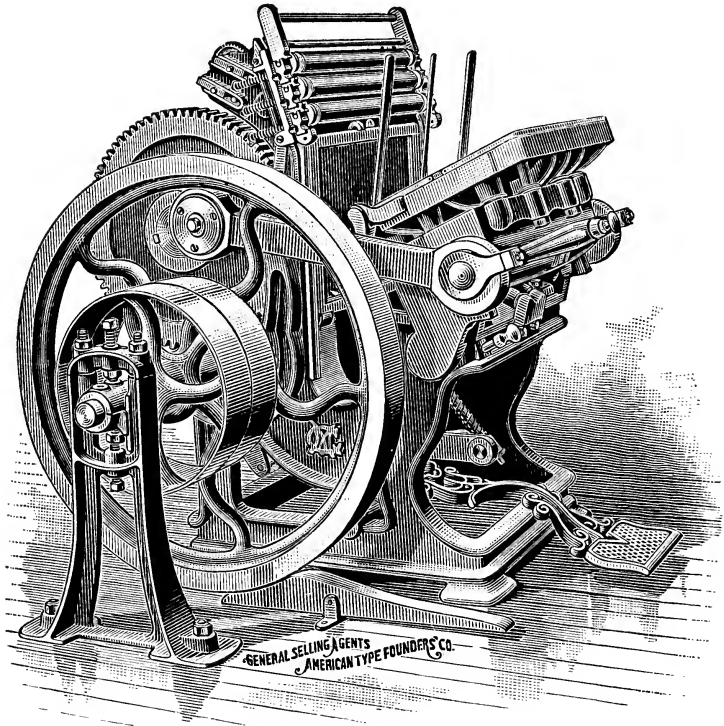

Excels all other types of platen presses because: (1) The bed and frame are cast in one piece, securing rigidity and keeping all shafts in line in spite of irregularities in floor or foundation. (2) The platen moves up squarely against the type form, giving a perfectly square impression. (3) The platen has nine supports, and is extra heavy, and is the only platen capable of sustaining the powerful impression necessary to secure the best results on large forms of cuts. (4) The impression can be thrown off instantly, the throw-off being controlled by a bar directly behind the platen. (5) The impression can be changed instantly all over the platen, varying from the imperceptible to an eighth of an inch. (6) The platen opens out widely, making it easy to feed paper into it. (7) The ink fountain is as efficient as the fountains on the highest grade cylinder presses. It is the most perfect fountain for a platen press ever made. (8) The operations of ink distribution and "inking" the form are distinct, and each performed by a separate set of rollers. In addition to the fountain ductor roller, there are four ink distributors (two of composition, two of iron) which supply two inking cylinders from which the three form rollers receive a fresh, distributed supply of ink at each impression. On all other types of presses the form rollers have to distribute the crude ink as it leaves the fountain. (9) The form rollers can be held against the inking cylinders for distribution, while getting up color, and need not touch the type form. (10) The ink fountain can be divided by partitions for printing two or more colors at one time. (11) The weight and strength are greater than in any other platen press, as it is designed to do work that cannot be safely attempted on any other type of press.

## EVERYTHING FOR THE PRINTER

The Gally Universal is designed for use by the best class of printers. In the hands of competent pressmen the press is the most durable, and will do first-class work in perfect register longer than any other press. We can refer purchasers to presses which have been in constant use for twenty years, doing perfect work to-day, and bidding fair to give the best results for years to come.

The recent application of continuous-motion impression cranks and a new patented platen control have increased the speed on all sizes. Speed requirements vary with the kind of work. These presses will run smoothly at the following maximum speeds: 10×15-inch size, 2600 per hour; 13×19 inch, 1800 per hour; 14×22 inch, 1700 per hour.

The Gally Universal Press is made in three styles, which are described hereunder.

List prices of presses for letter-press printing, complete, with ink fountain, power fixtures, combination belt-shifter and brake, f.o.b. factory:

	Style One.	Style Two.	Style Three.
Quarto Medium, 10×15 inches inside chase . . . . .	\$350.00	. . . . .	\$450.00
Half Medium, 13×19 inches inside chase . . . . .	450.00	\$500.00	600.00
Half Super-Royal, 14×22 inches inside chase . . . . .	515.00	575.00	650.00

The following small parts are included with each press: Three chases, one roller mould (for which two chases will be substituted, if preferred), six form roller stocks, four distributor roller stocks, two ductor roller stocks, twelve roller wheels (six large, six small), two iron lateral distributors, two feed tables, one small and one large wrench, one socket wrench, one chase latch wrench, and treadle fixtures.

If treadle fixtures are not required, two chases will be sent in lieu of them.

Power fixtures include fixtures on the press only.

\* See page 858 for price list of extras.

Boxing for export: Quarto Medium, \$7.00; Half Medium, \$10.00; Half Super-Royal, \$15.00, net.

### DESCRIPTION OF THE THREE STYLES.

**Style One.**—This is the style described above.

**Style Two.**—Differs from Style One in having a double impression latch and a steel segment in the gear at the point that takes the strain of the impression.

**Style Three.**—This style is recommended to those who want the best press procurable for executing the finest class of cut, solid block and color printing, cold embossing and stamping. This style is also made in combinations and for special work, as described hereafter.

The style No. 3 Universal Press differs from Style No. 1 in the following particulars:

The driving shaft is extended to carry an extra outside floor support. The pulleys are intended to carry a 2½-inch belt on Quarto Medium and a 3¼-inch belt on larger sizes. The fly-wheel on Quarto Medium weighs two hundred pounds, and on the Half Medium and Half Super-Royal three hundred pounds each. The large gear-wheel has a section of best quality of steel welded into its periphery, in which are formed the impression teeth, *i. e.*, those teeth which are in engagement with the driving pinion and transmit the momentum of the fly-wheel to the cranks during the time of the "nip." The main shaft is of steel, with solid reamed bearing through the bed. The crank-pins are crucible steel, hardened and finely finished. The connecting rods are of forged machinery steel, very heavy, and bushed with phosphor-bronze where bearing on crank-pins. The bridge and platen are solid to each other—no pressure whatever being sustained by screws. Has double impression latch.

### DESCRIPTION AND PRICES OF COMBINATIONS OF STYLE THREE FOR SPECIAL WORK.

**COMBINATION B.**—For letter-press printing and (in addition to all work that can be done on regular Style Three press, listed above) book-cover inlaying, and cutting and creasing. This combination is fitted with a movable ½-inch steel platen plate and a movable ½-inch brass platen plate, the latter for use in cutting and creasing.

Quarto Medium, 10×15 inches inside chase, complete . . . . .	\$450.00
Half Medium, 13×19 inches inside chase, complete . . . . .	626.00
Half Super-Royal, 14×22 inches inside chase, complete . . . . .	676.00

*Description and prices of other combinations on following pages (858, 859, 860).*

GALLY UNIVERSAL PRESS—Continued.

Descriptions and Prices of Special Combinations of Style Three.

**COMBINATION C.**—For letter-press printing, hot embossing and printing on wood not exceeding one inch in thickness (in addition to all work that can be done on Combination B). This combination is fitted with a steam blank ( $\frac{7}{8}$ -inch thick) with pipe connections, a movable  $\frac{1}{8}$ -inch steel die plate on steam blank, a movable  $\frac{1}{8}$ -inch steel platen plate, a movable  $\frac{1}{8}$ -inch brass platen plate, a cast-iron platen blank,  $\frac{3}{8}$ -inch thick, with tympan clamps attached, and a cast-iron platen plate  $\frac{1}{2}$ -inch thick.

In ordering Combination C, it is necessary to state the average thickness of embossing dies. It is recommended that dies should not be more than  $\frac{1}{4}$ -inch thick.

- \* Half Medium, 13 × 19 inches inside chase, complete . . . . . \$722.00
- \* Half Super-Royal, 14 × 22 inches inside chase, complete . . . . . 784.00

**COMBINATION D.**—For letter-press printing, printing on wood (not exceeding one inch in thickness) and cold embossing. This combination is fitted with a  $\frac{7}{8}$ -inch movable platen blank and a  $\frac{1}{8}$ -inch movable steel platen plate. Cutting and creasing can be done on this combination by adding a  $\frac{1}{8}$ -inch brass platen plate, list prices \$10.00 to \$13.00 each.

- \* Quarto Medium, 10 × 15 inches inside chase, complete . . . . . \$474.00
- \* Half Medium, 13 × 19 inches inside chase, complete . . . . . 629.00
- \* Half Super-Royal, 14 × 22 inches inside chase, complete . . . . . 679.00

\*IMPORTANT NOTICE.

The specifications given for preceding combinations may be varied to accommodate the requirements of purchasers. In ordering variations from above specifications be careful to state exact thickness of plates and blanks required, and fully describe the work to be done on the press ordered. Special combinations for other purposes made to order at prices proportionate to those charged for above combinations.

Price List of Attachments for Gally Universal Press.

	10 X 15 Press.	13 X 19 Press.	14 X 22 Press.
Ink fountain . . . . .	\$20.00	\$25.00	\$25.00
Fountain partitions, each . . . . .	4.00	4.00	4.00
Power fixtures on press only . . . . .	10.00	10.00	10.00
Overhead fixtures, complete . . . . .	25.00	30.00	30.00
Cast-iron chases . . . . .	2.00	2.25	2.75
Wrought-iron chases . . . . .	5.50	6.50	7.25
Roller stocks . . . . .	.60	.65	.75

Gally Universal System of Ink Distribution.

The superiority of the Gally Universal system of ink distribution over disc distribution is demonstrated by this sectional diagram. *C* is the main distributing cylinder, and *S* is the secondary distributing cylinder. The composition distributors *e* and *e'* are revolving between the cylinders and two iron distributors *v* and *v'*, both of which have a lateral motion. *H* is a composition ductor roller, supplying ink from the fountain *F* to the distributing cylinder. All these are revolving constantly both when the form rollers 1, 2, 3 are on and off the form. Distribution never ceases. On disc presses, distribution is done by the form rollers and intermittently. For work requiring little ink the number of distributors in use may be reduced.

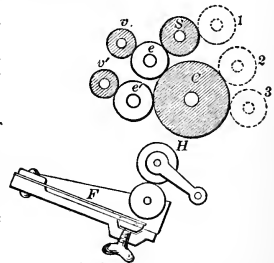

End view of system of distribution.

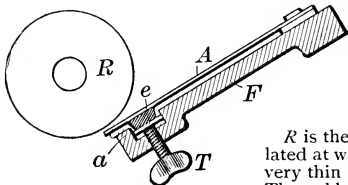

End view of Gally Universal Ink Fountain.

Gally Universal Ink Fountain.

*R* is the fountain cylinder, moved by a ratchet lever and regulated at will. *A* is a steel blade, *e* is rubber packing, and *a* is a very thin strip of steel against which the screws (*T*) are set. The rubber (*e*) furnishes an elasticity which prevents the blade from binding, while giving a perfect cut-off. There is a tendency to bind in all fountains in which the regulating screws press directly against the knife.

GALLY UNIVERSAL EMBOSSEING PRESS.

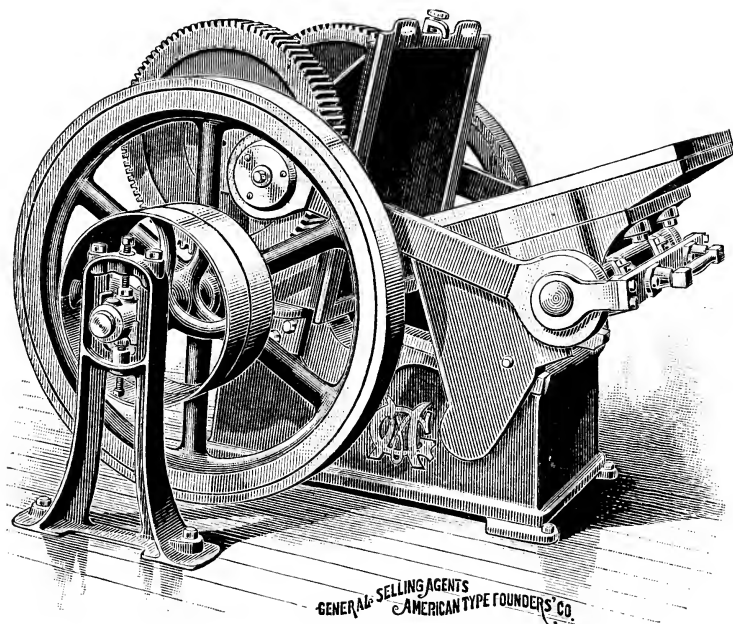

These are the largest embossing presses made, and combine strength, power, speed and facility for handling work easily in a degree unequalled by any other press. They are designed for extra heavy hot or cold process embossing, and book-cover stamping ("smashing"). Full particulars with detail of construction are given in a special catalogue, the cover of which is an exquisite example of the embossing art as well as a severe test of the capacity of the press.

**Prices of Press Only.**

No. 1. 21¼ × 22-inch bed-plate . . . . .	\$800.00
No. 2. 24 × 26-inch bed-plate . . . . .	900.00

**Prices of Extra Attachments.**

Steam blank, complete, with pipe connections, for No. 1 embosser, with steel die plate . . . . .	\$105.00
Steam blank, complete, with pipe connections, for No. 2 embosser, with steel die plate . . . . .	118.00
Steel platen plate for No. 1 embosser . . . . .	19.50
Steel platen plate for No. 2 embosser . . . . .	26.00
Cast-iron platen blank for No. 1 embosser . . . . .	19.50
Cast-iron platen blank for No. 2 embosser . . . . .	26.00

Each press is complete with power fixtures on press.  
 Each press is furnished with three chases (or one cast-iron bed blank in lieu of chases, at option of purchaser), two feed tables, one wrench, one belt-shifter, and one brake.  
 Gross weights, boxed, of embossing presses are: No. 1, 3400 pounds; No. 2, 4300 pounds.  
 Boxing for export: No. 1, \$10.00; No. 2, \$15.00, net.  
 Prices are f. o. b. factory.

**GALLY UNIVERSAL PAPER BOX CUTTING AND CREASING PRESS.**

*See "Paper Box Making" at foot of this page.*

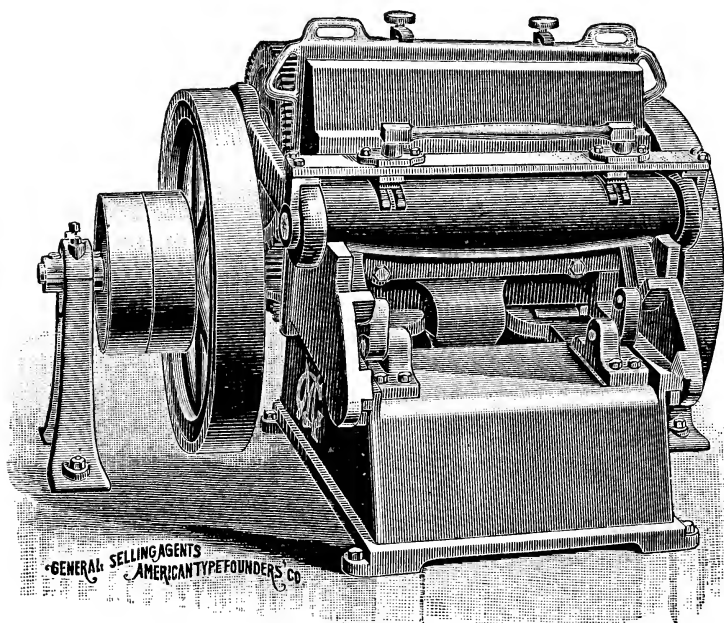

The most satisfactory presses for cutting and creasing paper boxes. Immensely strong, easy to operate, with speed limited only by capacity of feeder. They will not stall on the heaviest impression. They are built on the same general lines as the Gally Universal Embossing Presses, and have extra steel-gibbed locks on under edge of the platen to prevent deflection of the platen under unequal strain. The platen, which has a throw-off, is set to height of type unless otherwise ordered. Both sizes are double geared.

**Prices, with Brass Platen Plate and Power Fixtures on Press.**

No. 1.	20 × 30 inches inside chase	.....	\$700.00
No. 2.	23¼ × 31 inches inside chase	.....	900.00

Prices are f. o. b. factory.

Each press is furnished with a ⅛-inch brass platen plate, three chases, two feed tables, one wrench, one belt-shifter and one brake.

Boxing for export: No. 1, \$15.00; No. 2, \$20.00, net.

**FOLDING PAPER BOX MAKING.**

The process of making folding paper boxes is simple. The stock used is manilla board, made specially for the purpose. A cutting and creasing press is the same as an ordinary printing press, except that it is larger, has to be stronger, and does not require an inking apparatus. The shape of a box having been decided on, a form is set up with steel cutting and brass creasing rules—the former to cut out waste margins and to make slits, and the latter to crease or score the lines on which the stock in the box must bend when set up for use. It is usual to cut and crease as many boxes at one time as can be cut out from a full-sized sheet. The box leaves the press flat; it is then folded once and glued on one edge, and delivered flat. Any printing required is done before cutting and creasing. Any good compositor will understand the process after reading above explanation and examining a folded paper box. The glueing is done by a machine of moderate cost.

**THE GOLDING JOBBER.**

This press can be bought with or without a number of attachments, such as an automatic brayer fountain, a duplex distributor (which is placed below the bed of the press and furnishes a fresh supply of ink to the form rollers after they have passed downward over the form), a chromatic attachment, and a counter for registering the number of actual impressions, the prices for which are given separately below.

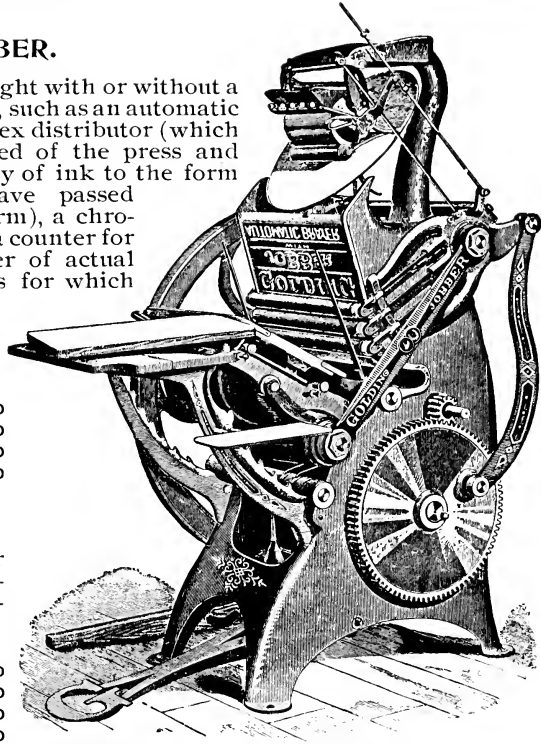

**Price of Press Only.**

Inside of Chase.

No. 6, 8×12 in.	\$200.00
No. 7, 10×15 in.	275.00
No. 8, 12×18 in.	350.00
No. 9, 15×21 in.	450.00

**Prices of Complete Press**

With automatic brayer fountain, duplex distributor and power fixtures.

Inside of Chase.

No. 6, 8×12 in.	\$245.00
No. 7, 10×15 in.	335.00
No. 8, 12×18 in.	420.00
No. 9, 15×21 in.	520.00

Shows style of Nos. 6, 7 and 8 Golding Jobbers.

The prices of all Golding Jobbers for letter-press printing include three machine rollers complete, extra set of roller cores, extra set of roller wheels, two chases, ink plate, hand roller, wrench, treadle and brake.

**Prices of Attachments and Extras.**

When not ordered complete, any of the attachments or extras wanted will be charged at the following prices:

	No. 6.	No. 7.	No. 8.	No. 9.
Fountain and automatic brayer . . . . .	\$25.00	\$35.00	\$40.00	\$50.00
Duplex distributor . . . . .	12.00	16.00	20.00	24.00
Chases . . . . .	1.25	1.50	1.75	2.25
Counter made to attach to press (counts to 10,000) . . . . .	10.00	10.00	10.00	10.00
Pearl ink fountain . . . . .	9.00	9.00	9.00	. . .
Power fixtures . . . . .	12.00	14.00	14.00	15.00
Boxing . . . . .	4.00	5.00	6.00	8.00

**GOLDING ART JOBBER.**

This press is built on the same general lines as the Nos. 6, 7 and 8, illustrated above, but is heavier and stronger; has gear-wheel inside the frame; has impression adjustment at back of bed instead of at back of platen; has four form rollers and a duplex distributor (the latter placed immediately under bed, so that ink on rollers is re-distributed before the rollers return over the type form); throw-off by means of an eccentric shaft instead of by wedges; and the automatic brayer fountain covers the full length of the disc instead of half of it. This press is also supplied with the half-length automatic brayer fountain, if desired.

No. 18 Golding Art Jobber, 12×18 ins., complete with power fixtures	\$500
No. 18 Golding Art Jobber, 12×18 ins., with half-length automatic brayer fountain, and power fixtures . . . . .	470

CHROMATIC ATTACHMENT for No. 7 Jobber, including full-length fountain, \$65.00 additional to price of complete press; for No. 18 Art Jobber, having full-length fountain, \$50.00 extra.

**PEARL PRESS.**

Light running presses, without side-arms, very rapid, easy to feed, and handy to make-ready on. They are practically noiseless, easy to keep in repair, and specially desirable in offices that have no power. The No. 1 has three drawers and the No. 3 two drawers in their stands.

Nos. 1, 3 and 5 have no throw-off.

- No. 1, 5×8 in.  
inside chase . \$70.00
- No. 3, 7×11 in.  
inside chase . 110.00
- No. 5, 9×14 in.  
inside chase . 165.00

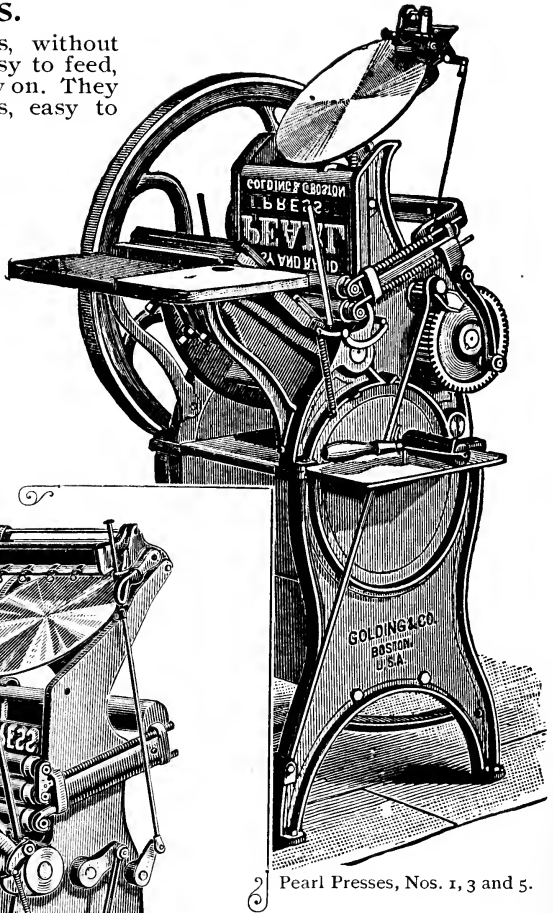

Pearl Presses, Nos. 1, 3 and 5.

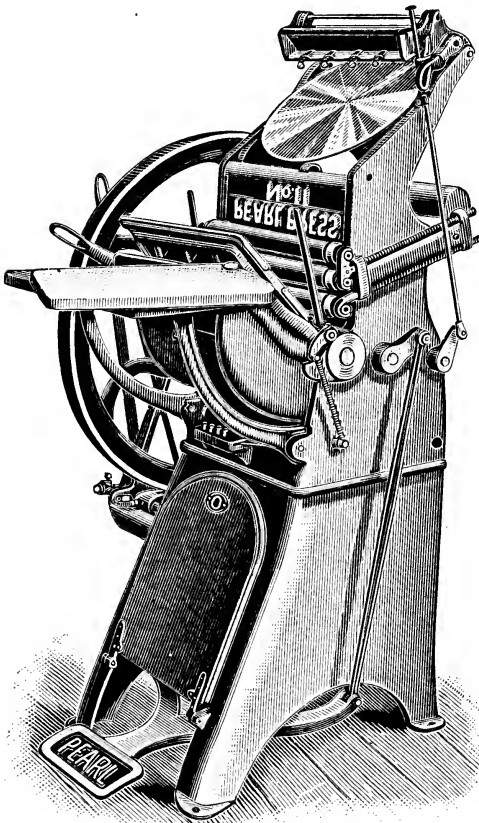

Pearl Presses, Nos. 11 and 14.

- No. 11, 7×11 inches  
inside chase . . \$135.00
- No. 14, 9×14 inches  
inside chase . . 200.00

The prices of Nos. 11 and 14 include full-length fountain and throw-off.

**Steam Fixtures.**

- For No. 1 . . . . . \$8.00
- For No. 3 . . . . . 9.00
- For Nos. 5 and 11 . . . 12.00
- For No. 14 . . . . . 14.00

**Pearl Ink Fountains.**

Nos. 1, 3 and 5, each . \$9.00



**THE ADAMS HAND CYLINDER PRESS.**

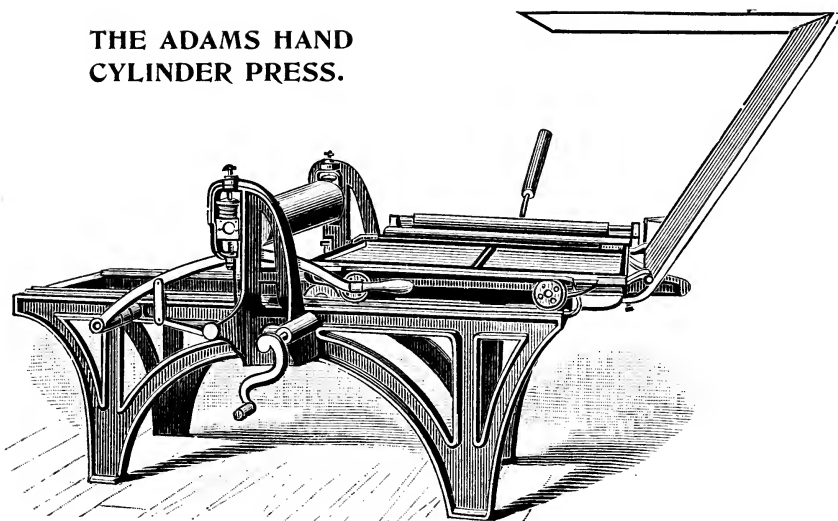

A substitute for the Washington Press. All "pulling" of the lever is dispensed with. It is simply a question of rolling the bed under the cylinder and back again, and the sheet is printed. From one-third to one-half more sheets can be printed in the same time that can be done on the Washington, and with little expenditure of strength.

Each press complete with felt blanket, inking apparatus, roller frame, one cast roller, and one extra roller core.

- 6-Column Folio—bed, 24×35 inches; weight, 975 lbs. . . . \$225.00
- 7-Column Folio—bed, 27¼×40½ inches; weight, 1100 lbs. . . 240.00
- 8-Column Folio or 5-Column Quarto—bed, 28¾×43 inches;  
weight, 1280 lbs. . . . . 260.00

Speed, 300 to 400 per hour.

**PILOT HAND LEVER PRESS.**

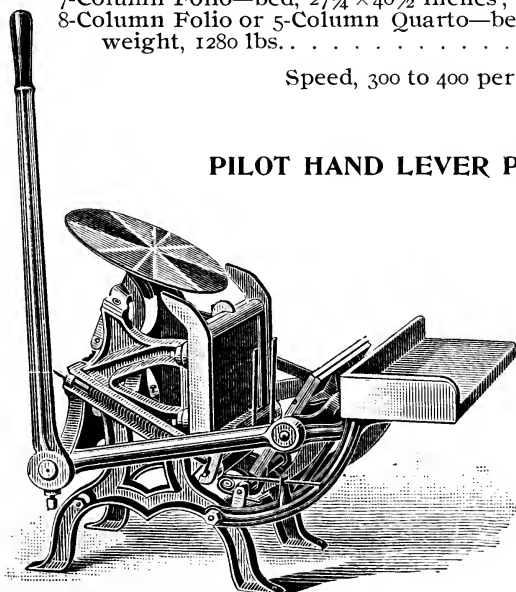

Pilot Press

- 6½×10 inches in-  
side chase . . . \$35.00
- Ink Fountain . . . 10.00

One chase, one set of covered rollers, and one wrench supplied with each press.

**OFFICIAL  
HAND LEVER  
PRESSES.**

- No. 3, 5 × 7½ in. . \$25.00
- No. 4, 6 × 9 in. . . 35.00
- No. 6, 8¼ × 12½ in. . 60.00

One chase, one set of covered rollers, and one wrench supplied with each press.

WASHINGTON HAND PRESS.

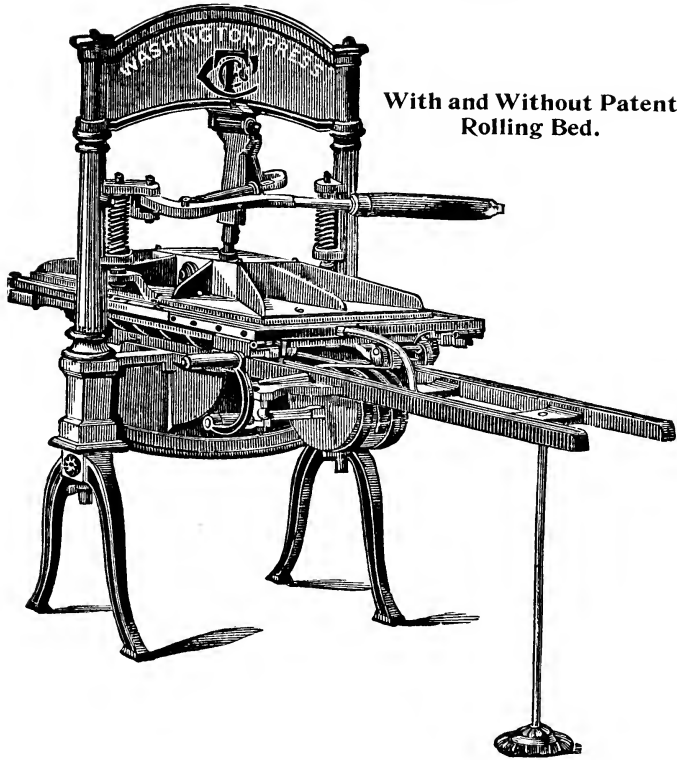

Platen.	Bed.	Price.
14 × 18 inches . . .	17 × 21 inches . . . . .	\$150.00
16 × 21 inches . . .	20 × 25 inches . . . . .	175.00
20 × 25 inches . . .	24 × 29 inches . . . . .	200.00
23 × 31 inches . . .	25¾ × 34¾ inches, for 6-col. folio . . . . .	200.00
23 × 35 inches . . .	26½ × 39 inches, for 7 col. folio . . . . .	225.00
25 × 39 inches . . .	28½ × 42 inches, for 8-col. folio or 5-col. quarto . . . . .	250.00
27 × 43 inches . . .	31½ × 47½ inches, for 9-col. folio . . . . .	275.00

**With Patent Rolling Bed.**

The Patent Rolling Bed runs on rollers instead of sliding, and thus much exertion is spared the pressman, and the work is done quicker.

Platen.	Bed.	Price.
23 × 35 inches . . .	26½ × 39½ inches, for 7-col. folio . . . . .	\$250.00
25 × 39 inches . . .	28½ × 43½ inches, for 8 col. folio or 5-col. quarto . . . . .	275.00
27 × 43 inches . . .	31½ × 47½ inches, for 9-col. folio . . . . .	300.00
29 × 43 inches . . .	33 × 48 inches, for 6-col. quarto . . . . .	325.00

Above prices include two pairs of points, one wrench, one sheep'sfoot, pair of bearers, and one extra frisket.

**As a rule, we can supply second-hand Washington Hand Presses of all sizes on demand.**

IMPROVED COUNTRY PROUTY.

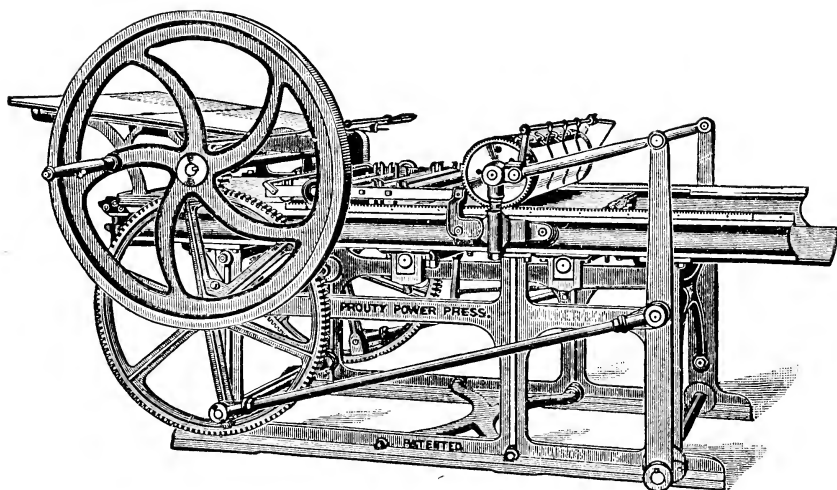

Square sides, patent 'square drop-bed and throw-off. Self-inking. The cylinder rolls over the type form after taking the sheet from the feed-board. The rollers follow the cylinder over the type form.

	Size, inside bearers, in.	Weight, pounds.	Price.
No. 1, 7-column folio . . . . .	27 × 37	3600	\$600.00
No. 2, 8-column folio . . . . .	27½ × 43½	4000	700.00
No. 3, 6-column quarto . . . . .	32½ × 46½	4600	800.00

The above prices include well fountain, rubber blanket, set of cast rollers, set of extra cores, and patent throw-off and impression lock. All boxed and on board cars. Steam fixtures, \$15.00 extra.

ARMY PRESS.

This is the lowest priced press on which a newspaper of small circulation can be printed. The cylinder is stationary, but adjustable for impression by regulating screws at each end. The bed and form pass under the cylinder, and an impression is taken at each forward and backward movement.

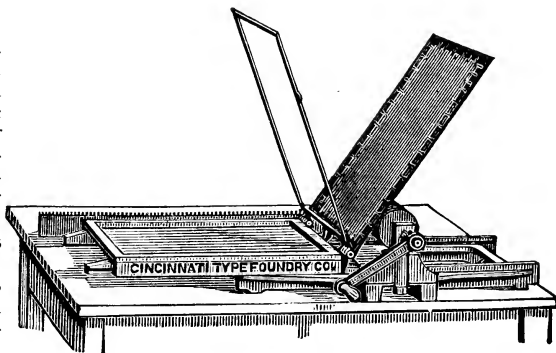

To print one page, 6-column folio, 14 × 20 inches . . . . .	\$ 60.00
To print one page, 7-column folio, 16½ × 22¾ inches . . . . .	85.00
To print one page, 8-column folio, 19¼ × 25½ inches . . . . .	120.00
To print two pages, 5-column folio, 19½ × 26 inches . . . . .	125.00

Two chases, six patent quoins, roller frame and cast roller, oiler and wrench, go with each press.

**IDEAL HAND CYLINDER PRESS.**

The type form on this press is stationary. The cylinder is moved over the tympan by link belts running over sprocket wheels at each end of the press, and it prints a sheet at each forward or backward movement. The cylinder is made of steel, and is held firmly to the tracks

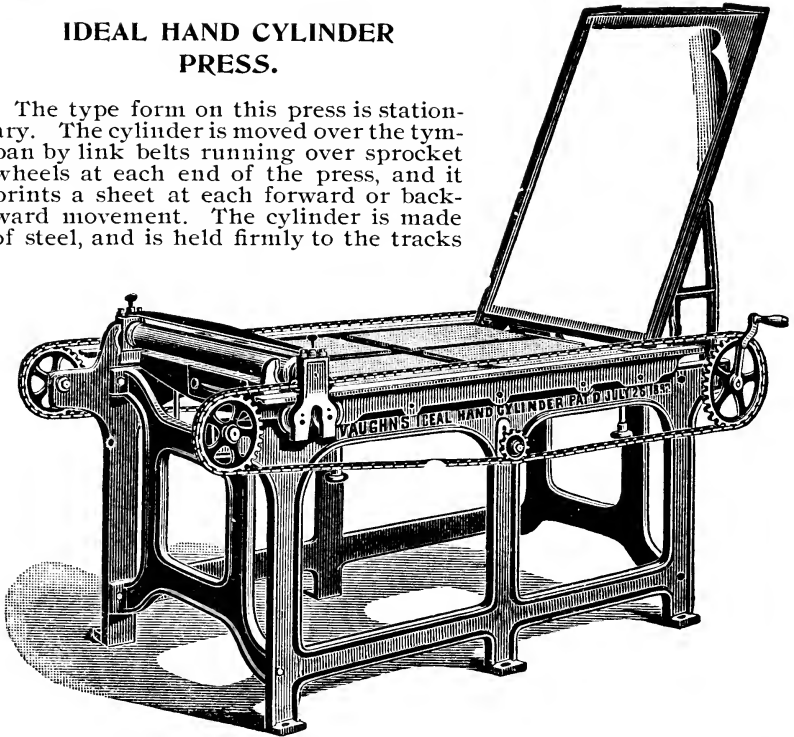

by truck-wheels which run in a groove on the under side of the tracks. The boxes which hold the cylinder at each end, and in which it revolves, are connected by a stretcher rod running above the cylinder, which prevents side friction. The impression is regulated by four screws—two on each side—which raise or depress the bearers on which the cylinder runs. An effective inking apparatus is supplied, but is extra. A number of Ideal Presses are in use, and intending purchasers may gather how satisfactory they are to the users by reading the following extracts from a great many commendatory letters received:

"My wife ran off 300 an hour on it the first day it was put up." \* \* \* "With it our inexperienced pressman has made the following speed: 750 impressions in 75 minutes; 475 in one hour; 100 in 11 minutes. We run a regular lick of 100 every 15 minutes, or 400 per hour." \* \* \* "We can run an edition in one-half the time and secure a better print than on our Washington." \* \* \* "The presswork done by the 8-column Ideal is good. . . . The press is so simple that the veriest novice can set it up, and so light running that a boy may operate it with ease." \* \* \* "It is far superior to my old Washington for speed and quality of work."

- No. 1. 8-col. folio or 5-col. quarto, size of bed, 28½ × 43 inches . \$200.00  
 No. 2. 9-col. folio or 6-col. quarto, size of bed, 33½ × 48¼ inches . 225.00  
 No. 1. Floor space, 31x55 . . . . . Weight, 700 lbs. . . . . Shipping weight, 975 lbs.  
 No. 2. Floor space, 35x60 . . . . . Weight, 800 lbs. . . . . Shipping weight, 1100 lbs.  
 Frisket for No. 1 extra, \$6.00; for No. 2, \$6.50.

**IDEAL INKING APPARATUS.**

Attaches to the side of press; has a drop-table, which allows the roller to pass from distributor to the form without lifting, and without touching furniture or chase; has automatic vibrator.

- No. 1. For 8-column folio or 5-column quarto . . . . . \$30.00  
 No. 2. For 9-column folio or 6-column quarto . . . . . 32.00

CAMPBELL COUNTRY HAND CYLINDER PRESS.

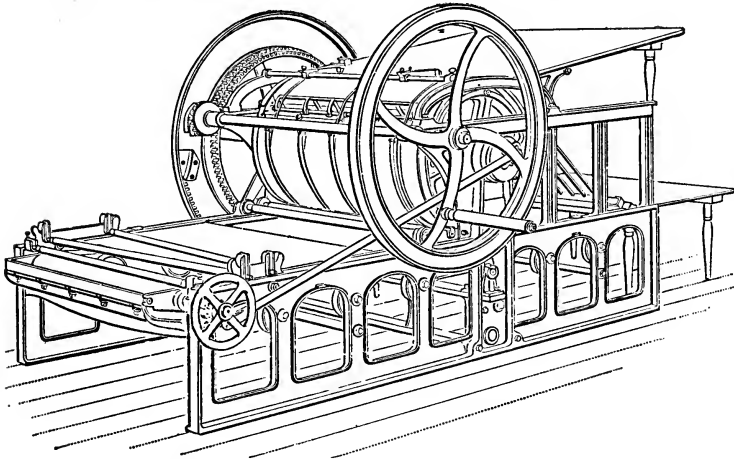

- No. 2. Bed, 33×48 inches. Form, 28×44 inches. Standard size for 9-column folio and 6-column quarto . . . . . \$800.00
- No. 3. Bed, 30×43 inches, Form, 25×39 inches. Standard size for 8-column folio and 5-column quarto . . . . . 700.00

A rubber blanket, one set composition rollers, extra set stocks, tapes, wrenches, boxing and shipping, are furnished with these presses.

Tight and loose pulleys and belt shifter for power, \$15.00 extra.

The Campbell Country Hand Cylinder forms a class by itself, and occupies, without a satisfactory rival, the entire field between the Washington hand press and the power cylinder. Thousands are in use, and it has proved a stepping-stone to fortune for a great number of publishers during the past thirty years. It is constructed on the same successful mechanical principles as are used in building the more expensive power cylinder presses, and power fixtures may be added at a small cost. The wear of type on this press is much less than on that class of presses which are constructed on the crude principles of a proof press.

**Testimonials Selected from Hundreds Equally Favorable.**

*J. H. Wilcox, Portsmouth, Va.:* "You are mistaken as to my having purchased a Campbell Hand Cylinder Country Press in 1890. I bought one in 1886, and I take great pleasure in saying that it has proved in every way most satisfactory. One small man can turn it continually for hours with ease. It does not get out of order except through negligence, and it is very simple in its operation. This press, I believe, is about sixteen years old, if not older, and it will probably last another sixteen years, if not longer."

*Theo. P. Wilson, Winchester, Mass.:* "The Campbell Hand Cylinder Country Press purchased from you in August, 1889, has given the utmost satisfaction during its over two years of constant service. I have not spent a cent for repairs, and consider it as good as when first set up. The press is now run by water-power, and can print 900 papers per hour. The *Star* I consider one of the cleanest printed papers in this section."

*Paragraph Publishing Co., Mamaroneck, N. Y.:* "We take great pleasure in saying that the Campbell Hand Cylinder Press purchased of you in September, 1890, has proved in every respect a first-class machine. Although intended to be run by hand, we have been running our press by power for the last three months at an average speed of 840 to 900 per hour. As the press has no springs, we consider this a performance with which we are pleased, and of which you have reason to be proud."

*T. H. Harter, Middleburgh, Pa.:* "I have been using a Campbell Press for four years, and take pleasure in recommending it to the trade. For simplicity, durability and ease on type it cannot be excelled. My issue of 1600 (6-column quarto) is turned off in two-and-a-half-hours, including all stops, and the press hasn't been out of order since I had it, with the exception of the fly-spring breaking. I would not trade it with any press on the market for a country office."

*Irwin H. Bardman, Schuonksville, Pa.:* "The Campbell Hand Cylinder Country Press I purchased June 4, 1888, has been in use ever since, and has not cost a penny for repairs, and is always ready for work, and is one of my best friends in the office. I do not believe that the press can be excelled for simplicity, durability and convenience. It runs very easy by hand, but I drive it with a gasoline engine."

COTTRELL TRIUMPH COUNTRY PRESS

With Patent  
Air Springs.

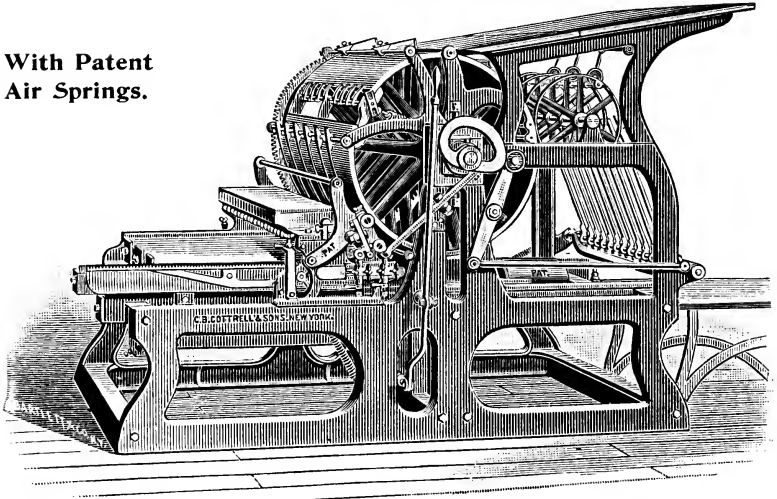

Adapted for printing newspapers, pamphlets, posters, circulars, and all classes of commercial printing. Conforms in construction, design, durability and finish to the high reputation of the manufacturers.

The press is supplied with patent air springs, the resistance of which is increased or decreased according to the speed of the press. It is well-known that the faster the speed the greater strength of spring is required. The patent air spring covers these requirements. If the press is running at five hundred per hour, the spring can be easily regulated for that speed; and if running at fifteen hundred per hour, the proportionate increase of spring can be obtained, and so up to the highest speed of which this press is capable. The air spring is provided with an automatic throw-off that releases the pressure when the press is stopped, and the pressman can move the bed to and fro without compressing the spring. When the press is started, the spring is applied automatically.

The patent hinged roller-frame permits of the rollers being instantly uncovered for removal or other purposes without unscrewing the sockets. The rollers can be taken out and put back without changing their set. The well-fountain is used, being easily regulated and cleansed, and it is set high, giving easy access to the form. The distribution is ample—two three-inch rollers, covering the full form. The bed has four supports while under impression, thus securing a clear, even impression. The shoes, tracks and rollers are of hard steel. The gearing is accurately cut, which, together with the registering rack and segment, insures perfect register.

The Triumph Press is built with table, rack and cam distribution, or with the rack and cam distribution, as per illustration on this page.

The Triumph Press can be fitted to run by hand power, when so desired. Tapeless delivery furnished, when required, at an extra charge.

**Sizes and List Prices with Rack and Cam Distribution.**

	Size of bed inside bearers.	Size of form covered by rollers.	List Price.
No. 3 . . . . .	26 × 37 inches	22 × 33 inches	\$1000.00
No. 5 . . . . .	33 × 47 inches	28 × 44 inches	1100.00

Steam fixtures, extra, \$50.00. Tapeless delivery, extra, \$75.00. Table, rack and cam distribution, extra, \$75.00.

Price includes rubber blanket, wrenches, two sets of roller stocks, roller moulds, boxing and shipping.

**COTTRELL MONARCH TWO-ROLLER PRESS.**

**Air Springs. Tapeless Delivery. Back-Up Movement. Hinged Roller-Frame.**

**With Two Rollers  
Covering Form**

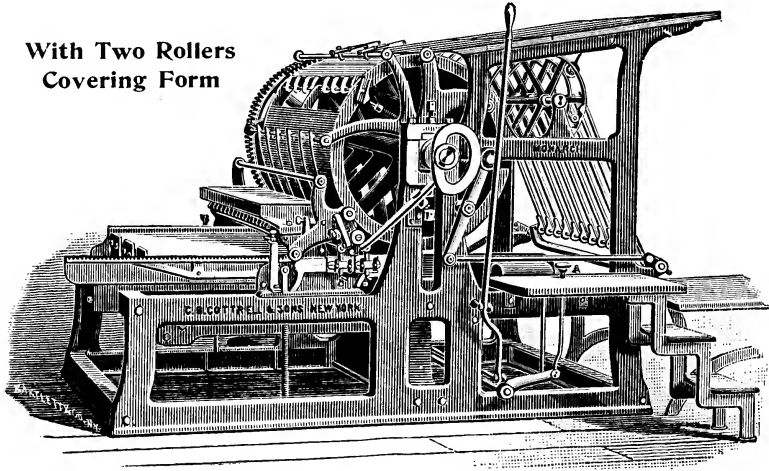

It has many advantages and improvements, including patent air-springs, patent tapeless delivery, back-up movement, hinged roller-frame, and iron steps and feeder's stand, and in its manufacture quality is placed first and cost afterward.

It is a press of excellent design, of the best materials, of high speed, but by manufacturing them in large quantities, and building but two sizes, the price is put within the reach of the printer of moderate means.

It is a fast press—1600 per hour is easily possible on the larger and 2000 on the smaller size.

It has four bearings under the bed for extreme rigidity and strength, and steel tracks and steel rollers. There is a heavy flange on the ends of the cylinder as an added element of strength.

The patent air spring forms an easy cushion for the bed in passing the centers, is under perfect control, and can be readily adjusted for the different speeds. The air spring has a new automatic throw-off, so that in turning over the centres by hand the spring is not compressed.

The patent back-up movement is a great convenience and a labor-saver.

The patent hinged roller-frame permits the form rollers to be instantly uncovered for removal or other purposes without unscrewing the sockets. The rollers can be taken out and put back without changing their set.

The well fountain is used, being easily regulated and cleaned. It is set high, giving easy access to the form.

Furnished with table and rack and cam distribution at an extra charge, or only with rack and cam distribution as illustrated.

Size of bed inside of bearers.	Size of form covered by two rollers.	List Price.
No. 3, 26 × 37 inches . . . . .	22 × 33 inches . . . . .	\$1500.00
No. 5, 33 × 47 inches . . . . .	28 × 44 inches . . . . .	1800.00

Table distribution, \$75.00 extra.

Price includes hard-packing or rubber blanket, wrenches, two sets of composition roller stocks, roller moulds, countershaft, two hangers, two four-speed cone pulleys and driving pulley, boxing and shipping.

COTTRELL PARAGON JOB AND NEWSPAPER PRESS.

With Two Rollers  
Covering a Full Form

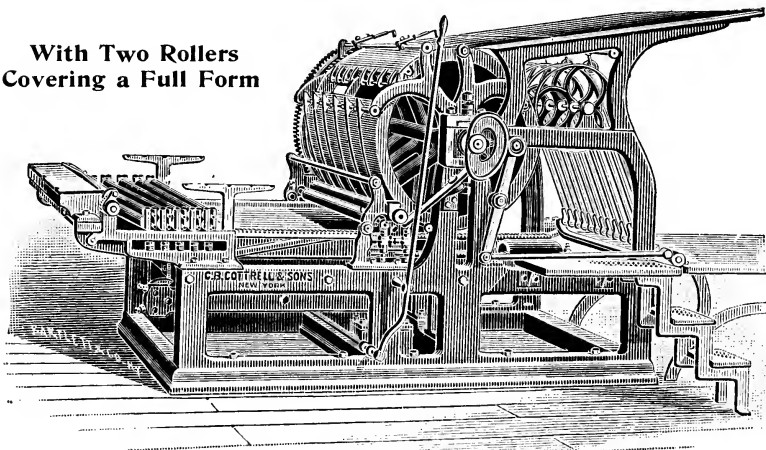

The side frames rest upon and are fastened to a substantial bed-plate, thus insuring stiffness and rigidity of construction. The side frames are changed in design, the flanges projecting inward, and are massive in appearance.

The girt is cast solid with the bed-plate, and carries a pair of substantial rollers adjustable in their box bearings. These rollers operate in connection with extra steel tracks beneath the bed, which, with the ordinary ribs, sliders and tracks, form four separate bearings directly beneath the "impression," making any spring in the bed an impossibility.

The patent air spring, as applied to the press, forms an easy cushion for the bed in passing the centers, and can be readily adjusted for the different speeds.

In connection with the air spring is an automatic throw-off, which permits of the press being turned by hand without compressing the spring. This device is entirely automatic, and does not require any attention.

These presses are supplied with the well-fountain, placed high above the bed, to admit of easy access to the form. The roller frames are hinged in such a manner as to enable the pressman to open them in an instant, leaving the form rollers free for removal. The roller bearings are made adjustable in every direction.

The sheet delivery is tapeless, and fingers of the fly are adjustable transversely to suit position of delivery wheels and nature of sheet to be delivered. The ends of the cylinder are flanged to increase its rigidity.

The Paragon Press is supplied with table, rack and cam distribution, as illustrated on this page, at an extra charge, or with rack and cam distribution.

	Size of bed inside bearers.	Size of form cov- ered by two rollers.	List Price.
No. 5 . . . . .	33×47 inches	29×43 inches	\$1900.00
No. 6 . . . . .	33×50 inches	29×46 inches	2000.00
No. 7 } Flange Frames	{ 34×52 inches	31×49 inches	2200.00
No. 8 }	{ 37×54 inches	34×51 inches	2500.00

Table distribution, \$75.00 extra.

Price includes hard-packing or rubber blanket, wrenches, two sets of composition roller stocks, roller moulds, countershaft, two hangers, two four-speed cone pulleys and driving pulley, boxing and shipping.



**OSTRANDER-SEYMOUR PONY WEB PERFECTING PRESS.**

**A Reliable  
Low-Priced  
Perfecting Press.**

This press is designed for newspapers with a circulation which cannot be handled satisfactorily on flat-bed cylinders, but which could not profitably utilize high-priced and more elaborate perfecting presses. The Pony Web can be worked economically, will do work equal to a press costing twice as much, and can be depended upon for durability, based on good materials and good workmanship.

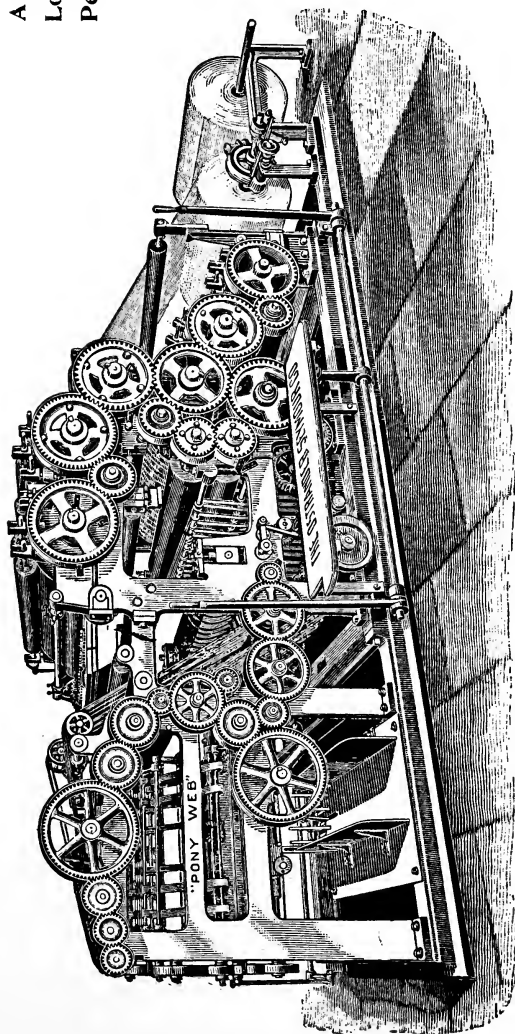

This Pony Web Press is complete with stereotyping apparatus, make-up tables and chases, and will print four-page or eight-page papers of either 6 or 7 columns, or 7 or 8-column sizes, at a speed of from 10,000 to 12,000 per hour. Prices, terms and full particulars sent on application. Can be built to order for special work at moderate additional cost.

**General Selling Agents, AMERICAN TYPE FOUNDERS COMPANY,**  
Leading Merchants in Printing Presses.

AMERICAN TYPE FOUNDERS CO.

**THE CRANSTON NEWSPAPER PRESS.**

*For description, prices, etc., see opposite page.*

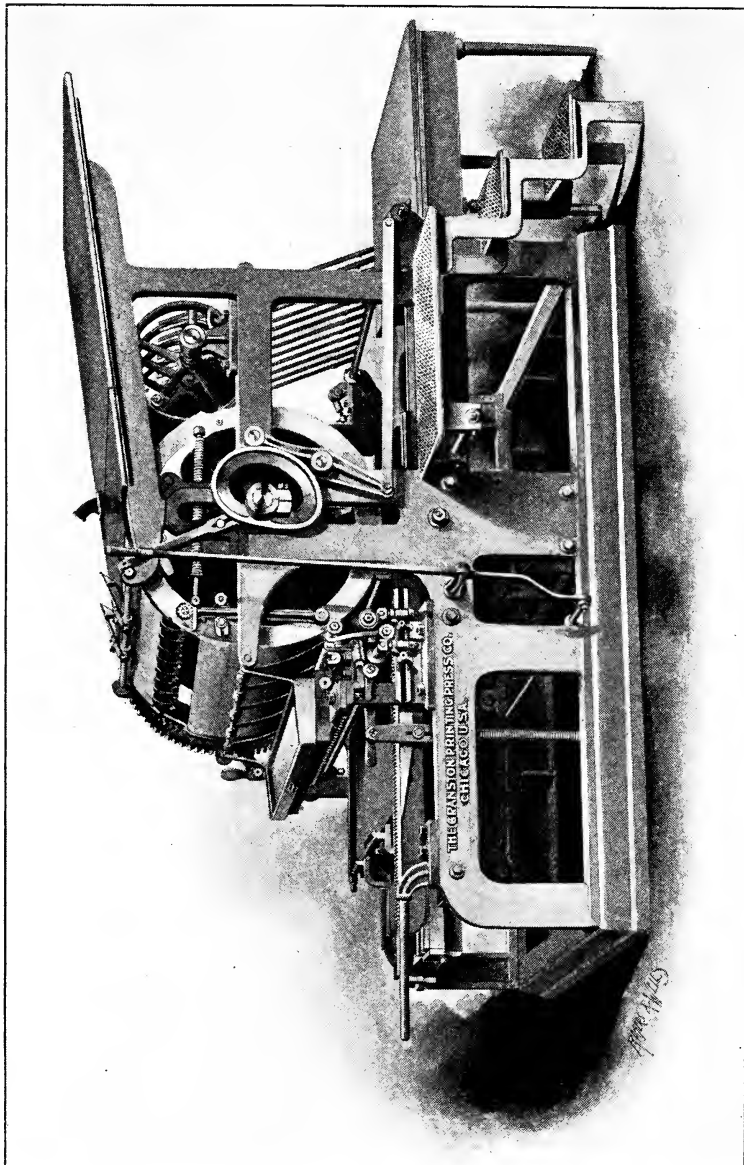

**THE CRANSTON NEWSPAPER PRESS.**

**Two-Roller, with Rack and Pinion Distribution.**

*See illustration on opposite page.*

Built of the best material; furnished at a moderate price; put to practical tests; it has proved by constant use to be an economical press to buy. The runners on both track and table are steel; the shafts, rolls, studs, shoes and wearing parts are also steel. All gears and racks are cut from the solid. The press is provided with air springs, tapeless delivery, noiseless gripper motion, continuous fly cam, adjustable feed guides. The fountain is placed high on the stands, thus giving easy access to bed of press. The form rolls are made of wrought iron pipe, and are of large size, easily placed in position and adjusted. There is a brake, a fountain cover, reel rod for blauket and tympan, and a guard for distributing rack. Distribution is controlled by cam movements.

Size.	Inside Bearers.	Matter Covered.	Length of Base.	Width of Base.	Weight Boxed.	Price.
No. 3½ . .	33×48 . .	28×44 . .	7 ft. 7½ in. . .	5 ft. 3½ in. . .	9000 .	\$1600.00

An additional charge for table distribution.

Each press is furnished with overhead fixtures complete (except when furnished with hand power only), blanket, wrenches and one set stocks, also one extra set stocks and iron steps.

**THE CRANSTON IMPROVED NEWSPAPER PRESS.**

**Two-Roller, with Rack and Pinion Distribution.**

The Improved Newspaper Press has been materially changed in construction and general appearance. All racks and gears have wide faces and are cut from the solid. The press has air springs; tapeless delivery—wheels adjustable to any size sheet; patented device for controlling motion of sliders; patent stop and reversing motion; noiseless gripper motion; continuous fly cam; feed guides that are capable of the finest adjustment; large size form rollers; long register rack and segment; deep fountain; cover for fountain; convenient arrangement for adjusting fountain roll; cylinder distribution.

Every convenient feature that the price at which it is offered will permit is put on this press, effecting a saving of time and labor for which the Cranston presses are well and favorably known.

Each press is furnished with overhead fixtures complete, blanket or hard packing, wrenches, iron steps, two complete sets stocks—one set cast with composition ready for immediate use.

Size.	Inside Bearers.	Matter Covered.	Length of Base.	Width of Base.	Weight Boxed.	Price.
No. 3½ . .	33×48 . .	28×44 . .	7 ft. 7½ in. . .	5 ft. 3½ in. . .	9500 .	\$1800.00

Table distribution extra.

**THE CRANSTON PATENT IMPROVED TWO-ROLLER PRESS.**

*For description, etc., see opposite page.*

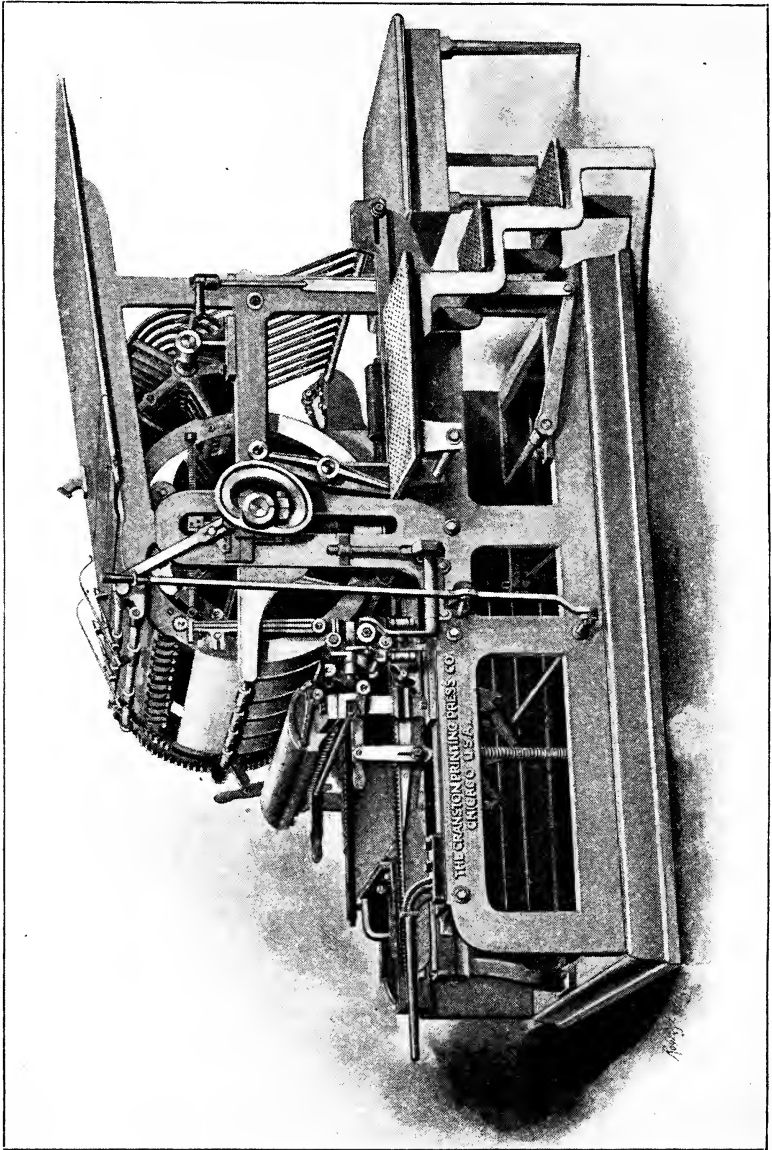

**THE CRANSTON PATENT IMPROVED TWO-ROLLER PRINTING PRESS.**

**For Fine Book, Commercial and Newspaper Printing.**

*See illustration on opposite page.*

This press is carefully made in every detail. The stock and finish are unexcelled. The tracks are wide, and provided with steel rolls and runners. The wearing parts, shafts, knuckles, shoes, studs, are of steel. The gears and racks are cut from the solid, and have wide faces. The press has air springs; patent silent slider motion, which insures uniform travel of the sliders with the table; patent stop and reversing motion; improved feed guides; patent adjustable side-guide leaf on feed table, which can be set for the greatest precision of register.

The fly is operated by a silent motion, the cam having a continuous surface.

The fountain basin is deep, and will carry a large supply of ink. It is placed high on the stands, and easy access is thus given to the bed of the press.

The Cranston combines the essential features: great strength, unyielding impression, fine distribution, exact register, with convenience in adjustments and make-ready. It is operated with light power, and cannot but give satisfaction both in quantity and quality of work produced.

Size.	Inside Bearers.	Matter Covered.	Length of Base.	Width of Base.	Weight Boxed.	Price.
*No. 0 . . .	18 × 25	13 × 21	5 ft. 4 in.	3 ft. 3¼ in.	4,500	. . . . .
*No. 1 . . .	21 × 28	16 × 24	5 ft. 8¾ in.	3 ft. 8¼ in.	5,500	. . . . .
*No. 1½ . . .	21 × 36	16 × 32	5 ft. 8¾ in.	4 ft. 4½ in.	6,500	. . . . .
*No. 1A . . .	24 × 30	19 × 26	6 ft. 2½ in.	3 ft. 10¼ in.	6,500	. . . . .
No. 2 . . .	25 × 36	22 × 32	6 ft. 5½ in.	4 ft. 6 in.	7,500	. . . . .
No. 2A . . .	25 × 38	22 × 34	6 ft. 8¾ in.	4 ft. 7¾ in.	8,500	. . . . .
No. 2½ . . .	29 × 43	24 × 39	7 ft. 4½ in.	5 ft. —	10,000	. . . . .
No. 3 . . .	32 × 46	27 × 42	7 ft. 9¾ in.	5 ft. 4¼ in.	10,500	. . . . .
No. 3½ . . .	33 × 48	27 × 44	7 ft. 9¾ in.	5 ft. 5 in.	11,000	. . . . .
No. 4 . . .	34 × 50	29 × 46	8 ft. 4 in.	5 ft. 9¾ in.	13,000	. . . . .
No. 5 . . .	36 × 52	31 × 48	8 ft. 8½ in.	5 ft. 9½ in.	13,500	. . . . .
No. 5½ . . .	38 × 54	33 × 50	9 ft. —	5 ft. 11½ in.	14,000	. . . . .

\*Commercial Series.

Each press is furnished with overhead fixtures complete, blanket and hard packing, wrenches, iron steps, and two complete sets stocks.

**THE CRANSTON IMPROVED BOOK AND NEWSPAPER PRESS.**

**Two-Roller, with Rack and Pinion Distribution.**

The Improved Book and Newspaper Press has all of the features which made the Improved Newspaper Press the best newspaper press in the market, and in addition has a separate heavy cast iron base plate which gives additional strength and solidity to the machine, and makes it possible to run it at a higher rate of speed without jar or injury to the press.

It is especially designed for fine book, newspaper and general job printing. For accuracy of register and convenience of making ready, it is unexcelled. The workmanship and wearing qualities are unsurpassed.

No. 3½, 33 × 48 inches, inside bearers; 28 × 44 inches, matter covered; length of base, 7 feet 7½ inches; width of base, 5 feet 3½ inches; weight boxed, 10,000 pounds . . . . .	\$2200.00
Table distribution, extra . . . . .	100.00

Each press is furnished with overhead fixtures complete, blanket or hard packing, wrenches, iron steps, two complete sets stocks—one set cast with composition ready for immediate use.

**THE CRANSTON-VICTOR TWO-ROLLER TWO-REVOLUTION PRESS.**

*For description, etc., see opposite page.*

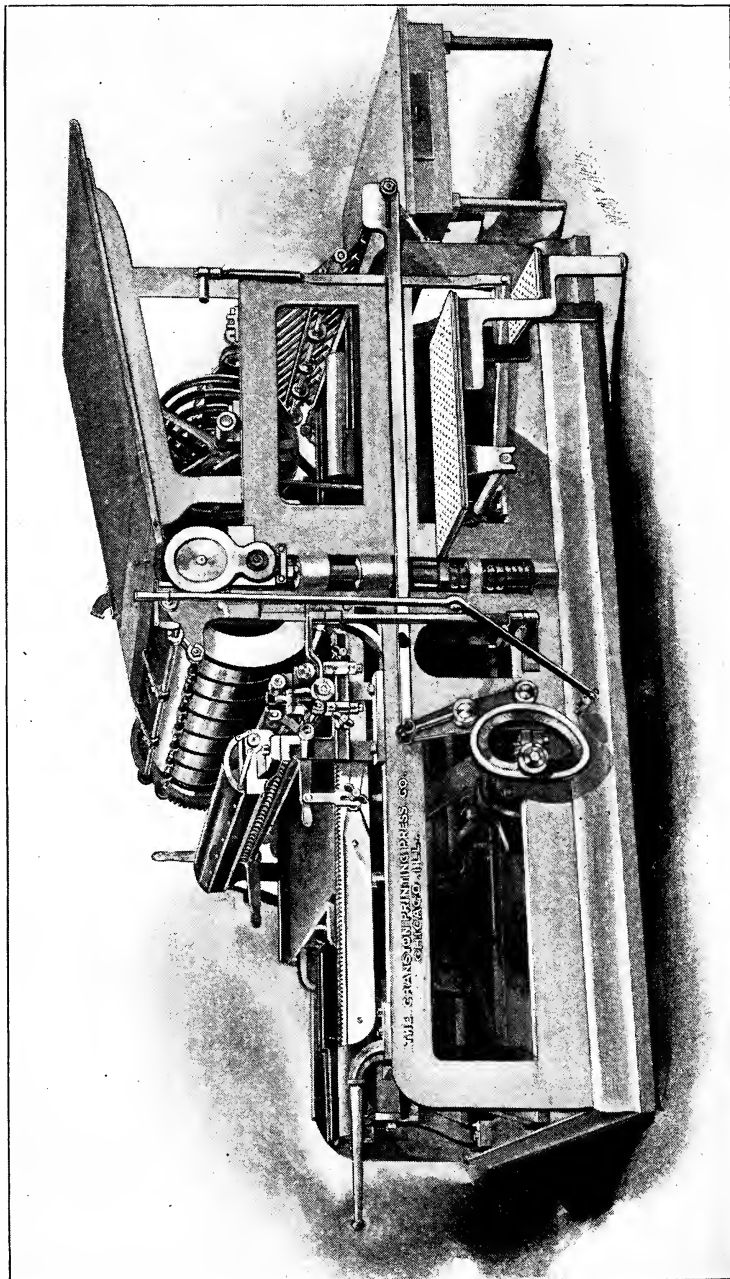

**THE CRANSTON-VICTOR TWO-REVOLUTION PRESS.**

**Two-Roller.**

*See illustration on opposite page.*

The track has wide runners, laid with steel. The table has three supports—two in the track, one on a center bearing placed on the girt—thus giving three continuous bearings through the line of impression without interference of a third track. Cylinder and lifting shafts, rolls, shoes, knuckles, are of steel. The smaller parts are built with a view to the greatest possible wear.

The mechanism for lifting the cylinder is simple, effective, and controlled by cam movements. No strain and no wear. Steel bearings.

The press has air springs; patent device for controlling motion of sliders; all gears and racks have wide faces, and are cut from the solid; distribution unailing; large size form rollers, with bearings convenient and secure, easily placed in position and as easily removed; fly cam with continuous surface; deep fountain basin; arrangement for adjusting fountain roll; cover for fountain; adjustable bearers; hardwood feed table; patent improved feed guides and side-guide leaf on feed table; patent stop and reversing motion; automatic leaf-lifting device for preventing the tongues or guides from catching and tearing the tympan while reversing press; arrangement for throwing reel wheels on or off while making ready.

The movements are all conveniently and easily adjusted, and positive in their action.

The speed of this press is all that can be obtained from any press of corresponding size and style.

Size.	Inside Bearers.	Matter Covered.	Length of Base.	Width of Base.	Weight, Boxed.	Price.
No. 4	. 34×50 in.	. 30×46 in.	. 8 ft. 6 in.	. 5 ft. 7½ in.	. 14,500	. . . . .
No. 5½	. 38×54 in.	. 34×50 in.	. 9 ft. 6½ in.	. 5 ft. 11½ in.	. 16,000	. . . . .
No. 6	. 42×60 in.	. 37×56 in.	. 10 ft.	. 6 ft. 3 in.	. 17,500	. . . . .

Each press is furnished with overhead fixtures complete, blanket or hard packing, wrenches, iron steps, two complete sets stocks—one set cast with composition ready for immediate use.

**The Cranston Presses.**

These presses have always been built on high-grade lines. The motto of the maker, painted conspicuously in the factory, "First learn to do a thing well, then learn to do it quickly," has been consistently carried out, and it can safely be affirmed that the Cranston presses are unexcelled in fine workmanship, true mechanical principles, and superior materials, all which result in durability, smoothness, and general satisfaction. The new series of 1897 have numerous up-to-date improvements, and some sizes have been changed for the better convenience of printers. The numerous users of Cranston presses will be more than pleased with the new series.

**THE CRANSTON-VICTOR COMMERCIAL PRESS.**

**Two-Revolution, with Four Rollers.**

*For description, etc., see opposite page.*

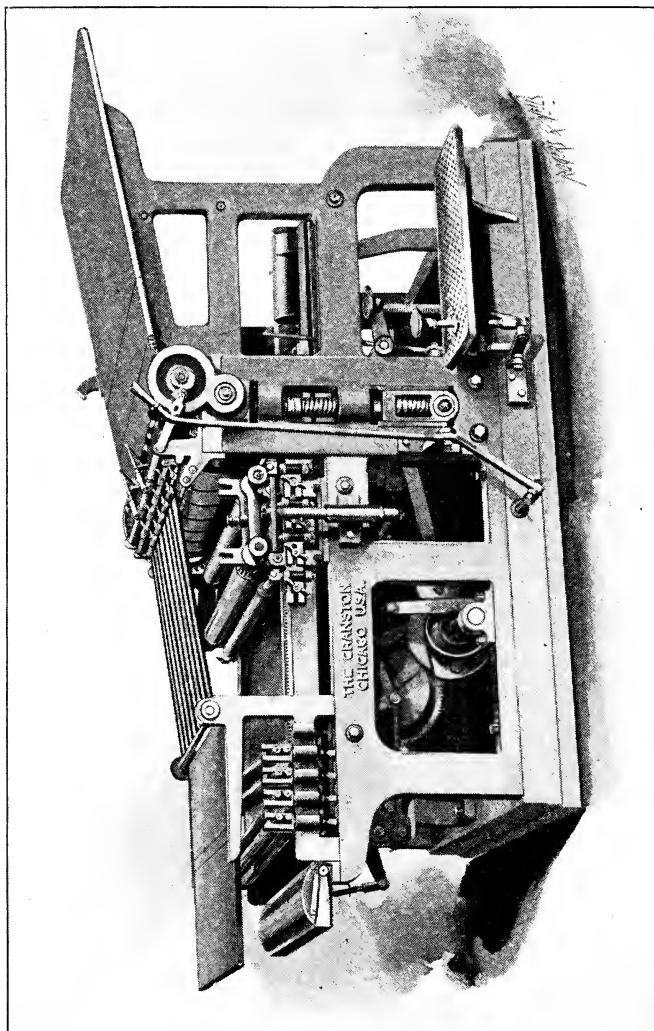



**THE CRANSTON-VICTOR COMMERCIAL PRESS.**

**Two-Revolution, with Four Rollers.**

*See illustration on opposite page.*

Various methods of engraving having been developed, and their utility practically demonstrated, the demand has been created for a press that will bring out delicate lines of half-tone, process, etched, photo-engraved plates, and work of this description, giving that clear and distinct impression without which the best results are not attainable from such plates. The new Victor Two-Revolution Four-Roller Commercial Press is especially designed for this class of work. Possessing as it does the patented features of our larger sizes, it is, like them, solidly constructed, giving an *unyielding impression* and an *ample inking surface*. Its size is convenient and sufficiently large to meet all demands for work of this class, while the speed provides for rapid production. Many features are embodied in this press for convenience in make-ready, etc. The distribution is a complete system, by means of which every particle of inking surface is *evenly* and *thoroughly* covered. The movements are easily adjusted and positive in their action. The cam has a continuous surface and the sheets are laid lightly on the table without smut or offset. Adjustable fly-fingers. The height of the press is such that it can be fed from the floor, and it is built with special reference to convenience in working about it. Its register is *faultless*. This press is the result of careful study, and embodies suggestions from practical printers regarding the requirements for printing this special work. The very satisfactory results obtained from those in use prove conclusively that the Victor will meet all requirements made upon it.

The speed is equal to all reasonable demands for fine printing.

Size.	Inside Bearers.	Matter Covered.	Length of Base.	Width of Base.	Weight, Boxed.	Price.
No. 2A	. 25×38 in.	. 22×34 in.	. 6 ft. 5¼ in.	. 4 ft. 5¼ in.	. 7500 lbs.	. . . . .

Each press is furnished with overhead fixtures complete, blanket or hard-packing, wrenches, two complete sets stocks.

**A Wise Purchase.**

The No. 2A Cranston-Victor Press is a money-maker. Fine job printing, from small circulars to any size within its capacity, can be done at high speed and with the finest results. In a printing establishment doing general work of all grades this press will prove exceedingly useful and profitable. Its construction and features are such that making ready can be done quickly. It takes in a great range of work which cannot be so profitably printed on a larger press.

THE CRANSTON-VICTOR FOUR-ROLLER TWO-REVOLUTION PRESS.

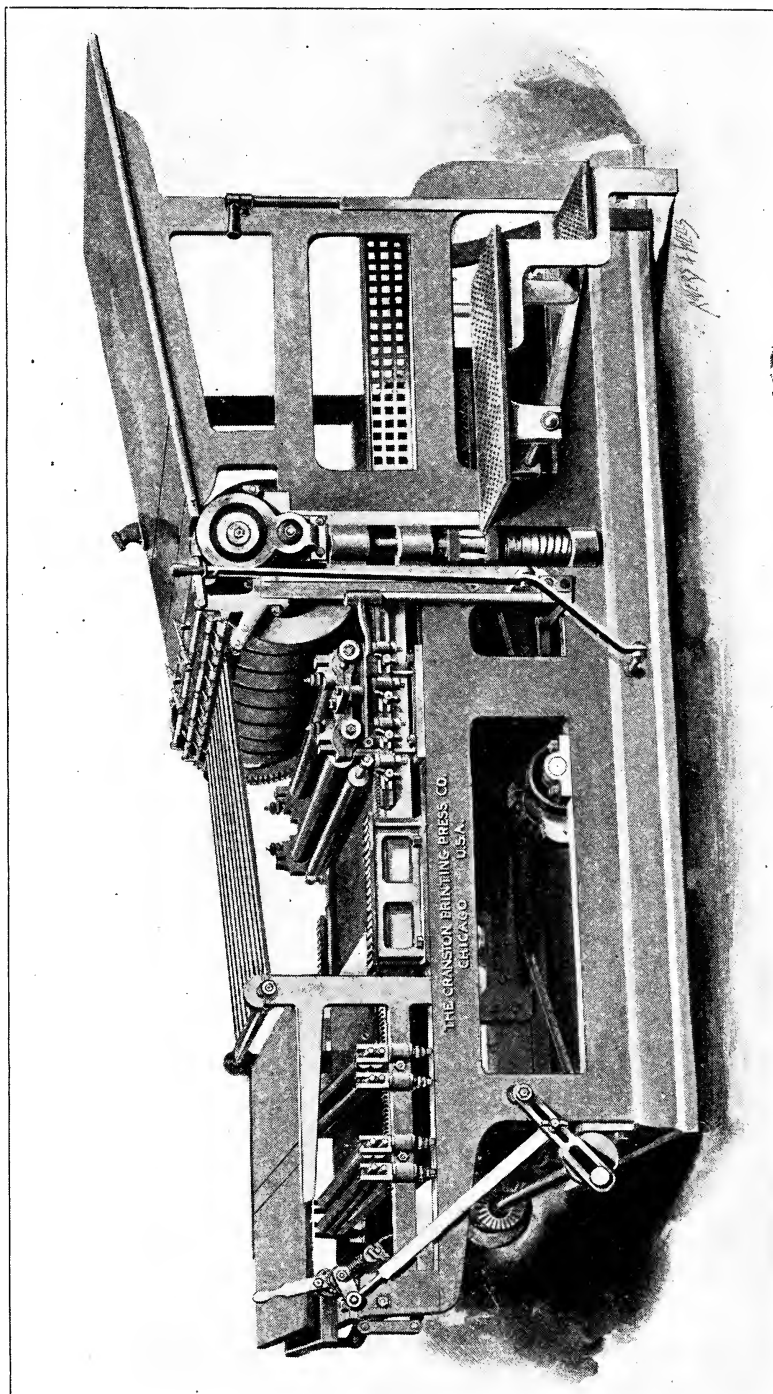

**THE CRANSTON-VICTOR TWO-REVOLUTION PRESS.**

**Four-Roller.**

*See illustration on opposite page.*

The entire frame of the press is solid and compact. The tracks on both the table and runners are wide, laid with steel, and the rolls traversing on them are of the same material accurately gauged to size. The lifting mechanism for the cylinder is a direct cam motion, plain in construction, smooth running, operated with light power, requiring no weight. The shafts, cams, knuckles, studs, rolls, shoes, and all wearing parts, are of steel, and built with view of greatest possible resistance to wear. The shoes are securely fastened and doweled to the rack hangers. The cylinder has heavy flanges. The impression surface is strongly braced and supported. The press has hard-wood feed table; fly cam with continuous surface. Ample provision is made securing distribution and register.

This is a press that can be easily handled, with movements plain and direct in action, adjustments readily and conveniently made, resulting in the greatest economy of time and labor.

This press is provided with a trip, which may be thrown on or off at any point of the stroke of the bed.

The reciprocating motion of the table is controlled by air springs which are simple and effective, having a plain valve which is in itself direct acting without any complicated attachments. The sheets are delivered to the fly by the tapeless delivery. The down-delivery attachment gives a positive and un failing delivery of sheets on the fly table.

As far as practicable on all our presses, the adjustments are made with thumb nuts.

The sliders are attached to the table by our patent slider motion, and uniformity in travel thereby insured.

The patent feed guides and adjustable side-guide leaf on feed table can be adjusted with the utmost precision without leaving the feeder's platform. Reel wheels are readily thrown on or off while making ready.

The patent stop and reversing motion enables the feeder to stop the press instantly at any desired point, and run it backward, thereby effecting economy of time and labor, as he has absolute control of the press without leaving his position.

The automatic leaf-lifting device prevents the tongues or guides from catching or tearing the tympan while reversing press.

Size.	Inside Bearers.	Matter Covered.	Length of Base.	Width of Base.	Weight Boxed.	Price.
No. 4 . . .	34 × 50	29 × 46	9 ft. 6½ in.	5 ft. 7½ in.	17,500	. . .
No. 5½ . . .	38 × 54	34 × 50	9 ft. 6½ in.	5 ft. 11½ in.	18,500	. . .
No. 6 . . .	42 × 60	37 × 56	10 ft.	6 ft. 3 in.	19,500	. . .

Each press is furnished with overhead fixtures complete, blanket or hard packing, wrenches, iron steps, two complete sets stocks—one set cast with composition ready for immediate use.

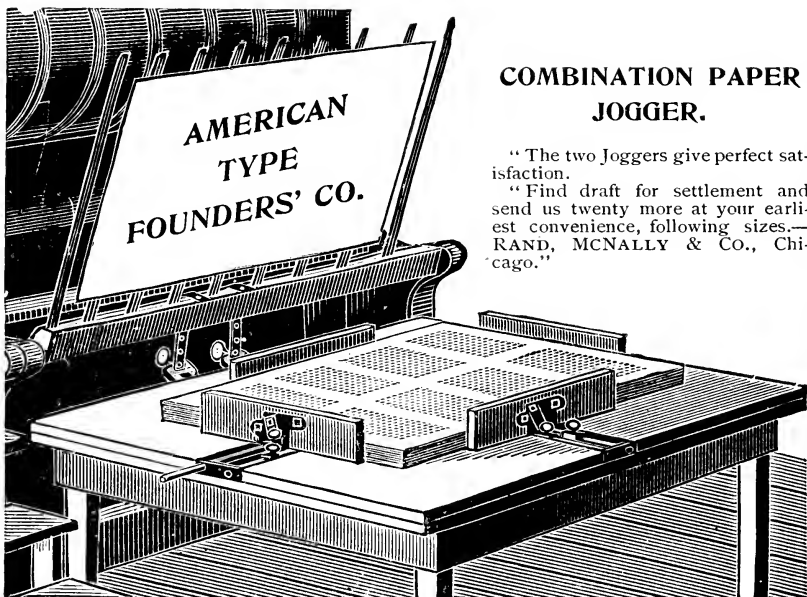

**COMBINATION PAPER JOGGER.**

“ The two Joggers give perfect satisfaction.  
 “ Find draft for settlement and send us twenty more at your earliest convenience, following sizes.—  
 RAND, MCNALLY & Co., Chicago.”

Made with wings, to be instantly removed if desired. No projecting rod on front side to tear clothes. This of itself is worth the price of a Jogger. Patent attachable wings for small joggers, by which letter-heads, etc., can be evened up.

24×36 inches, or less . . . . .	\$15.00	Larger than 36×48 inches .	\$20.00
36×48 “ “ . . . . .	18.00		

**OVERHEAD POWER FIXTURES**

Consisting of countershaft, two adjustable hangers with oil cups, two cone pulleys, and driving pulley for main shaft.

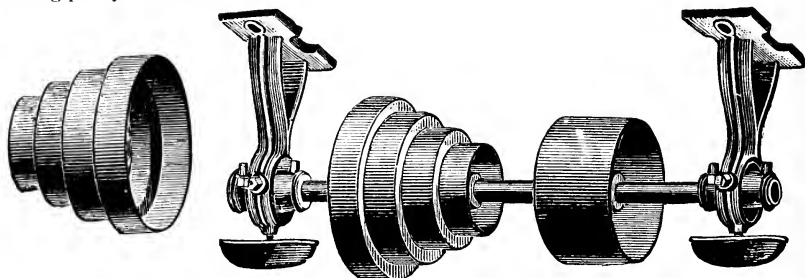

**Light Fixtures for Eighth-Medium Presses and Smaller.**

No. 1—3 speed, 6 to 9 inches, belt 1½ inches . . . . .	\$15.00
No. 2—4 speed, 7 to 10 inches, belt 1¾ inches . . . . .	18.00

**Heavy Fixtures.**

No. 3—3 speed, Eighth Medium . . . . .	20.00
No. 4—4 speed, Eighth Medium . . . . .	22.50
No. 5—3 speed, Quarto Medium . . . . .	22.50
No. 6—4 speed, Quarto Medium . . . . .	25.00
No. 7—3 speed, Half Medium . . . . .	27.50
No. 8—4 speed, Half Medium . . . . .	30.00

Shafting, Hangers, Pulleys and Collars furnished to order at the lowest prices. For Belting, see page 831.

**TRIBUNE NEWSPAPER FOLDER.**

All Iron Frame. Working parts Steel and Iron. All Movements Positive. No Sprocket Chains. No Lost Motion.

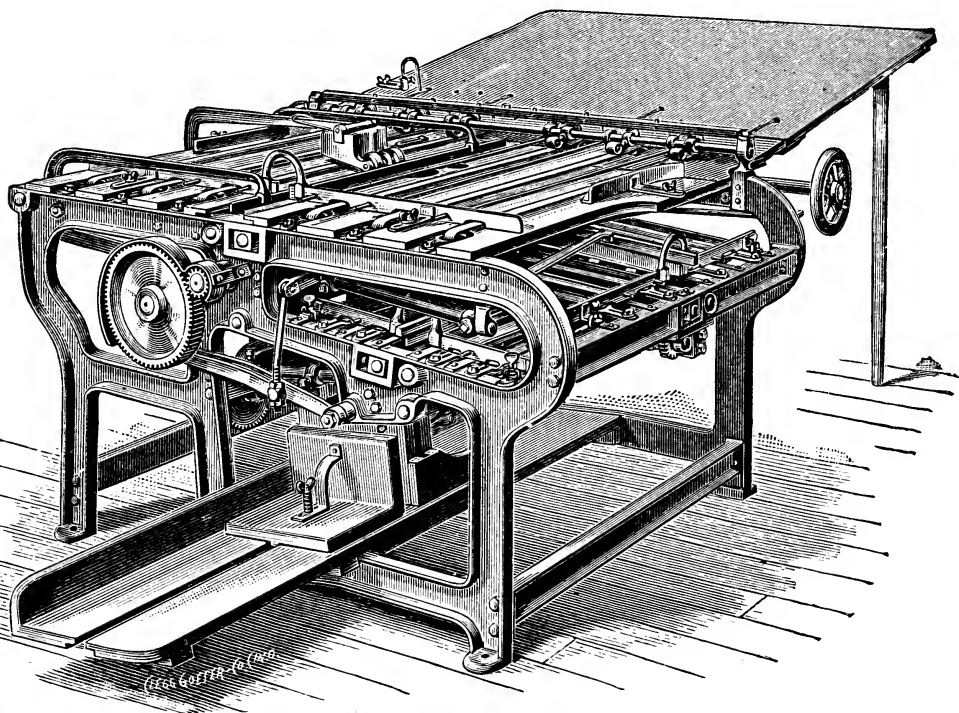

This is a folder of the highest grade of construction and efficiency, without a superior for its purpose on the market, and sold at such moderate net prices as to make so-called "cheap" folders highly expensive in comparison—durability and reliability considered. It has no make-shift devices. It folds on the same principle as the high-grade book machines. The simplest folder made.

Made in one size only, 36×48 inches, which takes in any size sheet, whether folio or quarto, from 22×32 to 36×48 inches. Paster and trimmer can be furnished at time of purchase or added afterward. Made with three- and four-fold deliveries. Three-fold work is delivered in a receiving box, while four-fold work is delivered in a packer, as shown in illustration.

In the hands of a competent operator it will fold ordinary sixteen and thirty-two page work.

Weight about 900 pounds. Power required, about one-tenth of one horse power. Speed, 3000 folio or quarto sheets per hour.

**List Prices.**

For hand feed . . . . .	\$400.00
Paster and Trimmer . . . . .	25.00
Fixtures for attaching to press, net . . . . .	50.00 extra.
Two and four-page inseting attachment, net . . . . .	100.00 extra.
Two and four-page covering attachment, net . . . . .	100.00 extra.
Circulars and discounts on application.	

UNIQUE IRON-FRAME FOLDER.

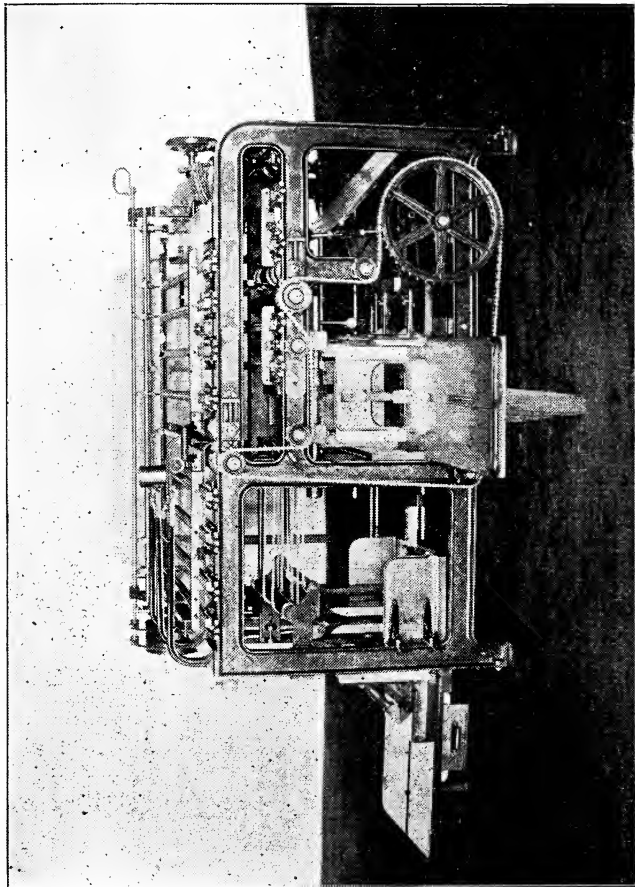

Built by the maker of the Bennett Economical Folder, shown on opposite page, to overcome the objections to wood-frame folders.

For hand feed or attachable to any cylinder press, front or back delivery.

- To fold sheet 32x44 inches, three- and four- fold, with Paster and Trimmer for eight-page work . . . . \$300.00
- To fold sheet 36x50 inches, three- and four- fold, with Paster and Trimmer for eight-page work . . . . 300.00
- Folio Inserting Attachment . . . . 60.00
- Quarto Inserting Attachment. . . . 100.00
- Folio and Quarto Inserting Attachment, combined . . . . 125.00
- Quarto Covering Attachment . . . . 100.00
- Fifth or Post-Office Fold . . . . 75.00
- Hand Feed and Attachable in one machine . . . . . 50.00
- Attachments for Front-Delivery Press . . . . . 25.00

Floor space of 32x44-inch folder is 40x56 inches; of 36x50-inch folder, 46x62 inches.

**BENNETT ECONOMICAL FOLDER.**

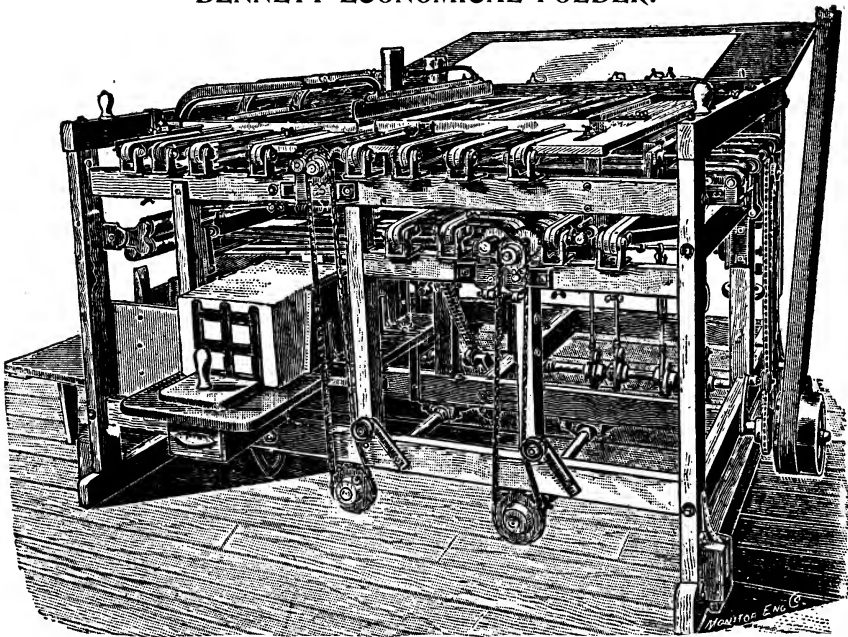

Has a strong, wooden frame, with working parts of iron. Delivers at third and fourth folds, and can be changed without stopping machine. Has pasting and trimming attachment for eight (8) page work. Built in hand-feed, or attachable to any cylinder press, front or back delivery. All journals are of tool steel, with journal boxes three diameters long, hung in self-adjusting pivot hangers, making it possible to remove any fold roll, driving or rock shaft in a few moments and replace in line, and there is not a gear on the machine but can be reached conveniently, and removed easily. All adjustments are made by screw, each tape tightened independently, drop of fold blades can be regulated by the "turnbuckle" adjustment to one-hundredth of an inch. There are side guides to insure accuracy in folding, whether a sheet comes from a press or feed-board.

No extra charge for press fixtures in attachable machines, except for front-delivery press.

32x44 (6-Column Quarto), or 36x50 (7-Column Quarto), including Paster and Trimmer . . . . .	\$240.00
Folio Supplement Attachment, with Paster . . . . .	50.00
Quarto Supplement Attachment, with Paster . . . . .	85.00
Folio and Quarto Supplement Attachment, combined . . . . .	125.00
Cover Attachment for eight pages . . . . .	100.00
Fifth or Post-office Fold . . . . .	50.00
Hand Feed and Attachable in one machine . . . . .	50.00
Attachments for Front-Delivery Press . . . . .	25.00

**THE BENNETT COUNTRY QUARTO FOLDER.**

This machine is exactly the same as the Economical Folder, except that, instead of regular packing boxes at the third or fourth fold, it has a packing box at the fourth fold and a drop box at the third fold.

6 or 7-Column Quarto, including Paster and Trimmer . . . . .	\$200.00
Hand feed or attachable to press.	

**HERCULES SPECIAL GAS AND GASOLINE ENGINE.**

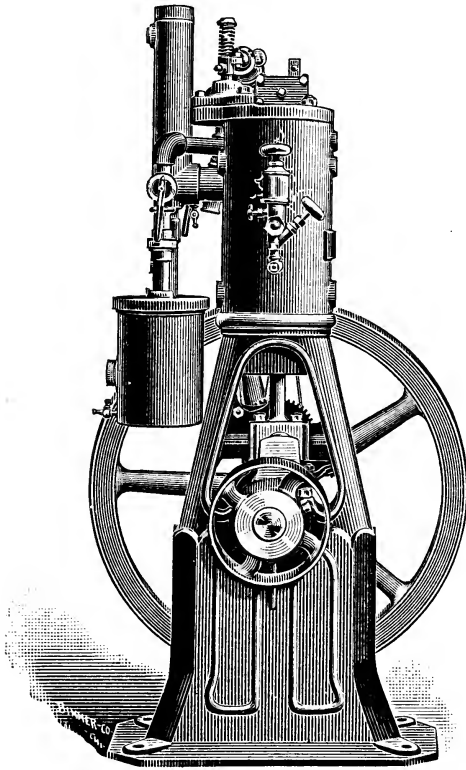

2½ horse power Hercules Special Gas Engine.

The superiority of a good gas engine to a steam engine in economy, convenience, safety, cleanliness and availability at a moment's notice is conceded by all, and more especially in offices where the use of power is intermittent; because with steam power, if used only at short intervals during a day, steam must always be kept up, and the fire and boiler constantly watched, while with a gas engine one turn of the wheel and your power is available, and when done with all expense ceases. With the gas engine there is no dirt, no coal, no engineer, no noise, no smoke, no annoyance, no danger.

The Hercules Special is a modern gas engine, built on the same substantial and durable lines as a first-class steam engine, held in a solid, heavy frame of No. 1 grade iron, with all working parts of bronze or forged steel, highly finished, with automatic governor, sight feed lubricators, and adjustable oilers.

The principle of construction is designed to get the maximum power with the minimum consumption of

gas, and the consumption is automatically regulated to correspond with the power used. If only ½-horse power is used, then the consumption of gas is about one-fifth as much as if the maximum power of the engine was in use. The consumption of gas is about fifteen cubic feet per horse power (actually used) per hour.

The gas is ignited by either an electric spark generated by the contact of two heavy, hardened steel electrodes, which are easily adjusted while engine is running, or by means of a heated metallic tube, or by both methods.

**When Used as a Gasoline Engine.**

The gasoline, which may be of a cheap grade (74° test), is fed from a tank placed at a distance, and connected with the gas chamber on the side of engine. The gas passes into the mixing valve, and combines with the requisite quantity of hot air to secure perfect combustion, full power, and no smell. Full directions for making and placing gasoline tank and connecting same are sent with the engine. The gasoline engine consumes about one-eighth of a gallon of gasoline per horse power per hour, and the consumption is in proportion to the power used.

2½ horse power (actual) . . . . . \$185.00

Send for descriptive circular.

When required, the Hercules is supplied with the necessary appliances for operating by both gas and gasoline.



**EMMERICH BRONZING MACHINE.**

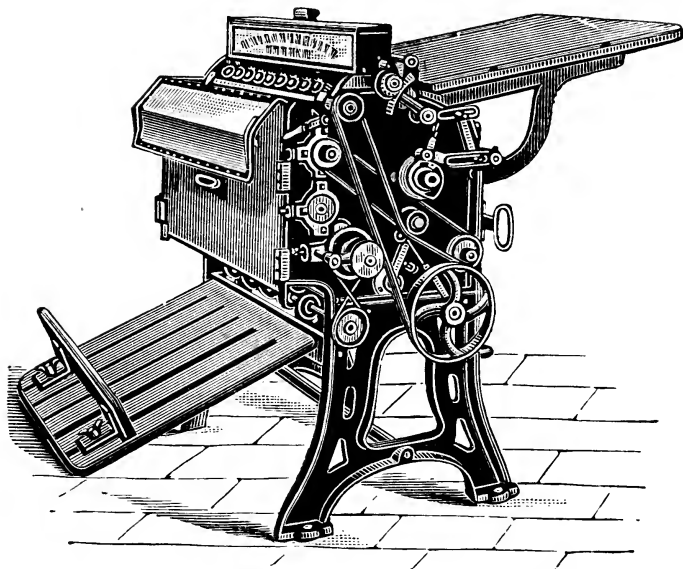

Over one thousand of these excellent machines are in use, and all give satisfactory results. They apply the bronze, polish and remove the superfluous powder, and deliver the sheet, bronzed side up, at a speed of two thousand on the smaller sizes. They are self-adjusting for all thicknesses of paper. They are made to be belted to a main shaft, and are equipped with belt shifter and tight and loose pulleys.

No.	Maximum Capacity.	Floor Space.	Weight Pounds.	Speed of Driving Pulley.	Diameter Driving Pulley.	Price f. o. b. factory.
1 . . .	9×15 . . .	24×30 . . .	320 . . .	330 . . .	6 inches . . .	\$300.00
2 . . .	14×25 . . .	30×37 . . .	390 . . .	360 . . .	6 inches . . .	375.00
3 . . .	16×30 . . .	44×50 . . .	600 . . .	110 . . .	10 inches . . .	475.00
4 . . .	20×35 . . .	48×54 . . .	750 . . .	105 . . .	10 inches . . .	550.00
5 . . .	25×40 . . .	54×58 . . .	900 . . .	90 . . .	10 inches . . .	650.00
6 . . .	28×44 . . .	57×60 . . .	1050 . . .	140 . . .	13 inches . . .	750.00
7 . . .	34×50 . . .	62×65 . . .	1225 . . .	140 . . .	13 inches . . .	850.00
8 . . .	36×54 . . .	65×70 . . .	1350 . . .	140 . . .	13 inches . . .	925.00

**EMMERICH CARD BRONZING MACHINE.**

Specially constructed for bronzing heavy stock that will not conform to a cylinder, such as photograph mounts, thick cards, etc. Both sides of cards are dusted at one operation. Forty photograph mounts per minute is the speed.

No.	Maximum Capacity.	Floor Space.	Weight Pounds.	Speed of Driving Pulley.	Diameter Driving Pulley.	Price.
1 . . .	10 in. . . .	24×34 . . .	350 . . .	200 . . .	8 inches . . .	\$ _____
2 . . .	14 in. . . .	28×37 . . .	420 . . .	200 . . .	8 inches . . .	_____
3 . . .	20 in. . . .	34×40 . . .	525 . . .	175 . . .	10 inches . . .	_____
4 . . .	24 in. . . .	38×45 . . .	650 . . .	175 . . .	12 inches . . .	_____

Prices will be quoted upon receipt of sample or description of work to be done.

FOR STOCK ROOM AND BINDERY.

PEERLESS GEM PAPER CUTTER.

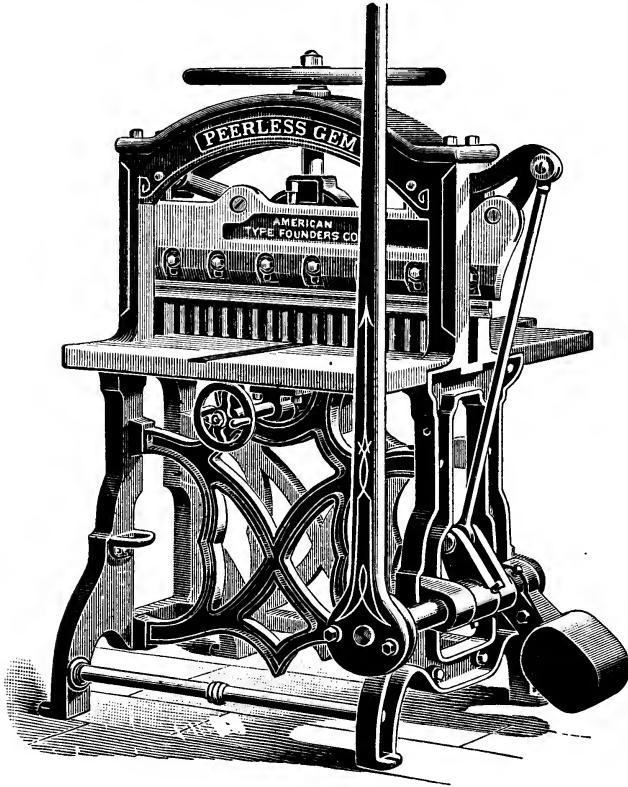

Superior in every detail and in the leverage, cutting with greater ease to operator, and returning from cut with the least possible exertion, owing to their perfect balance. The frame is stronger, heavier and better braced; the knife thicker and deeper, insuring a truer cut and longer life; the lever is adjustable; the balance weight is now hung inside the frame, thus saving floor room. There are split back gauges, side gauges, and a front enameled measuring gauge. Unexcelled in construction, materials used, and finish.

Compare details of construction given below with those on other cutters.

30-inch, cuts 30 $\frac{1}{4}$ inches . . . . .	\$175.00
32-inch, cuts 32 $\frac{3}{4}$ inches . . . . .	200.00

Details of Construction.

	Weight, Unboxed.	Thickness of Knife Bar.	Thickness of Knife.	Depth of Knife.	Diameter of Lever Shaft.	Diameter of Connection Shaft.	Steel Lever
30-inch . . .	1340 lbs.	1 $\frac{3}{4}$ in.	$\frac{1}{2}$ in.	5 in.	2 in.	1 $\frac{1}{2}$ in.	
32-inch . . .	1425 lbs.	1 $\frac{3}{4}$ in.	$\frac{1}{2}$ in.	5 in.	2 in.	1 $\frac{1}{8}$ in.	

PEERLESS GEM PAPER CUTTERS.

**23-INCH  
PEERLESS GEM  
CUTTER.**

No other cutter of this size, or about this size, equals the new 23-inch cutter. It weighs 725 pounds, unboxed; has  $4\frac{1}{2} \times \frac{3}{8}$ -inch knife, and  $1\frac{3}{4}$ -inch knife bar. Built on the Peerless-Gem principle, it has leverage of maximum power and easy return, and all the features of the 25-inch Peerless Gem Cutter. It is not possible to build a better cutter for the money asked.

The balance weight is hung inside the frame, thus saving floor space and removing an annoying obstruction.

23-inch, cuts  $23\frac{1}{4}$  in. . . \$100.00

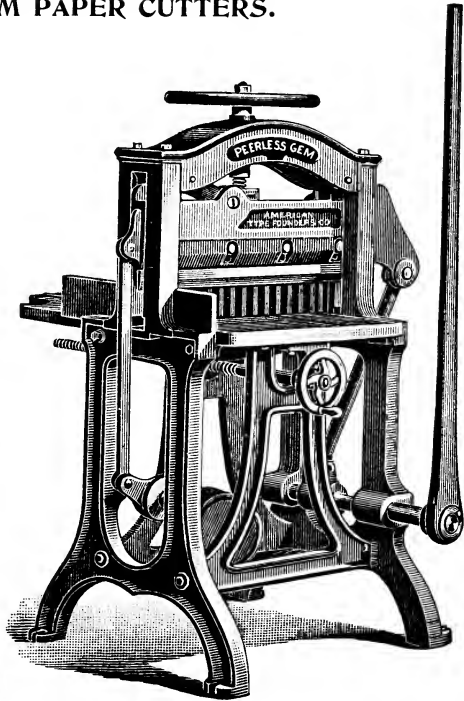

Style of 23-inch Peerless Gem Cutter.

**25-INCH  
PEERLESS GEM  
CUTTER.**

Excels all other cutters of its size in weight, ease of cut, strength, durability and finish. It is built on the same design as the Peerless Gem in all points, except that the lever is fixed instead of movable. The weight is 825 pounds, unboxed; has  $4\frac{1}{2} \times \frac{3}{8}$ -inch knife;  $1\frac{3}{4}$ -inch knife bar. The best money's-worth ever offered in a 25-inch paper cutter.

The leverage both while cutting and returning is perfect, reducing the exertion of cutting to a minimum.

The balance weight is hung inside the frame to save floor space.

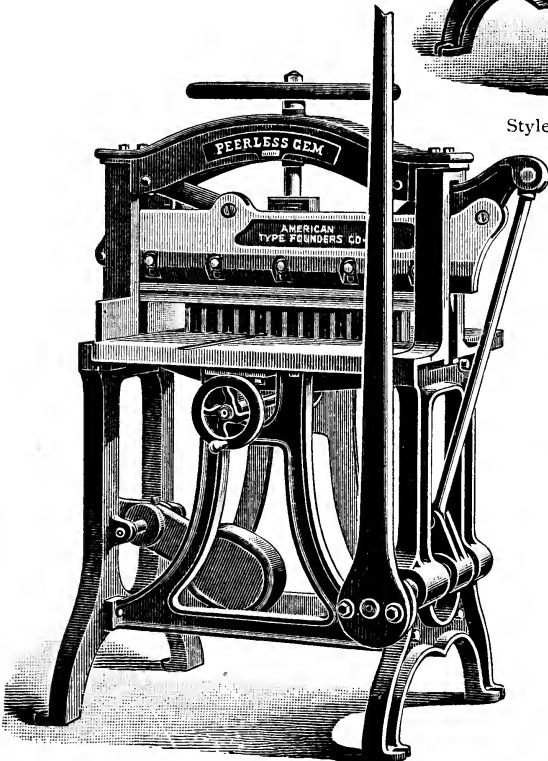

Style of 25-inch Peerless Gem Cutter.

25-inch, cuts  $25\frac{1}{4}$  in. . . \$125.00

**CLIPPER  
PAPER  
CUTTER.**

Designed for cutting small work, such as labels, circulars, etc. Has a patented reversible clamp, which cuts very narrow strips and leaves no marks on the paper. The lever is pulled forward to cut. Quality of construction is A1.

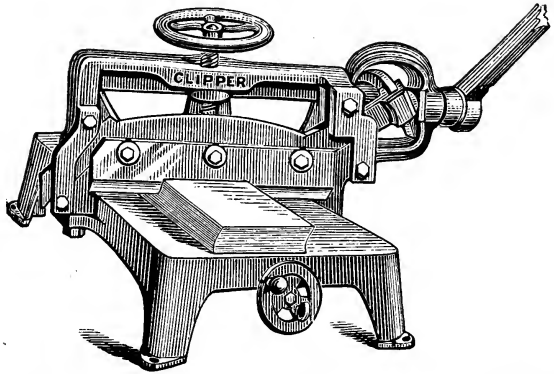

Cuts and squares 12 inches . . . . . \$40.00

**UTILITY PAPER CUTTER.**

**With Iron Stand.**

Iron stands are made for each size, and are recommended where bench room should be saved.

A thoroughly well-built cutter, without a superior of its size. Has side and back gauges, and a patent reversible clamp which cuts very narrow strips without marking the paper.

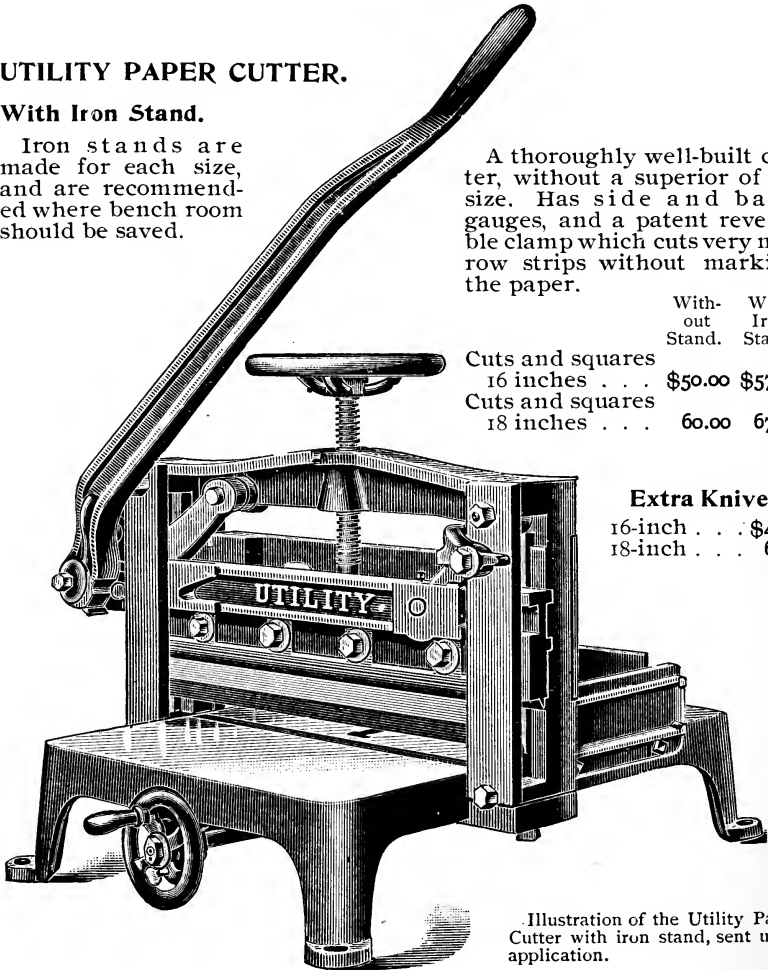

	With-	With
	out	Iron
	Stand.	Stand.

Cuts and squares		
16 inches . . .	\$50.00	\$57.00
Cuts and squares		
18 inches . . .	60.00	67.00

**Extra Knives.**

16-inch . . .	\$4.50
18-inch . . .	6.00

Illustration of the Utility Paper Cutter with iron stand, sent upon application.

**CHANDLER & PRICE  
PAPER  
CUTTER.**

Of modern and strong construction, and built by one of the most reliable builders of printing machinery in the world. Has interlocking back gauge and clamp, and gauges to a half inch from the cutting edge of the knife. Has side gauges and adjustable lever.

26-inch . . . . . \$130.00  
30-inch . . . . . 175.00

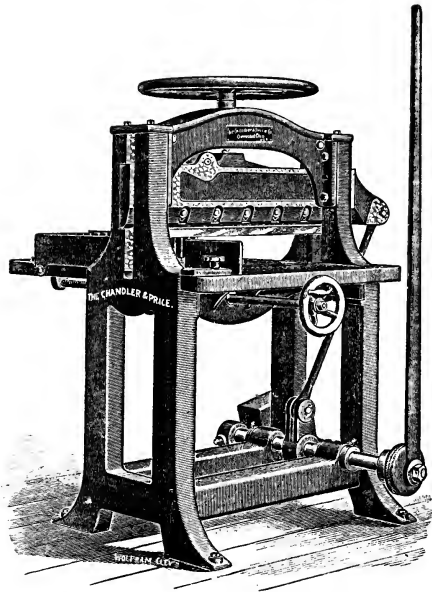

**RELIANCE LEVER  
PAPER CUTTER.**

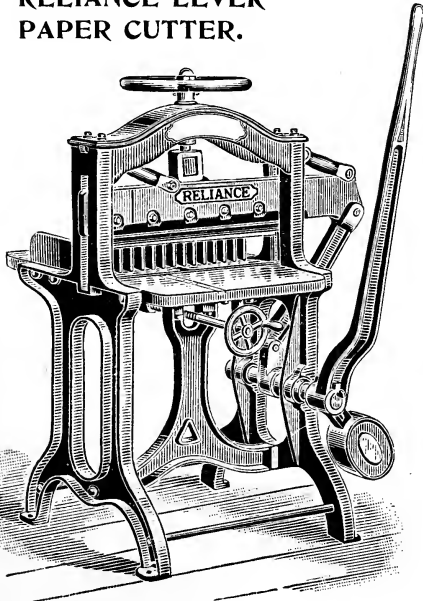

23-inch . . . . . \$90.00  
25-inch . . . . . 110.00  
28-inch . . . . . 135.00

**ADVANCE LEVER  
PAPER CUTTER.**

Its special feature is the arrangement for taking up the wear in slideway, in which the knife bar moves, by means of steel gibs controlled by set screws.

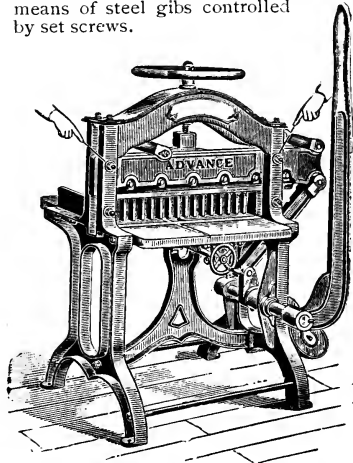

22½-inch . . . . . \$90.00  
25-inch . . . . . 110.00  
30-inch . . . . . 165.00  
33-inch . . . . . 200.00

ADVANCE POWER CUTTER.

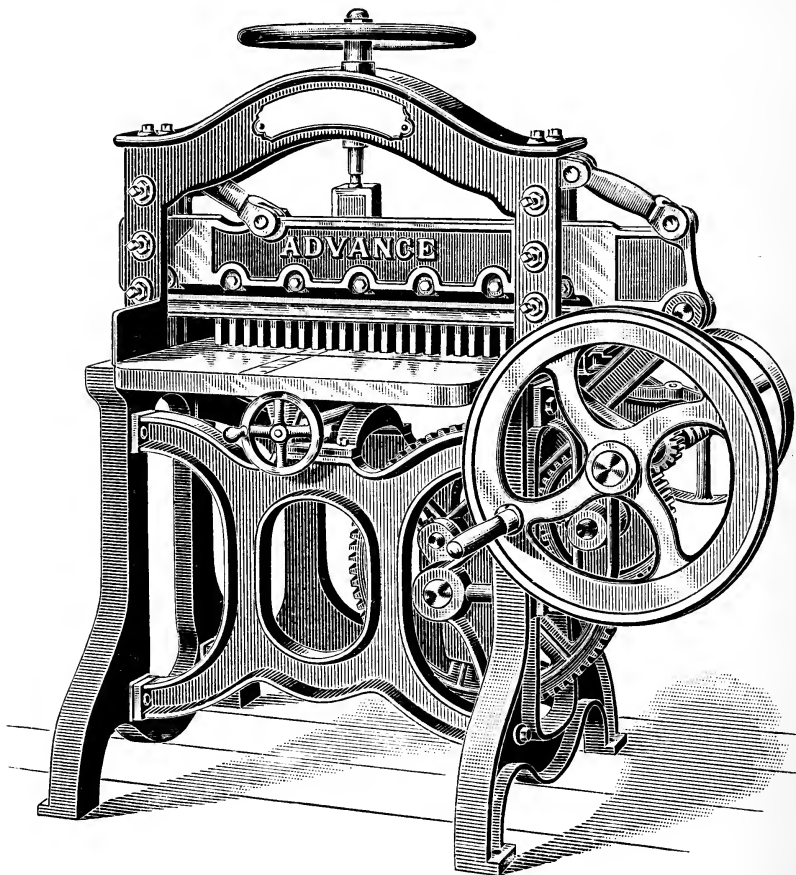

The Advance Power Cutter is fitted for hand or steam, is solidly built, the frame is firmly stayed by two substantial cross-braces, upon which is bolted the arch that supports the center of the bed, making it perfectly rigid and firm under pressure of clamp or knife. It is fitted with the interlocking back gauge and clamp, by which paper may be cut to within half an inch of the knife. It has brass figured rules in bed, back and front. The throw-off is automatic and stops the knife instantly; it may be thrown off at any point, thus obviating possible waste of paper through error. The knife has a dip-cut, which will be duly appreciated by all requiring a power paper cutter.

The slideways in which the knife-bar moves is faced with steel gibs secured and adjusted by means of three set-screws on each side, so that any wear in the slideways may be taken up quite easily.

This is a very convenient style of cutter, as it will be found to be a very effective and easily operated hand power cutter at times when other power is not available.

30-inch, squares 30 inches . . . . .	\$300.00
33-inch, squares 33 inches . . . . .	350.00

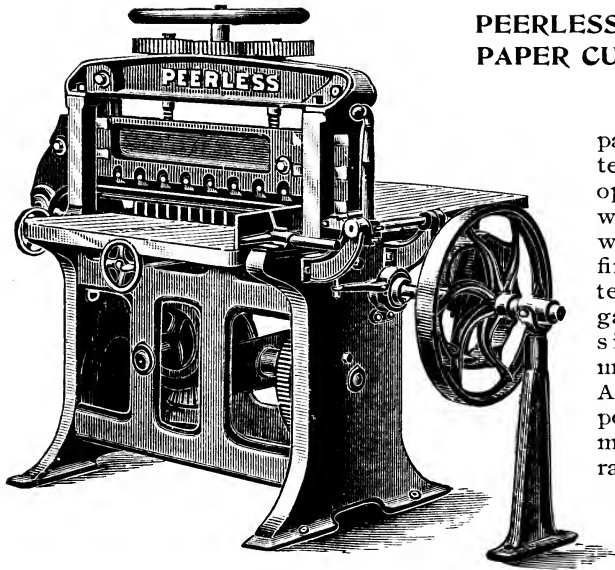

**PEERLESS POWER  
PAPER CUTTER.**

A powerful, compact, well-built cutter. The clamp is operated by two worm-screws, which give it great firmness. Has interlocking back gauges and clamp, side gauges and measuring gauge. All movements are positive, all adjustments easy and rapid.

Cuts 36 inches square . . . . .	\$650.00
Cuts 40 inches square . . . . .	800.00

**CHALLENGE  
POWER CUTTER.**

This cutter is provided with side gauges, back and front; an extra reversible side gauge for front table; split back gauge; interlocking back gauge and clamp, for cutting narrow widths; brass figured rules in bed, back and front. The slideways on which the knife bar moves are faced with gibs controlled by set screws, so that all wear in the slideways may be taken up.

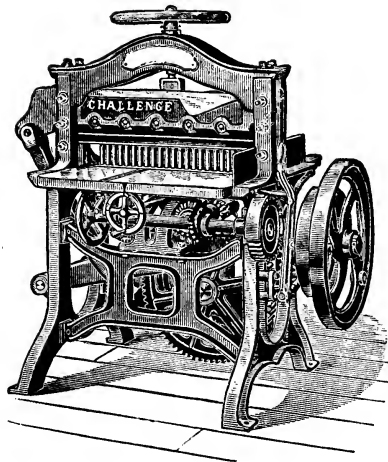

30-inch, squares 30 inches . . . . .	\$400.00
32-inch, squares 32 inches . . . . .	450.00
36-inch, squares 36 inches . . . . .	650.00
40-inch, squares 40 inches . . . . .	750.00

**BROWN'S POWER PAPER CUTTER.**  
**Self Clamp or Hand Clamp.**

This cutter is supplied with automatic clamp or with hand clamp. It is a modern cutter, immensely powerful, rapid and accurate, and has every convenience demanded on a first-class cutter. The back gauge may be had interlocking or solid, and is moved by a "rapid-transit" device. The knife can be stopped at any point. The knife may be started by lever at side or by treadle lever. Patent floating fingers attached to back gauge prevent the thinnest paper from getting under gauges, while leaving the bed free from objectionable grooves.

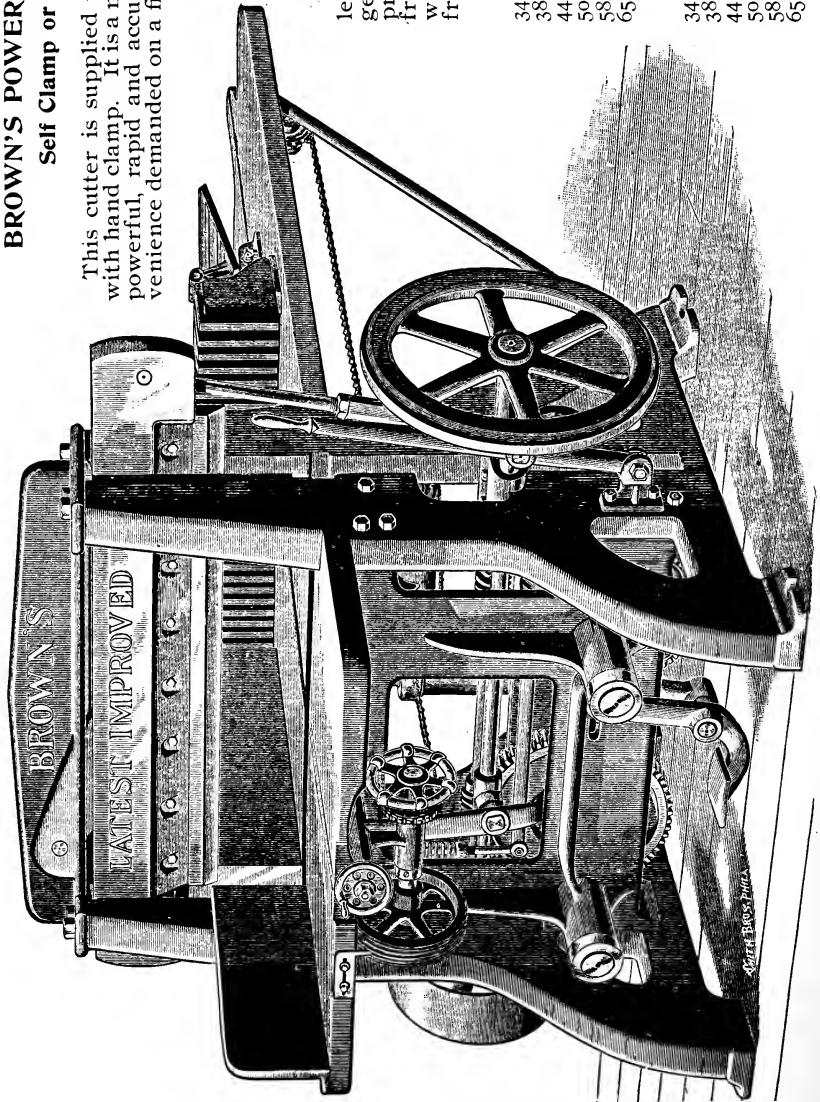

With Hand Clamp.

34 inches . . . . .	\$575.00
38 inches . . . . .	700.00
44 inches . . . . .	885.00
50 inches . . . . .	1200.00
58 inches . . . . .	1500.00
65 inches . . . . .	1800.00

With Automatic Clamp.

34 inches . . . . .	\$600.00
38 inches . . . . .	725.00
44 inches . . . . .	910.00
50 inches . . . . .	1225.00
58 inches . . . . .	1550.00
65 inches . . . . .	1850.00



SHERIDAN'S IDEAL CUTTER.

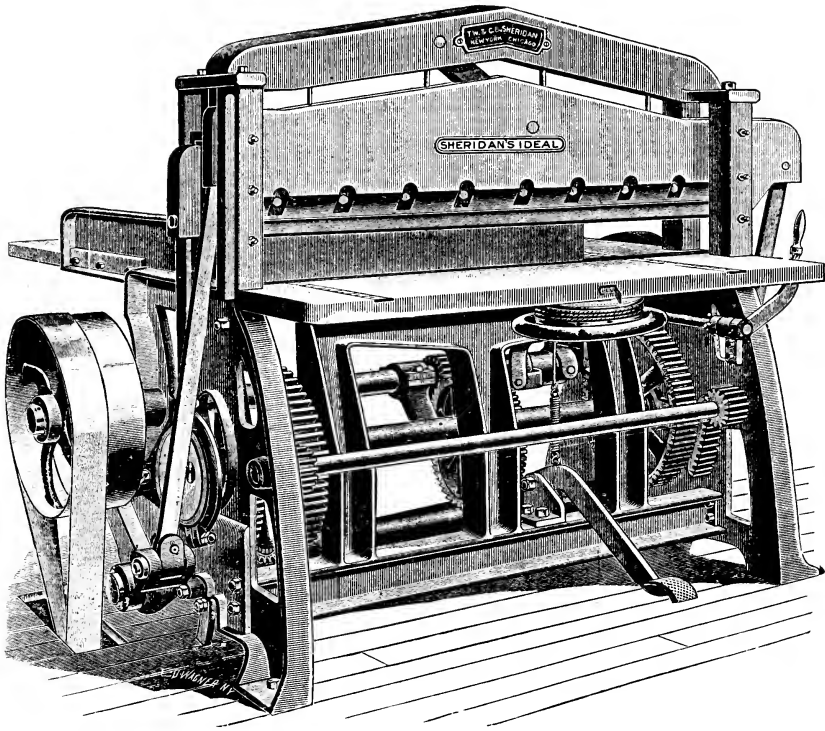

This cutter embodies the result of sixty years of labor and experience. Has all the desirable features of the well-known "Auto." Cutter, with the advantage that both clamp and knife are drawn down from both ends with no reverse motion of gear, thus securing an absolutely noiseless machine, with a positive and very powerful automatic clamp motion. All gears are cut and all shafts of steel.

Size, ins.	Weight, pounds.	Floor space.	Pulleys, inches.	Speed.	Price,	Boxing.
36	3600	6 ft. x 5 ft. 8 in.	16 x 3½	300	\$ 700.00	\$10.00
40	4800	6 ft. 6 in. x 6 ft.	16 x 3½	300	850.00	12.00
45	5100	7 ft. x 6 ft. 6 in.	18 x 4	300	1000.00	15.00
50	7200	7 ft. 6 in. x 7 ft.	18 x 4	275	1300.00	17.00
55	7550	8 ft. x 7 ft.	18 x 4	275	1450.00	22.00
60	8050	8 ft. 6 in. x 7 ft. 6 in.	20 x 4	275	1650.00	24.00
65	9000	9 ft. x 8 ft.	20 x 4	275	1850.00	27.00
70	9400	9 ft. 5 in. x 8 ft. 6 in.	20 x 4	275	2100.00	30.00

THE SHERIDAN POWER CUTTER.

Hand Clamp.

Size.	Price.	Boxing.	Size.	Price.	Boxing.
33 inches . . . . .	\$550.00	\$ 9.00	48 inches . . . . .	\$1000.00	\$17.00
36 inches . . . . .	650.00	10.00	53 inches . . . . .	1200.00	20.00
39 inches . . . . .	725.00	12.00	56 inches . . . . .	1400.00	22.00
43 inches . . . . .	800.00	13.00	63 inches . . . . .	1800.00	25.00
46 inches . . . . .	900.00	15.00			

**AUTOMATIC KNIFE GRINDER.**

Knife grinders have become a necessity in large printing offices, as well as in offices remote from grinding establishments, as in the latter the saving not alone of the cost of grinding, but of expressage, delays, and extra knives will very soon pay for the cost of a knife grinder.

Two styles are made. In the light pattern, as illustrated on this page, the slide or knife holder is moved by hand against the emery wheel, which is turned by power.

The weight of the 32-inch size is 550 pounds, boxed. The tight and loose pulleys are six inches in diameter, and should run at 1100 revolutions per minute.

The grinder is adjustable for flat or concave grinding. The emery wheels are eight inches in diameter with three and one-half inch face, and can be used up almost entirely. Extra wheels cost \$4.00 each, net.

In ordering light or heavy pattern grinders it is necessary to send accurate description of knives to be ground. Knife holders are made to suit any knife without extra charge.

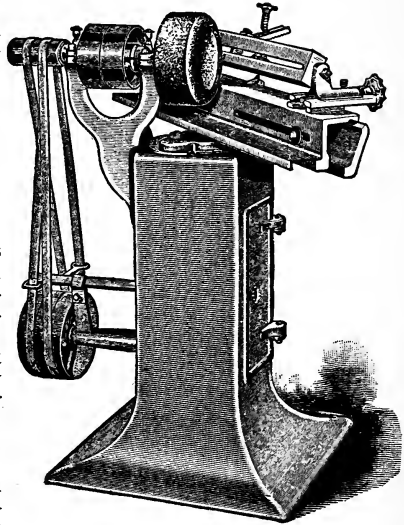

Style of Light Pattern Grinder.

**Net Prices of Light Pattern (Style B) Grinders.**

To grind knives up to 26 inches, complete . . . . .	\$ 75.00
To grind knives up to 32 inches, complete . . . . .	85.00
To grind knives up to 44 inches, complete . . . . .	105.00
To grind knives up to 54 inches, complete . . . . .	130.00
To grind knives up to 60 inches, complete . . . . .	140.00
Attachments, for water, extra . . . . .	10.00

**HEAVY PATTERN AUTOMATIC KNIFE GRINDER.**

In this style the knife holder is moved by power, and reverses automatically. The knife holder can be set at different angles from the emery wheel, which has a flat face with the corners rounded off. If the bed is set at a right angle to the emery-wheel spindle, the knife moves back and forth against the face and is ground a flat bevel; if it is set at any other angle the rounded corner will do the grinding and the bevel will be concave. This feature will be appreciated by those who prefer a flat, stout edge for rough work, and a thin, concave edge for fine work. The emery wheels are twelve inches in diameter with four-inch face, and can be used up almost entirely. Extra wheels cost \$7.00 each, net. The tight and loose pulleys are eight inches in diameter, and should run at 800 revolutions per minute. Weight of the 108-inch grinder is 1800 pounds. A perfect water attachment is supplied, the water being delivered in any desired quantity on the bevel of knife by means of a brass centrifugal pump.

**Net Prices Heavy Pattern (Style A) Grinders.**

To grind knives up to 54 inches, complete . . . . .	\$200.00
To grind knives up to 60 inches, complete . . . . .	215.00
To grind knives up to 76 inches, complete . . . . .	235.00
To grind knives up to 84 inches, complete . . . . .	260.00
To grind knives up to 90 inches, complete . . . . .	280.00
To grind knives up to 96 inches, complete . . . . .	310.00
To grind knives up to 108 inches, complete . . . . .	350.00

**CUTTING STICKS.**

	1/2 Inch Square.	3/4 to 1 1/2 Inch Square.	Round for Acme.
30-inch and under, per dozen . . . . .	\$ .75	\$1.50	\$2.50
34-inch and under, per dozen . . . . .	.80	1.60	2.50
38-inch and under, per dozen . . . . .	.85	1.70	2.75
44-inch and under, per dozen . . . . .	.95	1.85	3.00
48-inch and under, per dozen . . . . .	1.00	1.95	3.50
54-inch and under, per dozen . . . . .	1.10	2.10	4.00

**CUTTING STRIPS**

For Hamilton's Patent Cutting Stick, described below.

Under 38 inches, per dozen, net . . . . .	\$ 1.25
38 inches and not exceeding 54 inches, per dozen, net . . . . .	.40

**HAMILTON PATENT CUTTING STICK.**

Consists of a main body piece (A), made to fit the groove of your paper cutter. The body piece has a groove or recess in it, which holds a small strip (B) one-quarter of an inch square. This removable strip is the cutting surface, and is held in place by a steel clamp (C), which is drawn up by the bolts (D). The cutting strips, being square, can be used on four sides, thus giving the same amount of service as the large-size sticks heretofore used.

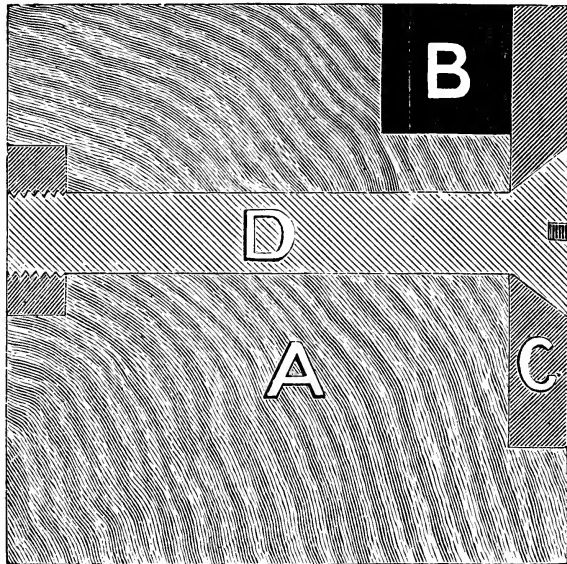

**SEE THAT B ?**

- A is the body piece made to fit groove in cutter.
- B is the cutting strip on which knife strikes. It is one-fourth inch square, and is just as effective as if it was one and one-quarter inch square, also cheaper, and always fits.
- C is steel clamp which holds the cutting strip and prevents warping.
- D is the screw which grips the clamp to the body piece.

**HOW TO ORDER.**

1. Give size square the main body piece is to be. Be particular on this point, and see that groove in cutter is accurately measured. 2. Give length of stick. 3. State how far from front edge of stick the knife strikes. 4. State whether knife cuts from right to left or left to right. In ordering cutting strips give the exact length required. All strips are cut to a standard uniform gauge, and are sure fit.

Main body piece, under 38 inches long, net . . . . .	\$5.00
Main body piece, 38 inches to 54 inches long, net . . . . .	6.00
Main body piece, 55 inches long and over, net . . . . .	7.00
Cutting strips, under 38 inches long, per dozen . . . . .	.25
Cutting strips, 38 inches to 54 inches long, per dozen, net . . . . .	.40
Cutting strips, 55 inches and longer, per dozen, net . . . . .	.50

MONITOR TABLE SHEARS.

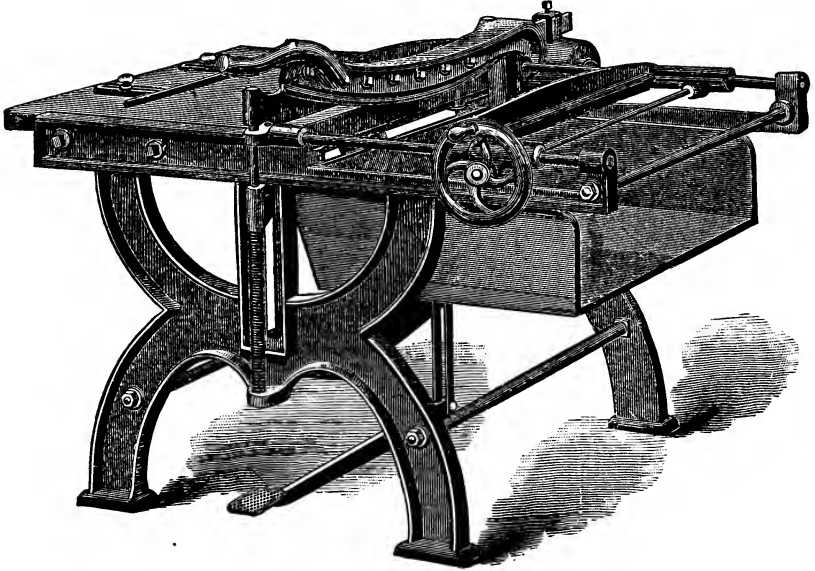

Style of 34-inch Extra Heavy Monitor Table Shears.

Two styles are made : No. 1, 32-inch, for general use, and No. 2, 34-inch, extra heavy, for work that demands greater power. The knife, gauges and method of operation are the same on each style. The knife-bar head is adjustable laterally and vertically, and another adjustment at the head enables the knife bar to be swung either way, so as to secure its perfect alignment with the bed, and insure a perfect shear cut. The screws holding the knife-bar head are  $1\frac{3}{8}$  inches in diameter, and are turned at an angle of 55 degrees, which prevents the knife bar from springing. The clamp is parallel, and descends upon the whole length of sheet at once when the foot is placed on the clamping treadle. The gauge is operated by a hand wheel attached to a geared pinion and rack. The rack is of steel. One revolution of the hand wheel moves gauge four inches. The table is scored both ways, and is provided with side and end adjustable gauges.

- No. 1, all iron, 32 inches . . . . . \$110.00
- No. 2, all iron, 34 inches, extra heavy . . . . . 150.00

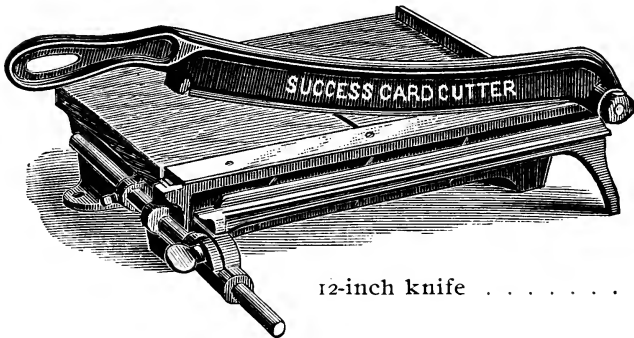

**SUCCESS  
CARD  
CUTTER.**

A well-made, reliable cutter, with movable side and front gauges.

- 12-inch knife . . . . . \$10.00

**BOSTON CARD CUTTERS.**

With Accurate Gauges.

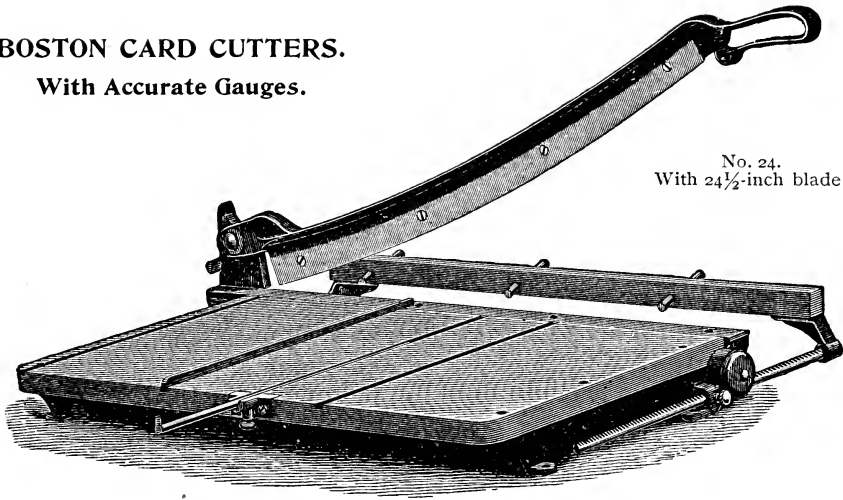

No. 24.  
With 24½-inch blade

These cutters have iron frames and polished hard-wood tables. The Nos. 12 and 24 sizes have accurate front, side and back gauges. The front gauge is operated by racks and pinions which hold the gauge securely at each end, and move it exactly parallel with the knife. No clamp is required, as the knives have a drawing cut, which keeps the sheet straight.

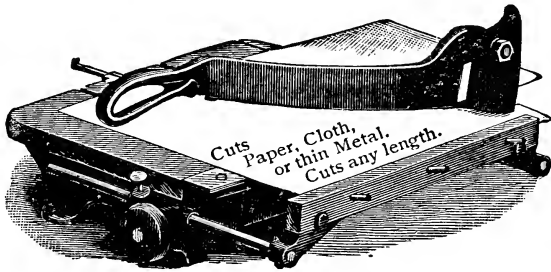

No. 12. With 12½-inch blade.

The No. 12 size will cut any length of sheet in two or more cuts, as the standard that holds the knife bar is on its inner side in line with the cutting edge, as shown in the cut.

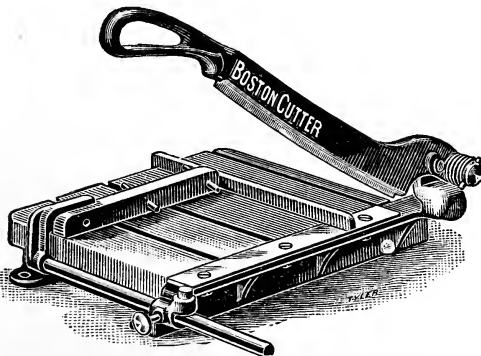

No. 8. With 8½-inch blade.

The No. 8 size has a reversible gauge, which may be used either at front or back.

- No. 8, with 8½-inch blade . . . . . \$8.50
- No. 12, with 12½-inch blade . . . . . 12.00
- No. 24, with 24½-inch blade . . . . . 24.00

**BATES AUTOMATIC NUMBERING MACHINES.**

These very superior machines operate consecutively, duplicate and repeat, and the changes are made instantaneously by simply moving the pointer on the dial. The figures are cut in steel, and print perfectly. The movement of the figures is entirely automatic from 1 to the full numerical capacity of machine. The figures receive ink automatically from a thick felt pad. The mechanism, materials and finish are unsurpassed. All parts are interchangeable, and the operation is noiseless. Weighs about 16 ounces.

A 12345      E 12345  
 G 12345      F 12345

Styles E and G are kept in stock and A and F are furnished to order at short notice.

4-wheels, numbering to	9,999 . . .	\$12.00
5-wheels, numbering to	99,999 . . .	14.00
6-wheels, numbering to	999,999 . . .	16.00
7-wheels, numbering to	9,999,999 . . .	18.00

Prices include ink and pad.



Bates Machine, one-half actual size.

**PARAGON NUMBERING MACHINE.**

A machine of a cheaper grade, but accomplishing the same work as the Bates, the chief difference in method of construction being in the dial-changer. In this machine the changes are made by inserting a pin in the holes opposite the indicators.

4-wheels, numbering to	9,999 . . . . .	\$ 8.00
5-wheels, numbering to	99,999 . . . . .	9.00
6-wheels, numbering to	999,999 . . . . .	10.00
7-wheels, numbering to	9,999,999 . . . . .	12.00

Each machine in wood box, with bottle of ink.

In ordering state style of figures required. Paragon Machines with Gothic figures can be supplied at same prices.

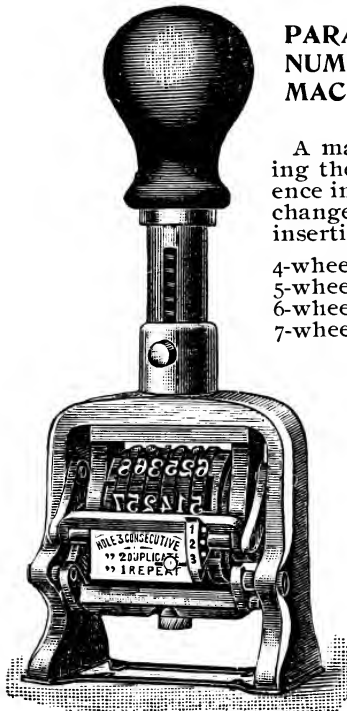

R 1234567890  
 S 1234567890  
 T 1234567890  
 W 1234567890

For Wetter Numbering Machines, see page 849.

**MONITOR PAGING AND NUMBERING MACHINE.**

For Treadle or Steam Power.

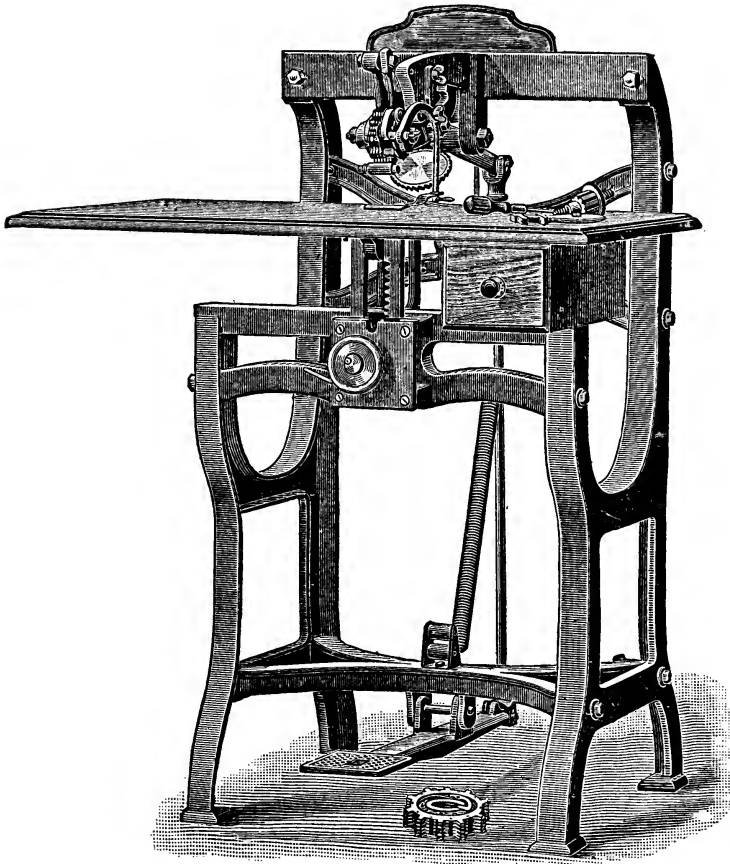

A reliable, well-constructed machine, with steel numbering heads, which by changing a single hand screw will number consecutively or alternately from 2 to 4 to 6, and so on, or from 1 to 3 to 5, and so on, or by the use of a repeating wheel fastened by a single hand screw will repeat a number any desired number of times. The table is adjustable up and down. The foot-power machines are made with journal boxes, so that power fixtures may be added at any time.

	For Power and Treadle.	For Treadle.
With one four-roll steel figure-head . . . . .	\$225.00	\$175.00
With one six-roll steel figure-head . . . . .	235.00	185.00
With one four-roll and one six-roll steel figure-head . . . . .	285.00	235.00

Prices for machines for power include countershaft and hangers. If these are not required, the prices of power machines will be \$30 additional to prices of treadle machines.

**STEEL PAGING AND NUMBERING FIGURE-HEADS.**

Four-roll, to number 10,000, \$50.00	Six-roll, to number 1,000,000, \$70.00
Five-roll, to number 100,000, 60.00	Extra repeater . . . . . 3.00

Prices of numbering heads include one repeater. Styles of figures sent on application.

**ACME  
STAPLE  
BINDERS.**

**The Only  
Staple Binders  
Which Will  
Not Clog.**

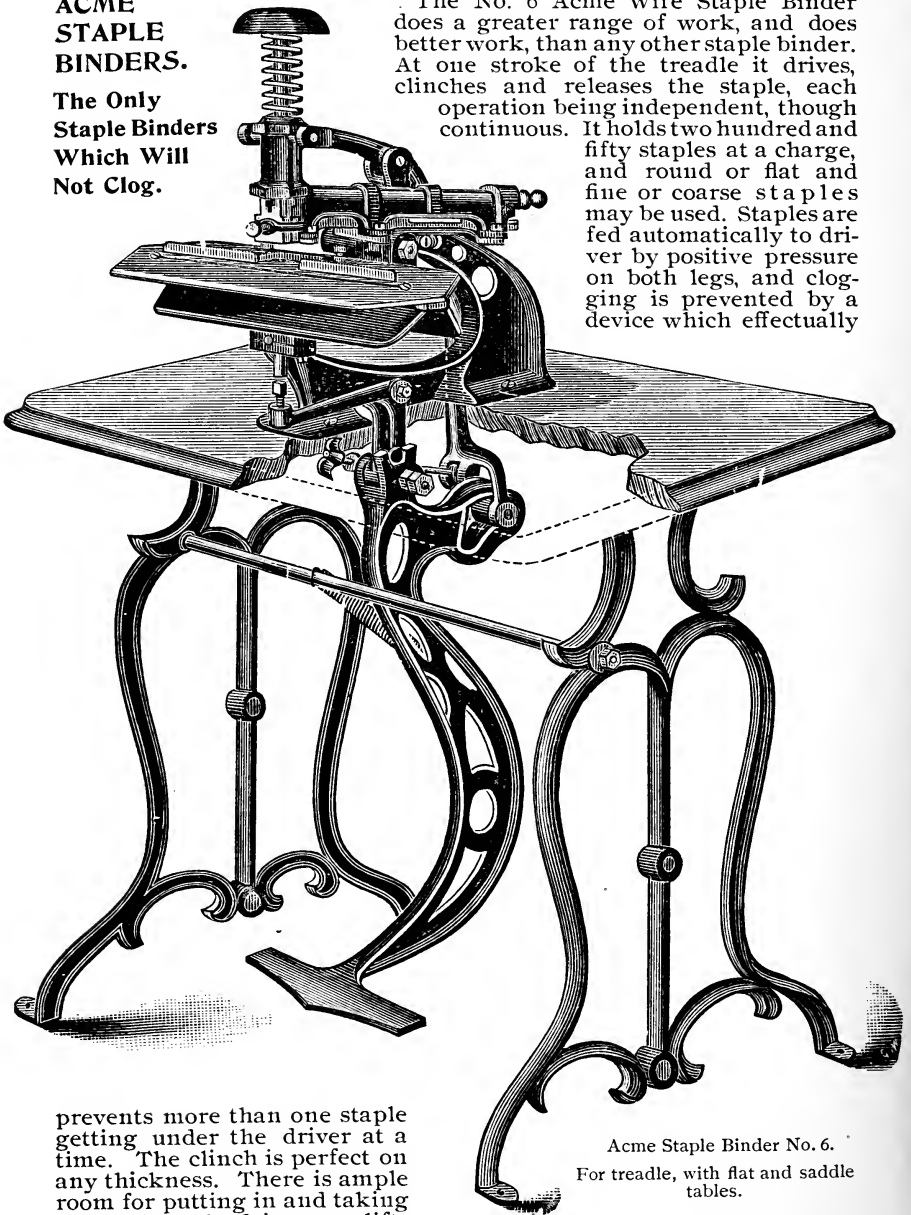

The No. 6 Acme Wire Staple Binder does a greater range of work, and does better work, than any other staple binder. At one stroke of the treadle it drives, clinches and releases the staple, each operation being independent, though continuous. It holds two hundred and fifty staples at a charge, and round or flat and fine or coarse staples may be used. Staples are fed automatically to driver by positive pressure on both legs, and clogging is prevented by a device which effectually

prevents more than one staple getting under the driver at a time. The clinch is perfect on any thickness. There is ample room for putting in and taking out work, as the driver arm lifts more than an inch above the table after each clinch. There is a long space under the arm for calendar work. The treadle has a positive movement. Every machine is furnished with a strong iron stand. Will bind to a thickness of  $\frac{1}{4}$  inch.

The No. 4 Acme is very similar in appearance to the No. 6, and will stitch the same thickness on ordinary paper, but it uses only round fine

Acme Staple Binder No. 6.

For treadle, with flat and saddle tables.



staples, which cannot be used successfully on coated or filled paper unless such work is light. This machine is specially adapted for stapling the average run of pamphlets, calendars, sample work, etc. It does both flat and saddle-back work. It has the device for prevention of clogging, and the clinching is done by the pressure of the blade while driving the staple. Holds two hundred and fifty staples at a charge.

**Prices of Acme Treadle Staple Binders.**

No. 6 Acme Wire Staple Binder, capacity $\frac{1}{4}$ -inch and under, on all paper, for round or flat wire, with table and treadle complete . . . . .	\$40.00
No. 4 Acme Wire Staple Binder, capacity $\frac{1}{4}$ -inch and under, on ordinary paper, for round fine wire only, with table and treadle complete . . . . .	27.00
No. 1, as described and illustrated below . . . . .	6.00

**Staples for Acme Binders.**

For Acme Binder No. 6: No. 21, $\frac{1}{4}$ -inch round; No. 22, $\frac{5}{16}$ -inch round; No. 23, $\frac{1}{4}$ -inch flat; No. 24, $\frac{5}{16}$ -inch flat—per box of 5000 of one size . . . . .	\$1.25
For No. 4: No. 21, $\frac{1}{4}$ -inch round, and No. 22, $\frac{5}{16}$ -inch round—per box of 5000 of one size . . . . .	1.25

**ACME STAPLE BINDER**

**No. 1.**

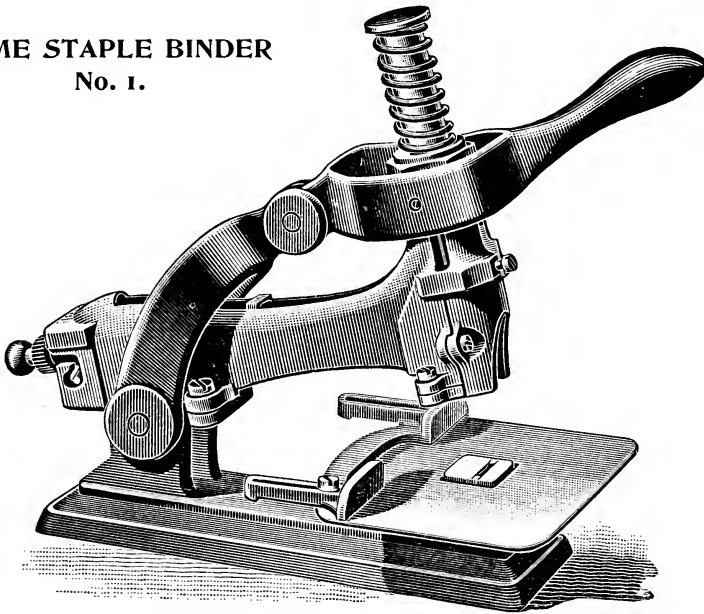

The most satisfactory low-priced staple binder made. *It will not clog*, as only one staple can get under the driver at one time. The frame swings on a pivot, and lifts high enough to give ample room for putting in and taking out the work—an advantage not obtainable on other low-priced staple binders. It holds one hundred staples at a charge. Binds  $\frac{1}{4}$ -inch and under. The staple is fed automatically under the driver, which descends and drives it through the paper, the pressure clinching the staple tight on the under side. Uses flat staples only.

Price . . . . .	\$6.00
Staples: No. 23, $\frac{1}{4}$ -inch, flat; No. 24, $\frac{5}{16}$ -inch, flat—per box of 5000 of one size . . . . .	1.25

**SURE SHOT  
STAPLE BINDER.**

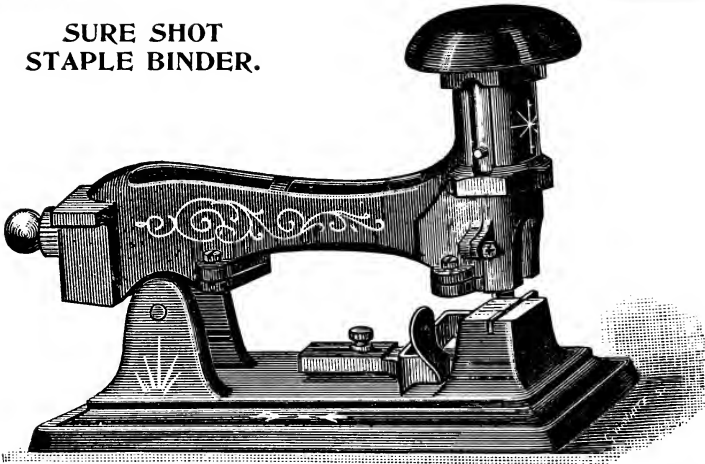

The most reliable binder for office use. Holds one hundred staples at a charge. Works on the same principle as the Acme No. 1, described on page 903, but has no lever. Binds from two to fifty sheets.

Price . . . . . \$3.00  
Staples: No. 23,  $\frac{1}{4}$ -inch; No. 24,  $\frac{5}{16}$ -inch—per box of 5000 of one size 1.25

**BREECH LOADER  
STAPLE BINDER.**

*Only one size of staples in a box.*

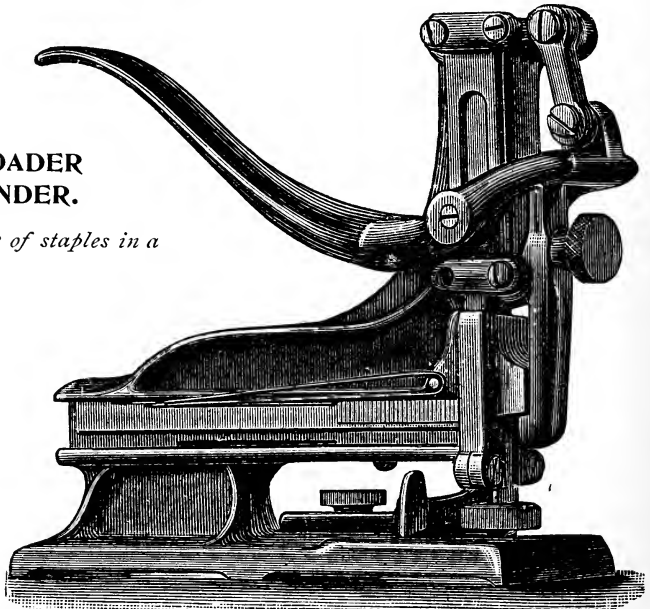

This is a handy machine for office use. Can be put to a great variety of uses. Binds paper or pamphlets from two to fifty sheets with wire staples; holds one hundred staples at a charge, feeds them out automatically, inserts them into the work, and clinches them on the under side.

Price . . . . . \$3.00  
Staples: C,  $\frac{3}{16}$ -inch; D,  $\frac{1}{4}$ -inch; E,  $\frac{5}{16}$ -inch—per box of 1000 . . . . . .50

**HERCULES  
WIRE STAPLE  
BINDER.**

For Hand or Treadle.

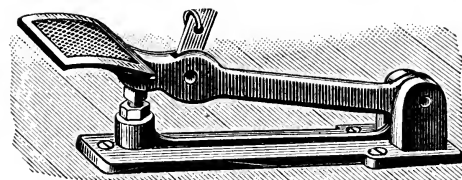

Treadle.

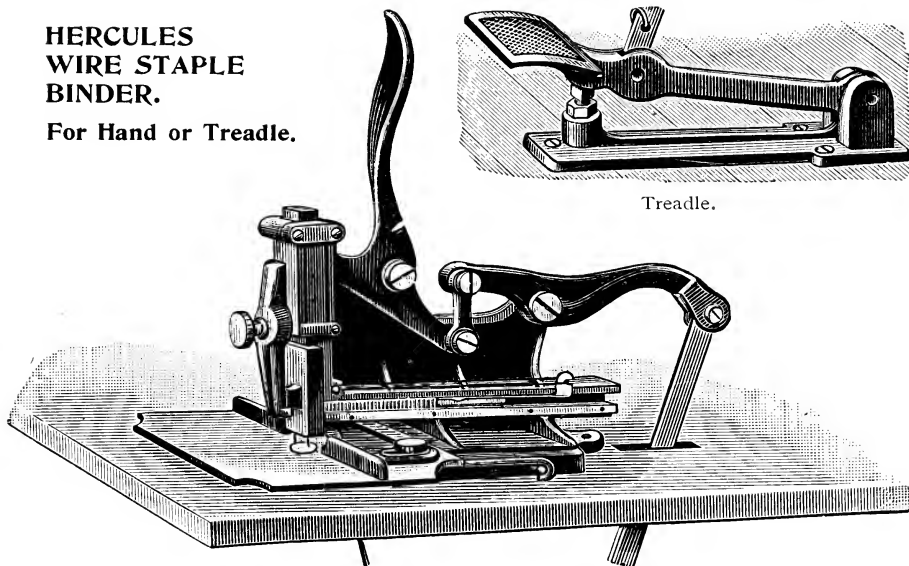

The cheapest treadle staple binder. Binds paper to thickness of  $\frac{1}{4}$ -inch. Staples can be inserted three inches from margin. No table is supplied. The machine is screwed on a bench, and the treadle is screwed to the floor, connecting by means of a rod and spring.

Price, with treadle . . . . . \$10.00  
 Staples: F,  $\frac{3}{16}$ -inch; G,  $\frac{1}{4}$ -inch; H,  $\frac{5}{16}$ -inch; K,  $\frac{3}{8}$ -inch—per box  
 of 5000 of one size . . . . . 1.25

**OTHER STAPLE BINDERS.**

No. 9 Staple Binder binds through paper  $\frac{1}{4}$ -inch thick, complete with table and treadle . . . . . \$36.00  
 No. 8 Saddle Back Staple Binder takes  $\frac{3}{16}$ -inch staples only; designed for saddle-back work, but will take flat work by adding flat table; with saddle back only, \$30.00; with flat and saddle-back tables . . . . . 31.50  
 Lightning Staple Binder No. 1 staples through  $\frac{1}{4}$ -inch paper; No. 2 staples through  $\frac{7}{16}$ -inch paper; each complete with treadle . . . . . 24.00

**WIRE STAPLES.**

The prices for staples for the wire staple binders illustrated on pages 902, 903 and 904 are given under the description of each binder. The following are the prices of staples for the binders not illustrated:

For No. 9 Staple Binder: Staples No. 1  $\frac{1}{2}$ ,  $\frac{3}{16}$ -inch long; No. 2,  $\frac{1}{4}$ -inch long; No. 3,  $\frac{5}{16}$ -inch long—per box of 5000 of one size \$1.25  
 For No. 8 Saddle Back Staple Binder: Staples No. 1,  $\frac{3}{16}$ -inch long, per box of 5000 . . . . . 1.25  
 For Lightning Staple Binder No. 1: Staples No. 7,  $\frac{3}{16}$ -inch long; No. 8,  $\frac{1}{4}$ -inch long; No. 9,  $\frac{5}{16}$ -inch long—per box of 5000 of one size . . . . . 1.25  
 For Lightning Staple Binder No. 2: Staples No. 10,  $\frac{3}{8}$ -inch long; No. 11,  $\frac{7}{16}$ -inch long; No. 12,  $\frac{1}{2}$ -inch long—per box of 5000 of one size . . . . . 1.25

**PERFECTION WIRE STITCHERS.**

Perfection Stitchers, as shown on this and following pages, have for a number of years given invariable satisfaction with a minimum of trouble. They are exceedingly well made and strong. The adjustment from one length of staple to another is accomplished by changing a pin from one hole on dial plate to another.

These stitchers take wire from spools and make staples from round or flat wire of any desired length within the capacity of each machine. There are over 10,000 staples of the length used on an ordinary pamphlet in one pound of No. 25 wire.

**PERFECTION  
"G"  
WIRE STITCHER.**

**Steam Power  
or Treadle.**

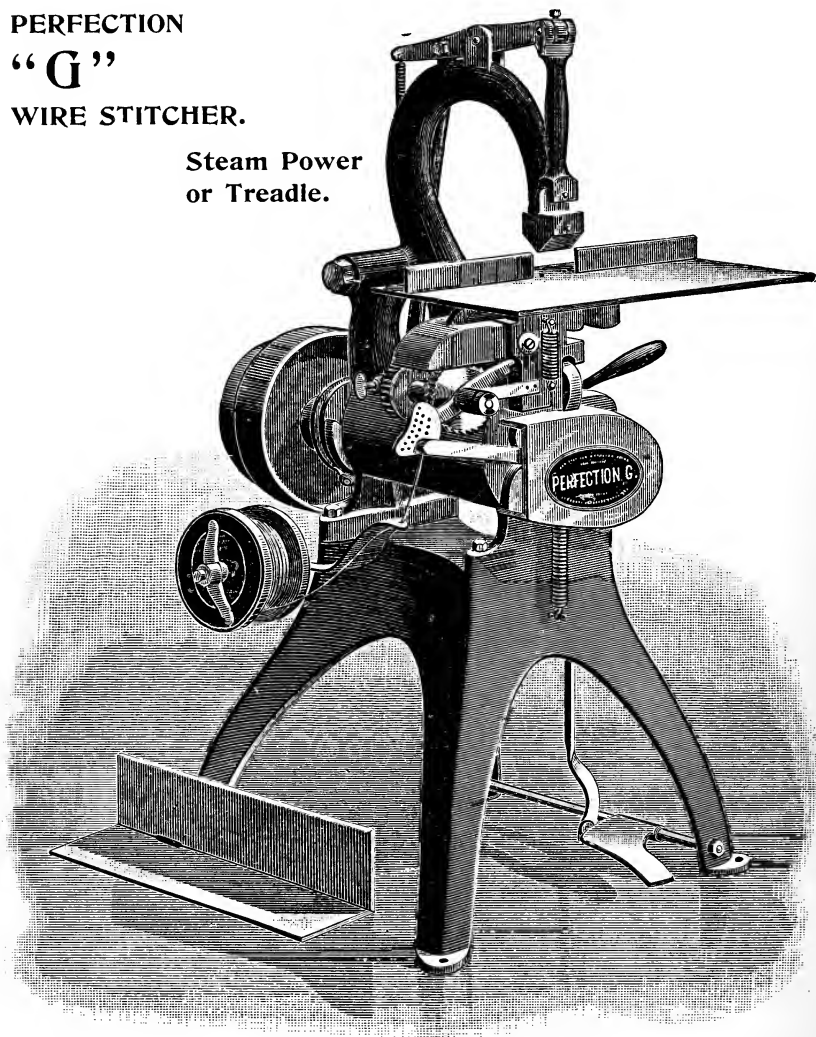

Capacity, two sheets to almost  $\frac{7}{8}$ -inch. Large trough and flat table. Uses 20 to 28 gauge wire.

Perfection "G," for steam or treadle power . . . . . \$250.00

PERFECTION  
"C"  
WIRE STITCHER.

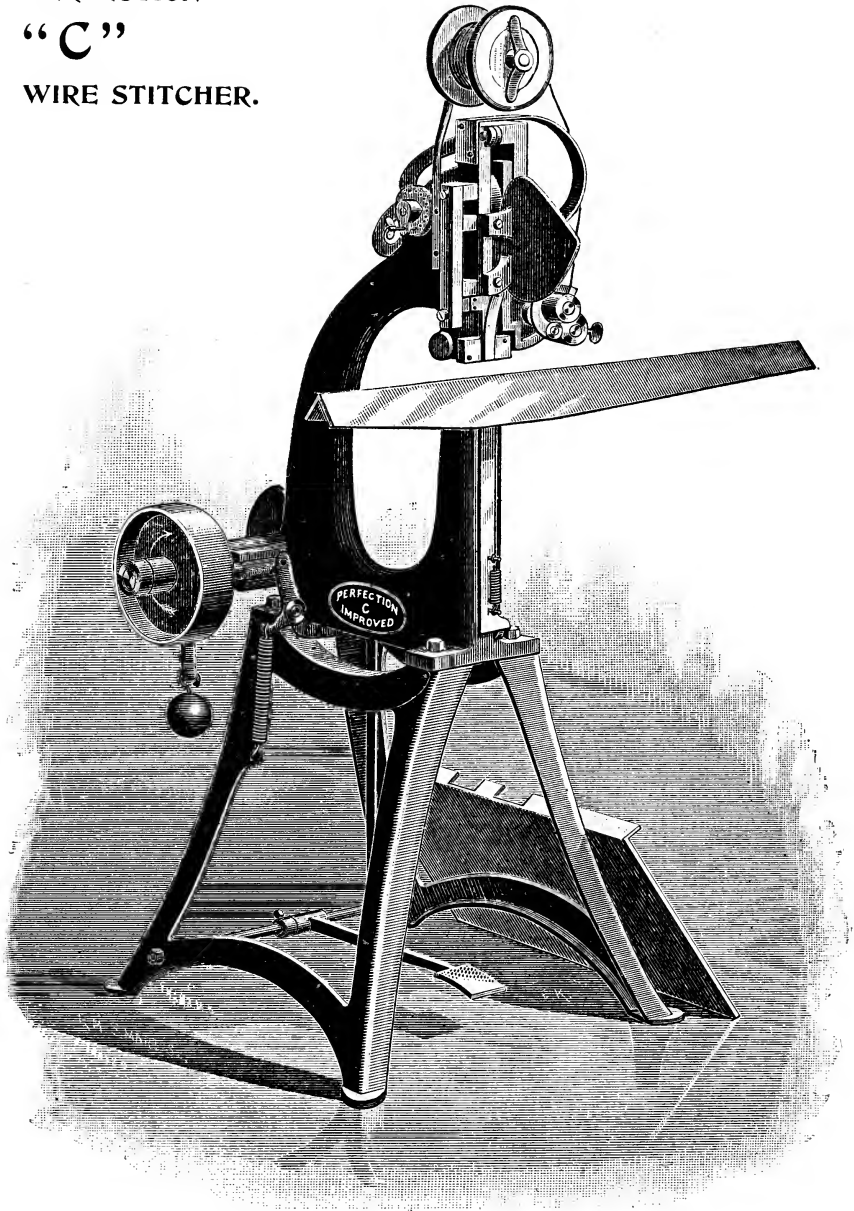

**For Steam Power Only.**

Specially adapted for pamphlet binding, stitching calendars, and all work up to one-fifth inch. Extra long saddle and flat table. Takes 23 to 30 gauge wire.

Perfection "C" Wire Stitcher, for steam power only . . . . . \$150.00

PERFECTION  
"A"  
WIRE STITCHER.

Hand or  
Foot Power.

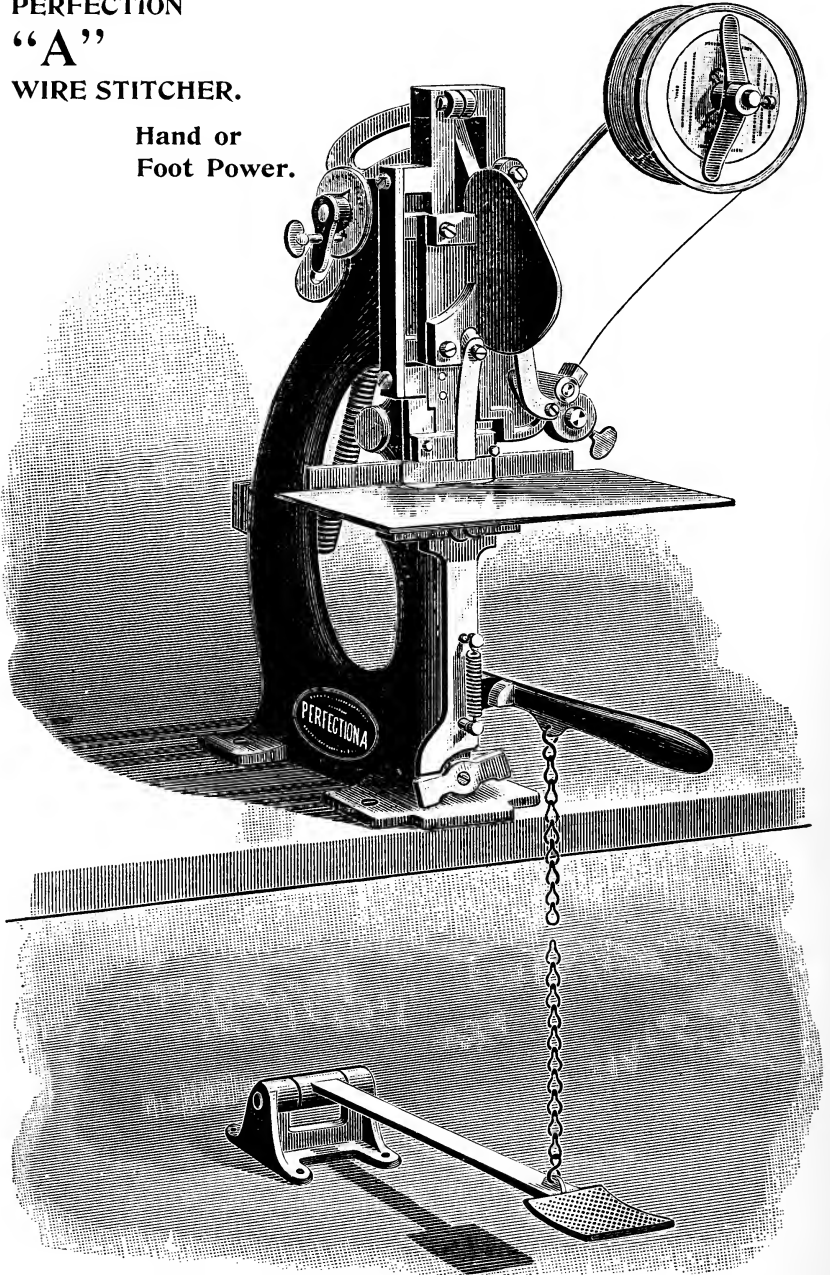

The cheapest satisfactory stitcher of this class now on the market. Is adapted for work varying from two sheets to one-fifth inch in thickness. May be used with flat table or saddle, with wire of from 23 to 30 gauge. The saddle is extra long.

Perfection "A," for hand or foot power . . . . . \$90.00

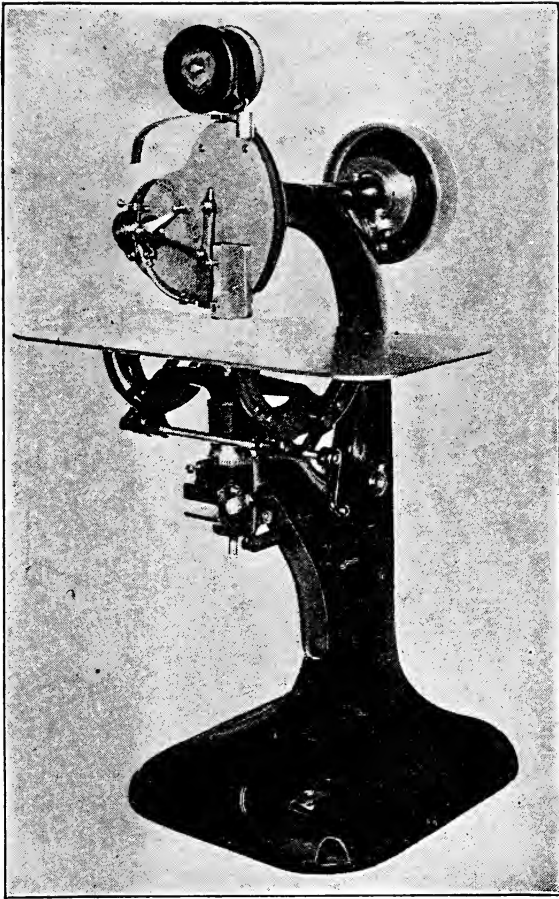

**No. 7 NEW  
PERFECTION  
WIRE STITCHER.**

This machine has all modern improvements. It sets automatically for all thicknesses of work. The patent table is changeable from flat to saddle, or vice-versa, without removal. There is an extra length of space between clinchers and frame to accommodate large calendars and extra large publications. Constructed expressly to stitch heavy work with light wire, without change of parts, although heavy wire can be used if desired. Has the roller-feed device in its latest improved form, and patent supporting and clinching devices which are unexcelled.

Will stitch from one sheet to ¾-inch, and will run wire as fine as No. 25.

Price, complete,  
\$300.00

**PRICE LIST OF WIRE.**

**Subject to Change Without Notice. Discount on Quantities.**

The success of every wire stitching machine depends largely on the quality of the wire used. This wire is the best procurable. A spool holds five pounds of wire. No. 25 is sold per spool at twenty-five cents per pound. Wires Nos. 10 s, 30 s and 60 s, are for Thompson machines only.

Gauges of Wire.		100 Pound Lots.	500 Pound Lots.	1000 Pound Lots.
Round:	Nos. 18 and 19 . . . . . per lb.	\$ .10	\$ .09	\$ .08½
	Nos. 20, 21, 22 . . . . . per lb.	.11	.10	.09
	Nos. 23, 24, 25, or 30 s. . . . . per lb.	.12½	.11	.10
	Nos. 26, 27, 28 . . . . . per lb.	.15	.14	.12½
	No. 30 . . . . . per lb.	.18	.17	.16
Flat:	Nos. 19×21, 19×21½ or 10 s. . . . . per lb.	.16	.15	. . .
	Nos. 20×23 and 20×25 . . . . . per lb.	.17	.16	. . .
	Nos. 21×25 or 60 s. . . . . per lb.	.18	.17	. . .
	Nos. 24×29 . . . . . per lb.	.19	.18	. . .

Spools are ten cents extra each, returnable less transportation charges. A case contains 100 pounds (20 spools).

**MONITOR AUTOMATIC WIRE STITCHER.**

These stitchers do a range of work from two sheets to work  $1\frac{3}{8}$ -inch thick.

**ADJUSTMENTS.**

—There are only two adjustments: 1. The quantity of paper to be stitched is put in the thickness gauge, and the hand wheel at left of gauge is turned until the jaws clamp the paper tight. 2. Turn the hand wheel at right of machine to obtain proper length of staple, then turn the thumb-screw on the feed lever at the left to the same point on the scale.

**WIRE STRAIGHTENER.**

—A patent wire straightener is attached to the combination slide, and by moving the lever in the direction the wire is desired to go it will respond invariably.

**ACCESSIBILITY.**

—All the working parts are in plain view under a glass-faced front. By lifting the glass front you reach the parts. There is a swinging table which is a great convenience for some classes of work, and can be removed instantly if desired.

**WIRE USED.**

—No. 0 uses flat wire,  $19 \times 21\frac{1}{2}$ , only; No. 3 uses

Nos. 25 and 27 round wire, unless specially ordered for flat wire, when it takes Nos.  $20 \times 25$  flat and 25 round; all other Monitor Stitchers use No. 25 round and No.  $20 \times 25$  flat wires.

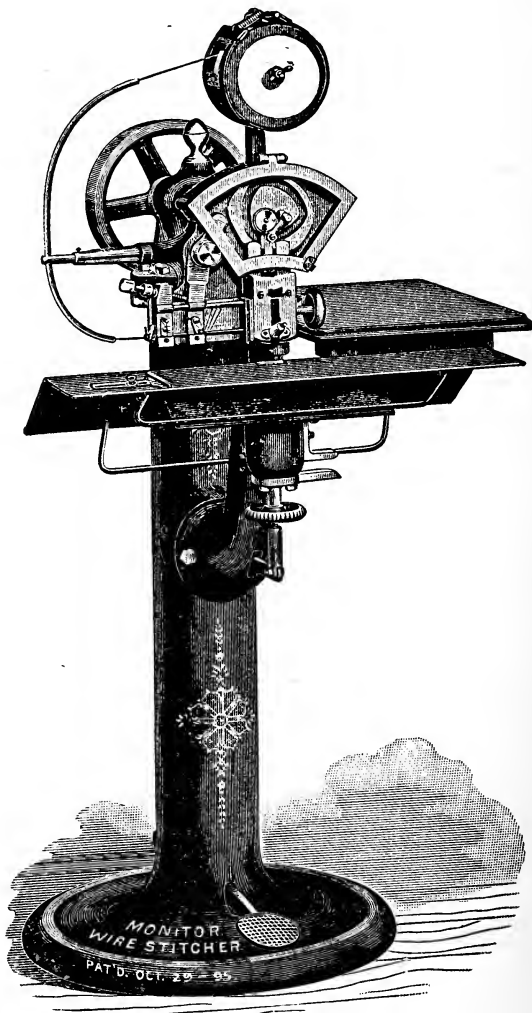

Style of No. 1 Monitor Wire Stitcher.

No. 0, complete, capacity $\frac{1}{4}$ to $1\frac{3}{8}$ inches . . . . .	\$550.00
No. 1, complete, capacity 2 sheets to $\frac{3}{4}$ -inch . . . . .	400.00
No. $1\frac{1}{2}$ , complete, capacity 2 sheets to $\frac{1}{2}$ -inch . . . . .	300.00
No. 2, complete, capacity 2 sheets to $\frac{3}{8}$ -inch . . . . .	200.00
No. 3, complete, capacity 2 sheets to $\frac{1}{4}$ -inch . . . . .	150.00



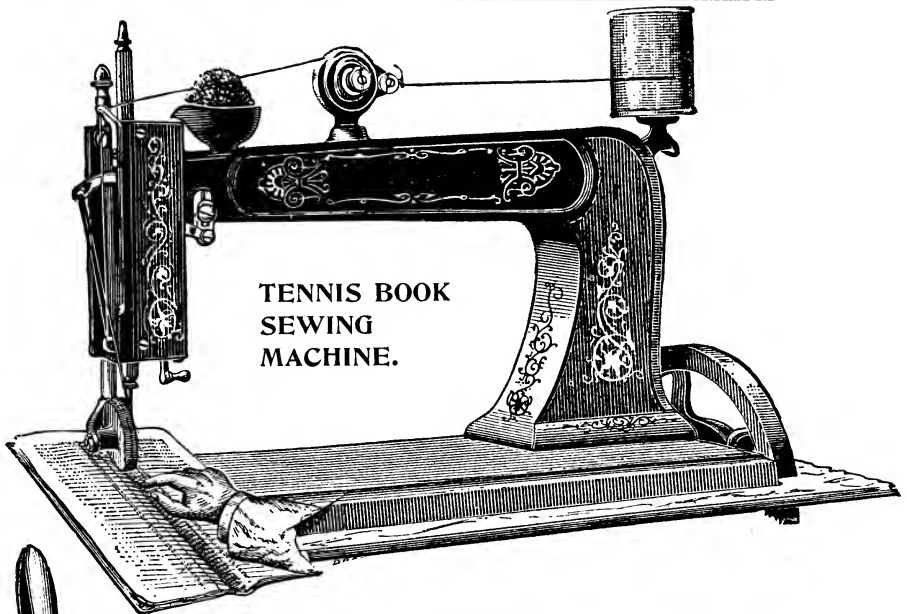

**TENNIS BOOK  
SEWING  
MACHINE.**

Designed for stitching blank books of every kind, and pamphlets and books not exceeding a thickness of  $\frac{3}{8}$  inch. Will sew through back or centre, making stitches one-inch, half-inch or quarter-inch long. Books sewed by this method are durable, and open perfectly. Sample work sent to us will be stitched and returned.

For foot power, with stand and table . . . . . \$60.00  
For steam power, with variable speed, stand and pulleys, complete . . . . . 70.00

Prices are strictly net f. o. b. factory.

**HAND STABBING MACHINE.**

For stabbing pamphlets, receipt books, etc., by hand or foot power. Built of iron, and made to fasten to a bench or table. The position of the needles can be easily and quickly changed, as they move laterally in a slot, and are held by set screws.

For hand power . . \$25.00  
For foot power . . 50.00  
Needles, per dozen 3.00

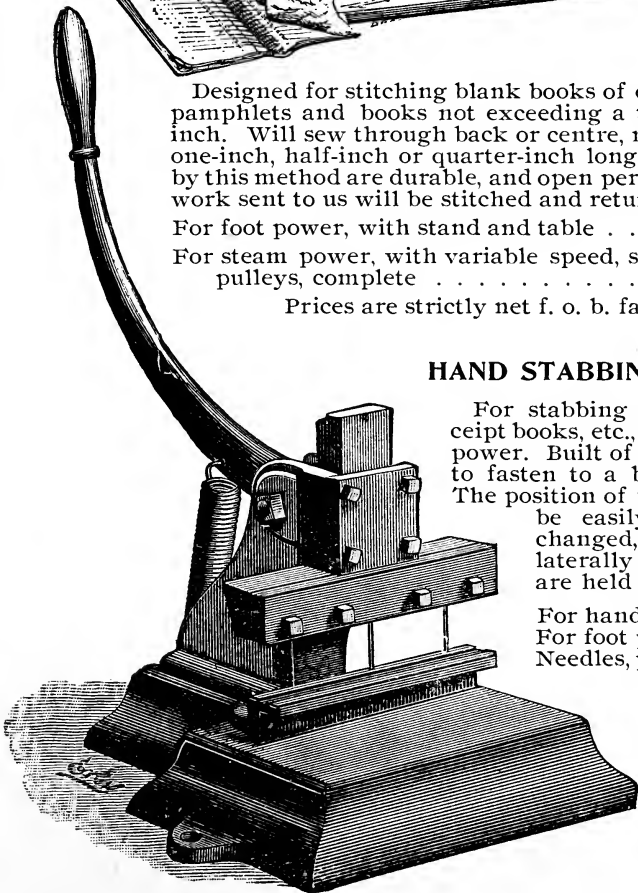

UNION TABLETING APPARATUS.

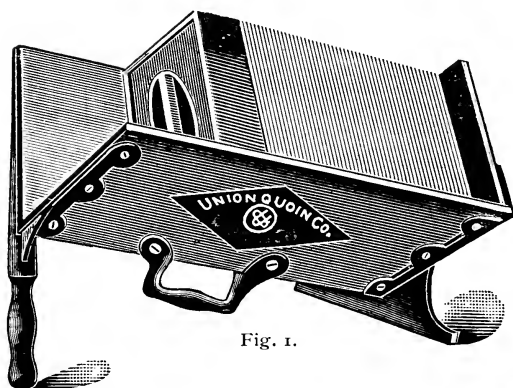

Fig. 1.

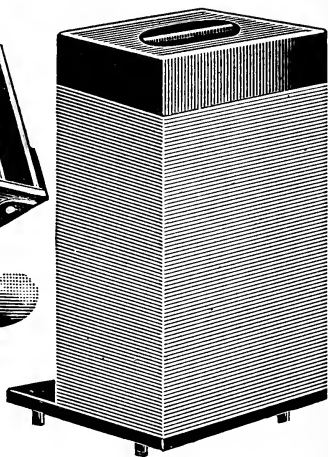
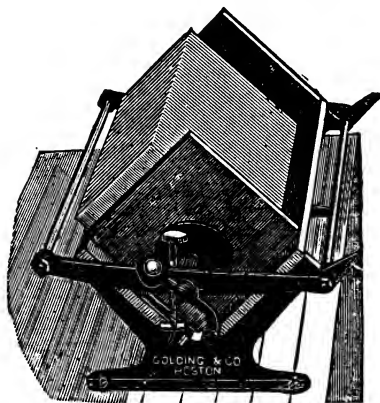

Fig. 2.

In this apparatus paper is held for padding without the use of screws or clamps. The trough (Fig. 1) is V-shaped, and is held at an angle which holds the paper snugly against the sides and the iron base-plate, which forms the bottom of the trough when it is tilted up. The paper in the trough is held under pressure by a heavy iron weight or brick; the trough is tilted up, and is lifted away, leaving the iron base-plate, paper and iron brick as in Fig. 2. The advantage this method has over the tablet presses using clamps is that, by buying extra base-plates and iron bricks an unlimited number of piles of paper may be put up without waiting for the drying of the cement; thus the capacity of this apparatus surpasses that of other apparatus used for a like purpose, and is equally as well adapted for use in both large and small establishments.

Complete, with trough, base-plate and hollow iron brick, size 8½ × 8½ × 18 inches; capacity, 6000 sheets . . . . .	\$7.50
Extra iron bricks, hollow, each . . . . .	2.00
Extra iron bricks, solid, each . . . . .	3.00
Extra iron base-plates, each . . . . .	.75

GOLDING TABLET PRESS.



The paper is put in the V-shaped trough between boards, and, after sufficient pressure has been applied by the screw in the end of a hinged clamping frame, the latter is swung over, exposing the underside of the paper for cementing. Pads from 2 × 2 inches up to full capacity of the press may be blocked. The No. 2 press has a hinged bracket by which it is screwed to a bench, and which permits the paper to be held in a perpendicular position after clamping.

No. 1, will hold 2000 sheets, any size up to 6 × 12 inches . . . . .	\$6.00
No. 2, will hold 5000 sheets, any size up to 8 × 16 inches . . . . .	12.00

**BINGHAM & RUNGE HERCULES ELASTIC PADDING GLUE.**

An elastic, tough, quick-drying preparation, which is applied hot after melting in an ordinary glue pot, and, while entailing more labor, gives better results than the liquid glue. Does not adhere to the edges of sheets as they are removed from the pad, thus preventing tearing of pages in invoice and letter copying books. The color is bright red. Put up in pails, with directions for use on each.

5 pounds in pails . . . . . \$1.50  
10 pounds in pails . . . . . 3.00



**BINGHAM & RUNGE LIQUID PADDING GLUE.**

Made in Red, Purple, Green and Colorless.

The Bingham & Runge Padding Glue was the first put on the market, and it has always maintained its reputation.

The best materials are used in its composition, and on this account it does not get rancid.

A quart will cement about 100,000 sheets of note size.

Half-Pints . . . . . \$ .35  
Pints . . . . . .60  
Quarts . . . . . 1.00  
Gallons . . . . . 3.75

OPEN WITH A COIN OR KNIFE BLADE



**COLORS.** TRADE MARK **PRICES.**  
BRIGHT RED. 1/2 Pint \$ .35  
DARK RED. Pint .60  
Purple. Quart 1.00  
Green. and Colorless. Gallon 3.75

MANUFACTURED BY **BINGHAM & RUNGE,**  
MAUFACTURERS OF  
Printers' Rollers, Composition, Padding Glue  
and the B. & R. Improved Liquid Padding Glue.

**GLUE POT.**



1 quart, each . . . \$ .90  
2 quarts, each . . . 1.20

**LIQUID CEMENT BRUSH.**

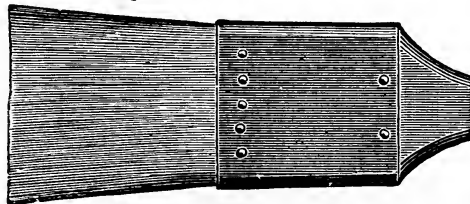

Made of French bristles, flat and double thick.

1 inch . . . \$ .30 | 2 inch . . . \$ .55  
1 1/2 inch . . . .40 | 3 1/2 inch . . . .75

**TABLET KNIFE.**

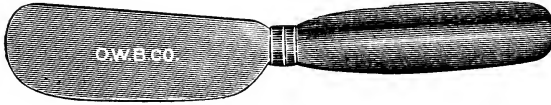

Made specially for separating pads; extra thin and strong.  
Price . . . . . \$ .50

**PAPER COUNTER.**

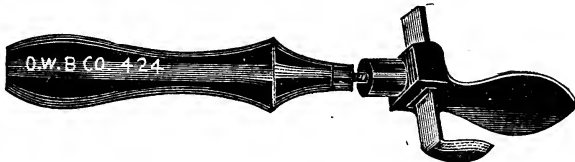

This cut one-fourth actual size.

To make ready for use in pad work, count out number of sheets wanted by hand, on top of which place the plate, then draw the stab up firmly against the paper. The screw in handle holds the stab in place. To operate, place plate on top of lot to be counted and push stab into paper, bearing down at same time.

Price . . . . . \$ .75

**BOOKBINDERS' LETTERING PALLET.**

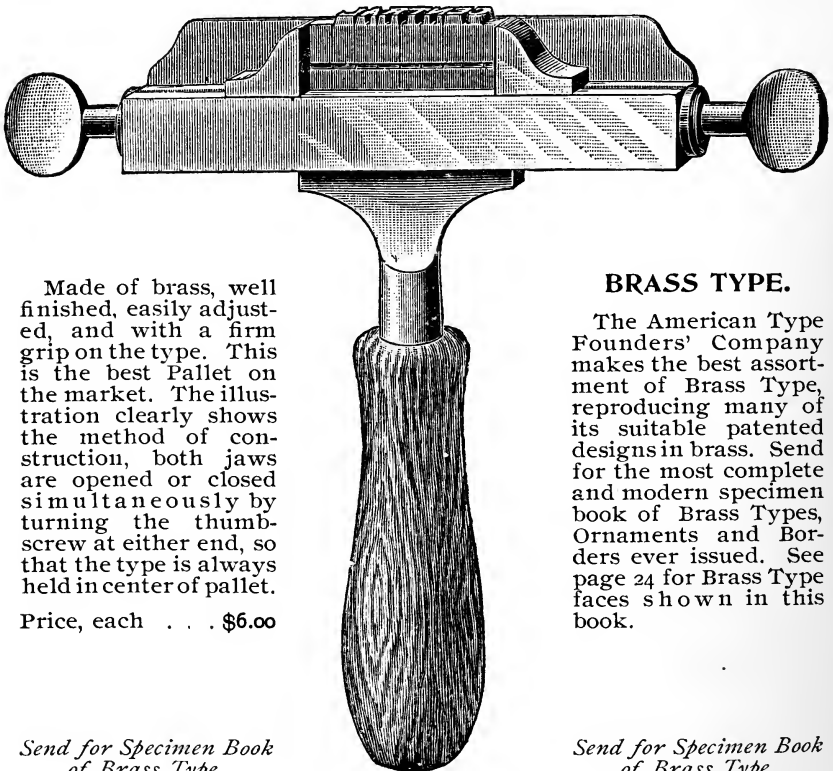

Made of brass, well finished, easily adjusted, and with a firm grip on the type. This is the best Pallet on the market. The illustration clearly shows the method of construction, both jaws are opened or closed simultaneously by turning the thumb-screw at either end, so that the type is always held in center of pallet.

Price, each . . . \$6.00

**BRASS TYPE.**

The American Type Founders' Company makes the best assortment of Brass Type, reproducing many of its suitable patented designs in brass. Send for the most complete and modern specimen book of Brass Types, Ornaments and Borders ever issued. See page 24 for Brass Type faces shown in this book.

*Send for Specimen Book of Brass Type.*

*Send for Specimen Book of Brass Type.*

Nos.

A

B

I

4

7

9

13

17

21

25

29

33

39

46

**No. 4 PUNCHING AND HAND EYELETTING MACHINE.**

**Can be Used for Eyeletting by Hand by Substituting Punches for Eyelet Sets.**

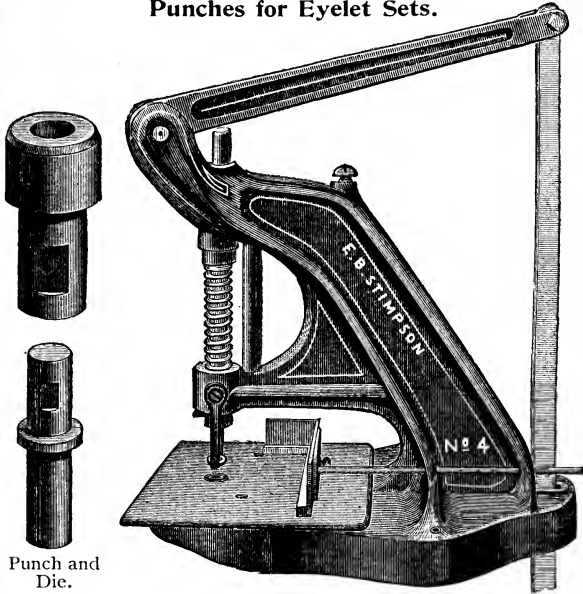

Punch and Die.

This is the proper machine to use with eyeletting machines shown on following pages. Except on cloth, good work cannot be done unless the hole is punched out *clean* before eyeletting. The No. 4 Machine will do work up to  $\frac{3}{8}$ -inch diameter (No. 3 Calendar Eyelet), and has a reach of  $6\frac{1}{2}$  inches back of plunger, and an adjustable gauge for all kinds of work.

By removing the punch and die and substituting an eyelet set, this machine may be used for eyeletting by hand feed, and will do perfect work.

No. 4 Punching Machine, with Treadle, and one Punch and Die . . . . .	\$20.00
Extra Punch and Die, per pair . . . . .	2.50
Eyelet Set, per pair . . . . .	2.50

**COMBINED EYELET PUNCH AND SET.**

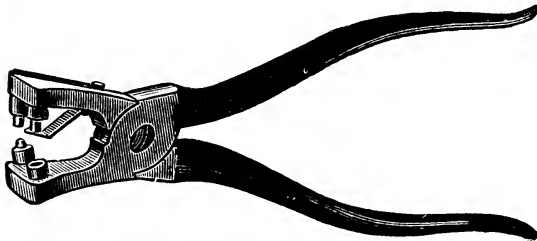

An indispensable tool in the printing office. Punches the hole and sets the eyelet. Takes only one size of eyelet (No. 2 Skirt).

Price, complete . . . . .	\$2.25
Eyelets, per box of 1000 . . . . .	.50

13  
 Sizes of punches and dies corresponding with eyelets made. Order by number.

**SELF-FEED FOOT POWER EYELETTING MACHINES  
With Removable Roadways.**

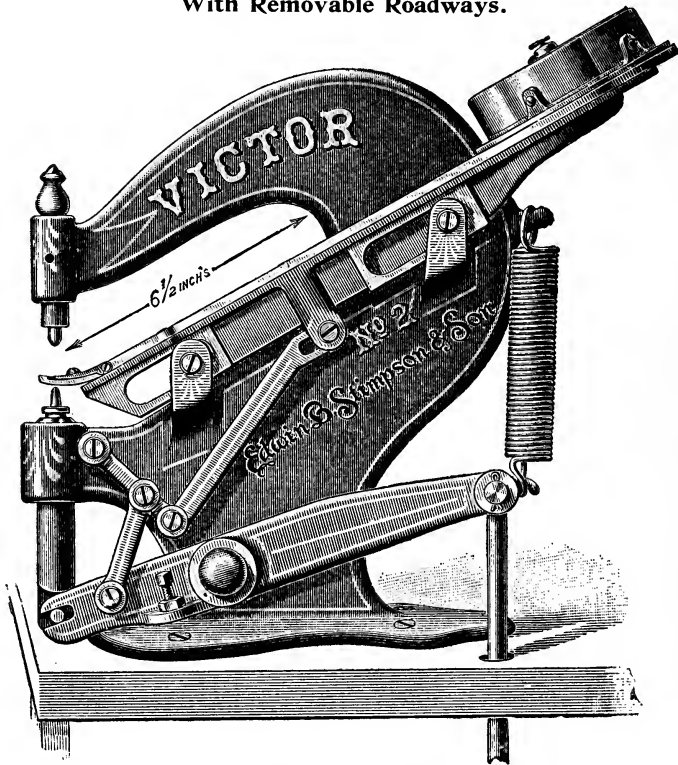

**THE VICTOR**

Has a reach from eyelet set to back of arm of  $6\frac{1}{2}$  inches, and will set an eyelet in the centre of a square of 13 x 13 inches. Will set eyelets in paper, metal, leather, cloth, etc.

The eyelet roadway or feed channel is made to feed but one size eyelet; if other size eyelets are used on machine, an extra roadway is necessary. When ordering machine, specify by name the eyelet for which machine is to be fitted. If extra roadways are wanted, be particular to state the size of eyelet to be used. It takes only a few moments to change one roadway for another on machine.

The Victor is easy to operate, weighs 30 pounds, is 14 inches high, 15 inches deep, and is a perfect working machine and very durable.

No. 2. The Victor, with one roadway . . . . .	\$40.00
Extra roadways, each . . . . .	14.00
Power attachments, extra . . . . .	40.00

In ordering, send samples of eyelets to be used, as the roadway will feed only one size of eyelet. An extra roadway is required for each size of eyelet.

**THE ROYAL**

Differs from the No. 2 Victor in the reach only, which is 9 inches, setting eyelets in a square of 18 x 18 inches.

It weighs 45 pounds, is 15 inches high, 16 inches deep, and is a perfect working and very durable machine.

No. 3. The Royal, with one roadway . . . . .	\$45.00
Extra roadways, each . . . . .	16.00
Power attachments, extra . . . . .	40.00

In ordering, send sample of eyelet to be used, as the roadway will feed only one size of eyelet. An extra roadway is required for each size of eyelet.

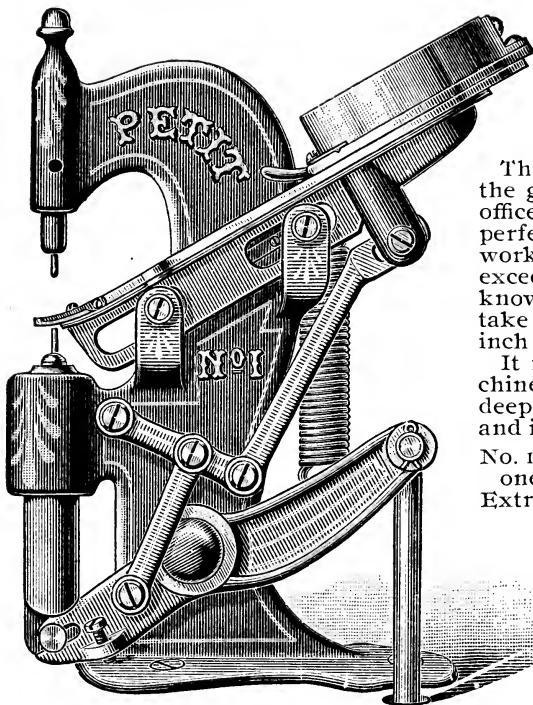

**THE PETIT.**

This is not recommended for the general work of printing offices and binderies, but is perfectly adapted to special work requiring eyelets not exceeding  $\frac{3}{32}$ -inch inside, known as No. 1 "C. Z." It will take the smallest eyelet,  $\frac{1}{16}$ -inch inside, known as "D. E."

It is a perfect feeding machine, 12 inches high, 9 inches deep, weighs only 17 pounds, and is very easy to operate.

No. 1. The Petit, with one Roadway . . . . . \$30.00  
Extra Roadways, each . . . . . 12.00

**EYELETS.**

The largest eyelet used is "No. 3 Calendar," smallest is "D. E.,"  $\frac{1}{16}$ -inch inside. The eyelets

in most common use are "No. 3 Calendar" and "No. 2 Skirt" (as illustrated). The prices of eyelets in large quantities vary from time to time, and special quotations will be given when required.

No. 3 Calendar Eyelets, per box of 5000 . . . . . \$3-75  
No. 2 Skirt Eyelets, per box of 10,000 . . . . . 4-50

Special quotations for larger quantities.

**SIZES OF EYELETS.**

The following cuts show exact size of each eyelet when set in the material eyeletted. Smallest quantity sold 10,000 in one box, except No. 3 Calendar, which is put up in boxes of 5000. They are also packed in bulk cases containing 250,000 of any size.

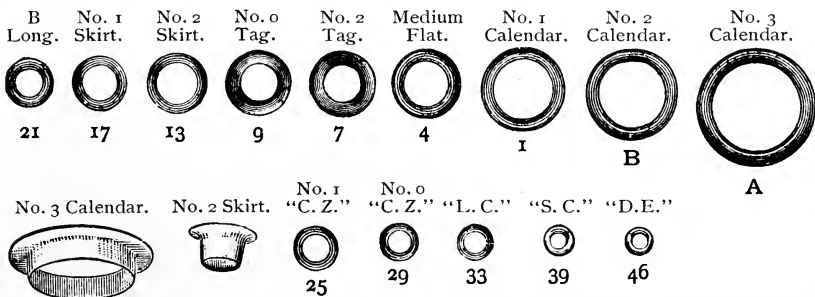

The heavy figures under cuts indicate the size of punch and die to be used with eyelets.

*See page 915 for Punching Machine.*

**HAND EMBOSsing PRESS.**

**For Embossing Monograms, Crests, etc., on Envelopes and Stationery.**

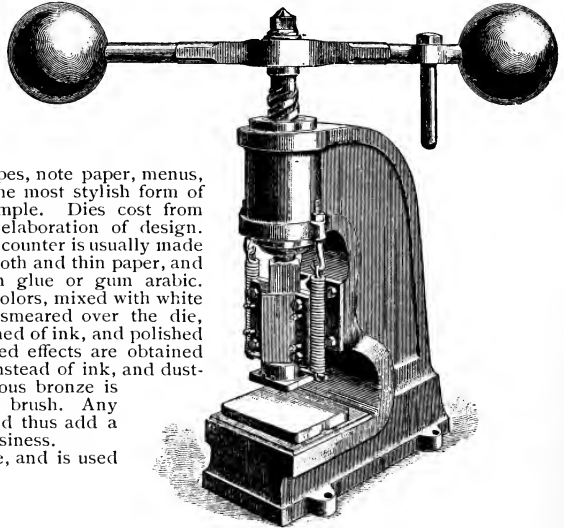

Embossed work on envelopes, note paper, menus, and other fine stationery, is the most stylish form of printing. The process is simple. Dies cost from \$1.00 to \$5.00, according to elaboration of design. Dies are made of steel. The counter is usually made of bristol board, thin rubber cloth and thin paper, and is fastened to bed-plate with glue or gum arabic. The inks are made from dry colors, mixed with white damar varnish. The ink is smeared over the die, and the face of the die is cleaned of ink, and polished by rubbing on paper. Bronzed effects are obtained by embossing with varnish instead of ink, and dusting on the bronze; superfluous bronze is taken off by dusting with a brush. Any printer can do this work, and thus add a lucrative department to the business.

This press is the best made, and is used by all the leading houses.

Large Press, with one Die-Box and Counter . . . . .	\$75.00
Small Press, with one Die-Box and Counter . . . . .	60.00
Extra Die-Boxes, each . . . . .	4.00
Extra Counters, each . . . . .	3.00

Boxing, \$1.50, net.

Those who have use for one press are advised to purchase the large size, as the other will only take small dies. Largest die taken on large press, 5x4 inches; on small press, 4x3 inches.

**FAST GOLD LEAF LETTERING AND STAMPING PRESSES.**

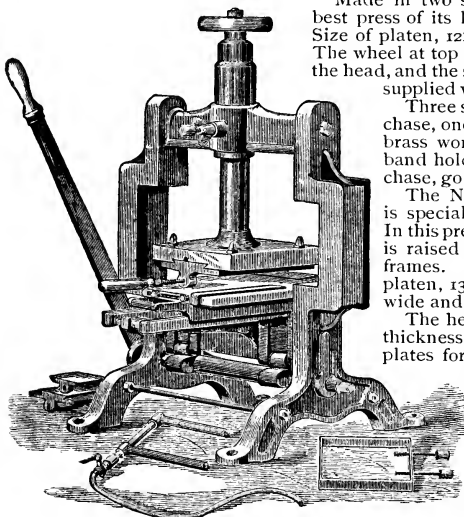

Made in two styles. No. 1, illustrated here, is the best press of its kind for small stamping or embossing. Size of platen, 12x12 inches; size of head, 11x11 inches. The wheel at top carries the screw that raises or lowers the head, and the set screw at front binds it firmly. Can be supplied with 19½ or 26 inches between uprights.

Three stamp-holders, varying sizes; one large chase, one large and small plate for electros and brass work, one atmospheric gas heater, set of band holders, and assortment of steel fillers for chase, go with each machine.

The No. 2 Press, for gas, gasoline or steam, is specially recommended for printing badges. In this press the bed does not slide, and the platen is raised or lowered by screws set in the side frames. Size of head, 12x12 inches; size of platen, 13½x13½ inches. Takes work 14 inches wide and any length.

The head will allow a change of six inches in thickness. One type holder with chase, two plates for electros, one set of fillers, and an atmospheric gas heater, go with each machine. Cheap, accurate and powerful, and indorsed by the users.

No. 1, complete, as described . . . . .	\$150.00
No. 2, complete, as described . . . . .	75.00

No. 1 Stamping and Embossing Press, for steam, gas or gasoline.

Catalogue of Embossing Dies sent on receipt of 25 cents.



**CARVER & SWIFT POWER STAMPING PRESS.**  
Prints and Embosses at One Impression.

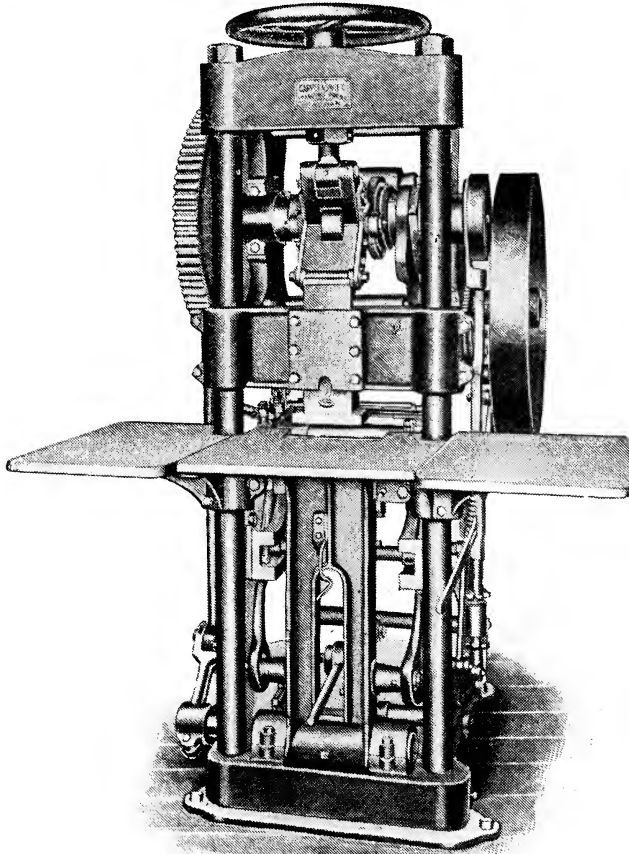

The die is held in a double-jawed chuck on bed of press; immediately over the bed in its vertical position is a counter-block, driven up and down by connection with a powerful toggle. The counter is made in the same way as on the hand-stamping press, as described on opposite page. The ink fountain is at rear of press, having a continuously revolving roller which serves to keep the ink "alive." An oscillating arm carries the distributor, which supplies ink to the die on its backward and forward motion. As the die travels forward, it passes under the wiping plate, around which a web of manilla wiping paper is carried. The contact with the wiping paper removes all ink from the surface of the die, leaving it only in the engraved parts. The bed travels to a vertical position, where it is automatically locked and held for the impression. The sheets are fed to gauge pins as on a job press, and thus at one feeding the most beautiful results are produced.

Perfect register is insured for burnishing bronzed work by the fact that the machine is provided with an automatic lock, which holds the bed in position while the impression is made.

Any properly engraved die from one line, or monogram, up to commercial dies measuring three and one-half inches by eight inches, can be successfully stamped.

The speed is a matter most generally determined by the operator, and while a general average would be about nine thousand impressions per day, the machine has a record of seventeen thousand in less than eleven hours.

The machine weighs about four thousand pounds and occupies a floor space of three feet nine inches by four feet six inches, exclusive of projecting feed boards.

**Stamping press, complete, with countershaft and hangers with friction clutch, wide face pulley and three-step cone pulley, three-step cone pulley for main shaft, two large and two small ink fountains, three counter-blocks, one set each of push and composition rollers, f. o. b. factory . . . . . \$1650.00**

**STIMPSON LEVER AND TREADLE  
ROUND-HOLE PERFORATOR.**

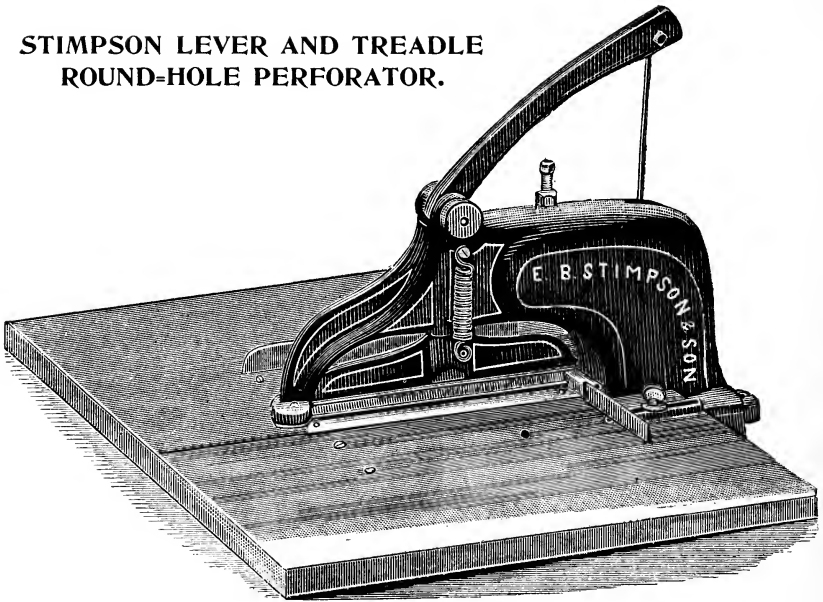

In every respect a perfect and superior machine, in keeping with the reputation of the makers, and well worth the price asked.

Perforates 10 inches, with treadle . . . . . \$40.00

**FRANKLIN  
HAND PERFORATOR.**

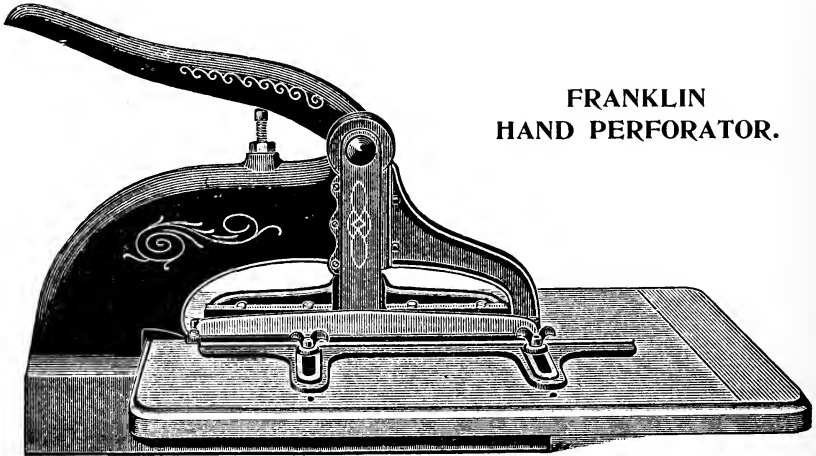

Perforates 10 inches, and is provided with gauges on both sides, so that the sheets may be turned and fed in again, making a continuous perforated line of twenty inches. The pins make round holes, like the perforations on a sheet of postage stamps. Fifteen holes to an inch.

Hand Perforator, 10 inches . . . . . \$25.00

**TREADLE PERFORATORS.**

We list on this page two grades, each of which accomplishes the same work, the difference in prices indicating differences in workmanship and durability.



Standard Grade Treadle Perforator.

Round-hole perforators, with removable pins, with accurate gauges, and the best procurable at the price, meeting the requirements of the average binding and printing office.

Standard Grade, perforates 20 inches, with treadle . . . . .	\$ 75.00
Standard Grade, perforates 24 inches, with treadle . . . . .	100.00
Standard Grade, perforates 28 inches, with treadle . . . . .	125.00
Standard Grade, perforates 24 inches, for power . . . . .	150.00
Standard Grade, perforates 28 inches, for power . . . . .	175.00

**FRANKLIN TREADLE PERFORATOR.**

Mounted on a stand resembling a proof-press stand, with large drawer.

Franklin, perforates 20 inches . . . . .	\$50.00
Franklin, perforates 24 inches . . . . .	60.00
Franklin, perforates 28 inches . . . . .	70.00

STIMPSON ROUND-HOLE PERFORATING MACHINES.

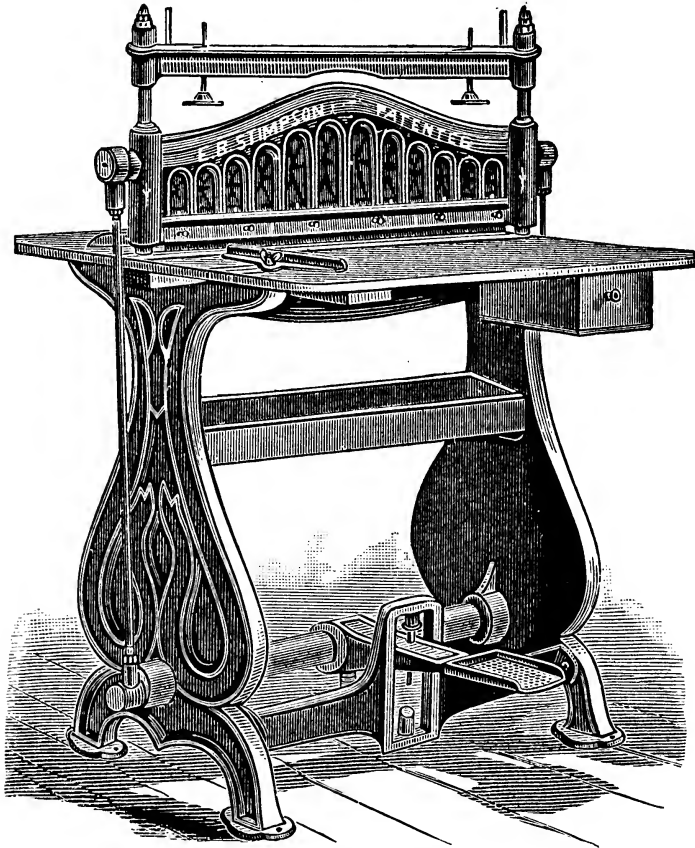

This illustrates the 25, 30 and 36-inch Stimpson Perforators.

This is conceded to be the best line of perforators made in the world. Nothing has been neglected in the way of good material, good workmanship and accurate adjustments, and consequently they do the best work, and wear longer than any other perforators. For those who keep a perforator in constant use an investment in one of these perforators will prove the most profitable, and will be found to keep up a perfect standard of work for many years. Power may be applied to any size.

These perforators are made to make two sizes of perforations—No. 60 gauge (15 holes to an inch), and No. 65 gauge (18 holes to an inch). The No. 65 gauge is the most satisfactory for checks, bonds, drafts, stubs and labels.

No. 60 Gauge.



No. 65 Gauge.



	No. 60 Gauge.	No. 65 Gauge.
20-inch machine, on substantial box-frame iron pedestal .	\$150.00	\$160.00
25-inch machine, as per illustration . . . . .	225.00	240.00
30-inch machine . . . . .	300.00	325.00
36-inch machine . . . . .	400.00	435.00

**Power attachment** for any of these machines, \$125.00 extra.

PEERLESS ROTARY PERFORATORS.

For Power.

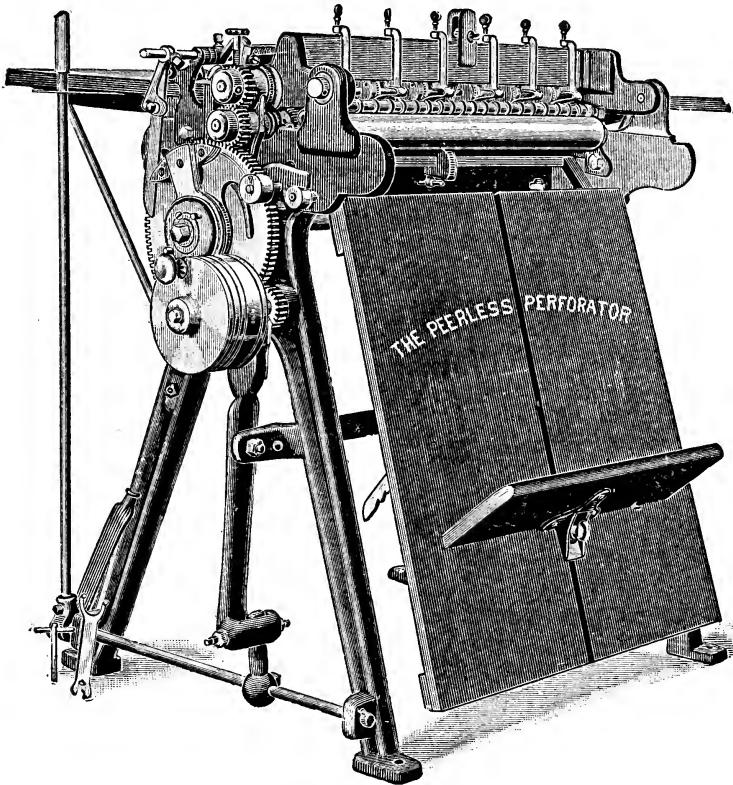

A thoroughly-tested, successful rotary power perforator, cutting six or less separate lines of perforations at a time, and provided with adjustable striking cams for skipping the perforations any distance, from the usual lengths of stubs to very short spaces. When the skip is as short as half an inch special fitting must be done, at a small extra expense. Accurate gauges, easily changed, are provided. The sheets deliver themselves after perforation into a lay-box, taking up very little room, and stacking the sheets regularly. Sheets are fed to machine as into a ruling machine.

Not the least remarkable feature is the form of the perforations, which are *cut out* of the paper cleanly, without any trace of burr, in oblong holes instead of the usual round holes. The machine will perforate a single sheet of manifold paper (without the usual aid of a thicker sheet) or heaviest manilla paper.

The oblong perforations are the distinctive feature of this machine. There is no displacement or swell of the paper along the perforated lines, and the clean cut of every hole, the absence of all burr, and the ease with which the paper separates through the perforations, commend the machine to all who aim to do the best grade of work.

This perforator is in use in a majority of the first-class manufacturing stationers and printing houses, and is built thoroughly well. All parts are interchangeable.

Price, with 6 pairs of cutters and 1 scoring cutter and die, f. o. b.  
Chicago, net . . . . . \$350.00

**STYLE 2-B HICKOK HAND STRIKER RULING MACHINE.**

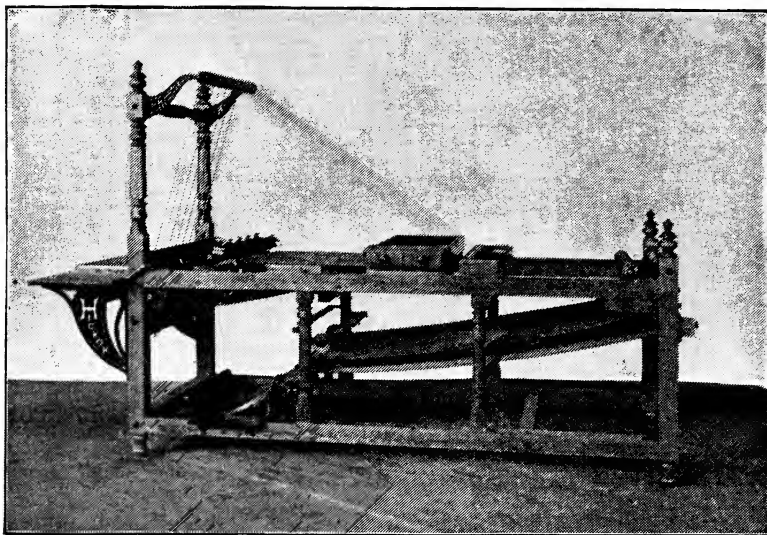

Designed for small shops, where ruling is not done very rapidly, and where, therefore, the ink has time to dry (though the carrier is short) after the paper has passed under the pens and before it drops into the receiving box at feeder's feet. So far as material and workmanship are concerned, there is nothing better made than Style 2-B. The difference between it and the higher-priced rulers is simply in the number of parts used. Striking is accomplished on this machine exactly as it is on the Style 1-A ruling machine. Paper drops into receiving box.

**STYLE 1-A HICKOK HAND STRIKER RULING MACHINE.**

Described on opposite page.

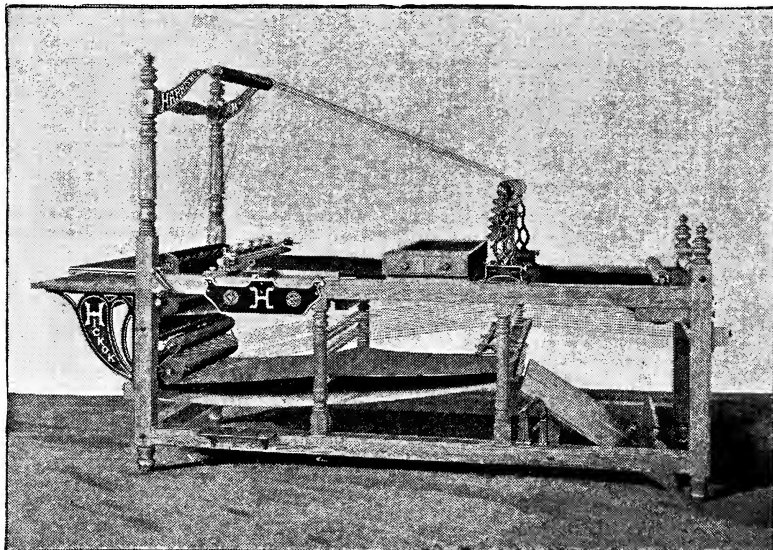

**Style 1-A Ruling Machine** is for use in shops where there is considerable faint or cross ruling, thus economizing the time of automatic strikers used in the same shop. It may also be used in small-sized binderies, where there is not sufficient work for an automatic striker machine. The operator turns the hand crank with the left hand, thus operating the machine by hand, while with the right hand the pen-beam is tilted up and down, doing hand striking. Power may be applied, and steam attachments are furnished to order at an extra charge. Style 1-A is as perfectly built in every part as the most expensive automatic striker ruling machine. The difference in construction is simply leaving off the striker parts and some other necessary pieces required on an automatic striker machine.

**STYLE 1 SINGLE BEAM AUTOMATIC STRIKER RULING MACHINE.**

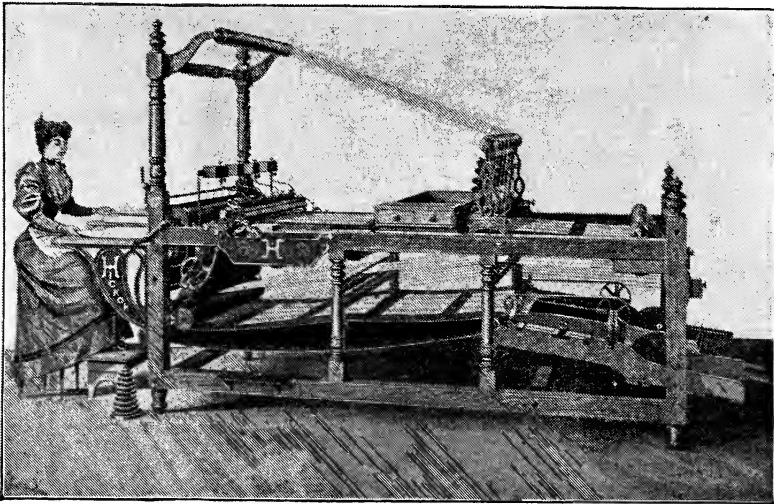

**Style 1** is used for faint or cross-lining when the striker is not operated, and also for down ruling when cross or head lines when the automatic striker is used for the purpose of leaving unruled head spaces by automatically raising the pens from the paper and allowing them again to descend upon the paper, the pens beginning to rule immediately upon touching the paper at a cross head line, and again being automatically raised from the paper and lowered upon the paper again successively at distances prearranged by the positions of the cams, which are adjusted by the operator, who sets them in the circular-revolving cam-head. This machine is for use on all classes of job ruling.

The illustration shows the combined lay-boy and receiver—a device for receiving the paper (after it is ruled) in the lower portion of the machine. Gears are used in setting the striker—friction devices being avoided because gears are more positive in the correct delivery of both speed and power.

**Prices.**

**2-B**, with new Monitor standards, patent beam, patent pen rest, two 32-inch and two 26½-inch clamps, arranged to deliver paper in receiving box at feeder's end of machine (steam fixtures not included—\$15 extra, if required) **\$190.00**

WIDTHS	Between Rails:				
	38 ins.	42 ins.	44 ins.	48 ins.	54 ins.
	32 ins.	36 ins.	38 ins.	42 ins.	48 ins.
<b>Style 1-A</b> , with Imp. Rec'g Box	\$235.00	\$275.00	\$285.00	\$305.00	\$335.00
With Lay-boy and Receiver .	252.00	297.00	307.00	327.00	357.00
<b>Style 1</b> , with Receiving Box .	410.00	450.00	460.00	480.00	510.00
With Lay-boy and Receiver .	427.00	472.00	482.00	502.00	532.00

STANDING PRESSES.

These presses are very strong throughout—in top, base and platen.

No. 2 has four rods, and opens 7 inches between bed and platen.

No. 3 has four rods, and opens 37 inches.

No. 4 has four rods, and opens 37 inches.

The Nos. 5 and 6 sizes, which are illustrated here, have six wrought iron rods,  $1\frac{1}{4}$  inches in diameter. The boxes for main screw are phosphor bronze. The No. 5 opens 46 inches, and No. 6 opens 48 inches. The screw is of  $3\frac{1}{4}$ -inch steel, and is made all in one piece.

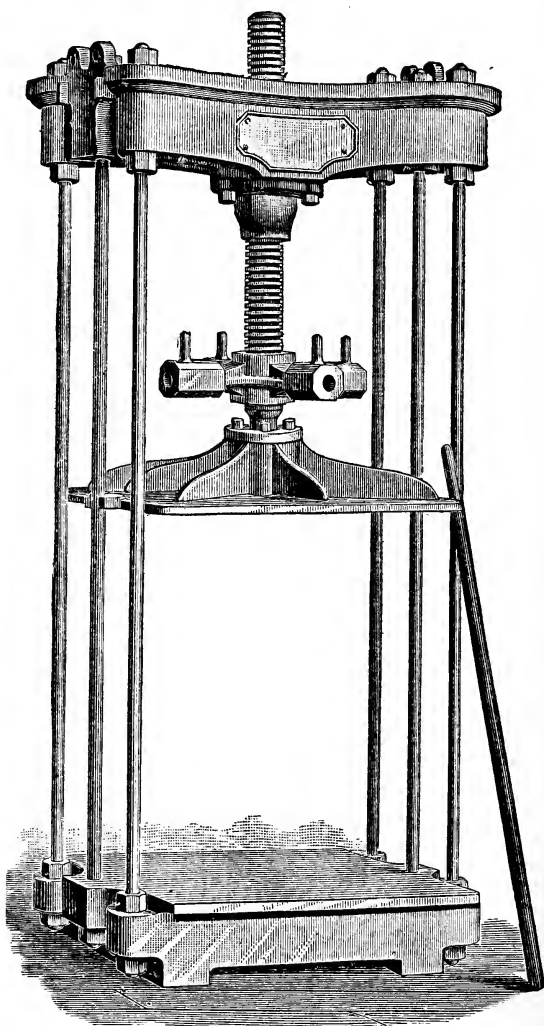

No. 2—Size 10×16, operated by hand wheel at top . . . . .	\$ 25.00
No. 3—Size 16×24, operated by a spider and lever, as shown in cut . . . . .	60.00
No. 4—Size 16×24, operated by hand wheel at top . . . . .	50.00
No. 5—Size 20×28½, operated by a spider and lever, as shown in cut . . . . .	110.00
No. 6—Size 21×29, operated by a spider and lever, as shown in cut . . . . .	130.00

Boxing extra.



**BRASS BOUND PRESS BOARDS.**

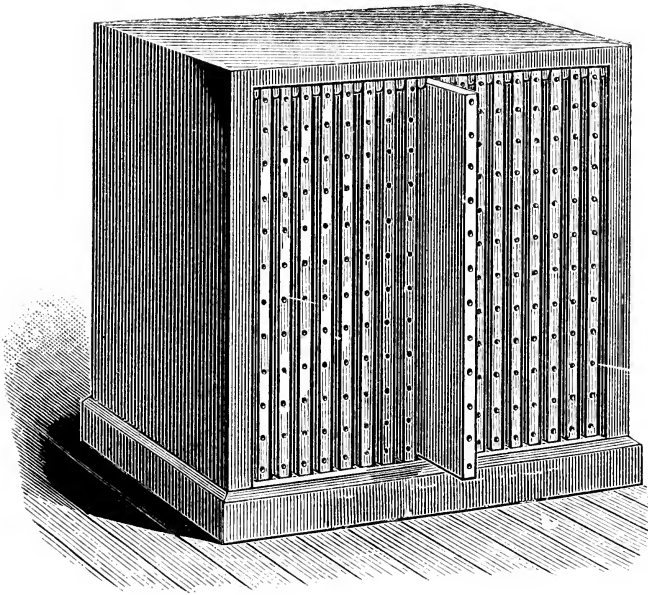

Made of seasoned, kiln-dried cherry, bound with hard brass, with folded corners.

16×24 inches, each . . . . . \$2.75  
 Case to hold 18 boards . . . . . 5.00

Other sizes made to order. Special quotations given on large orders.

**BOOKBINDERS' PRESS BOARDS.**

Made from seasoned cherry, with cleated ends, and all guaranteed first-class, at the following prices, each :

6×10½ inches . . . . .	\$ .20	15×20 inches . . . . .	\$ .80
8×10½ inches . . . . .	.25	16×24 inches . . . . .	.95
8×12 inches . . . . .	.30	20×24 inches . . . . .	1.05
10×13 inches . . . . .	.35	22×28 inches . . . . .	1.30
11×14 inches . . . . .	.45	24×30 inches . . . . .	1.35
10×16 inches . . . . .	.55	24×32 inches . . . . .	1.45
12×16 inches . . . . .	.60	26×40 inches . . . . .	2.80
12×18 inches . . . . .	.70	30×36 inches . . . . .	3.25
13×20 inches . . . . .	.75	36×44 inches . . . . .	4.50

Other sizes made to order at proportionate prices. Special quotations given on large orders.

**CUTTING BOARDS.**

8×12 inches, diagonal grain, per pair . . . . .	\$1.75
8×12 inches, straight grain, per pair . . . . .	1.20
Larger sizes, straight grain, per square foot . . . . .	.90
Larger sizes, diagonal grain, per square foot . . . . .	1.25
End-wood cutting boards, iron bound or screw clamped, per square inch, face measure . . . . .	.02½

## FOR MAILING DEPARTMENT.

### THE HORTON MAILER.

Patented May 11, 1894.

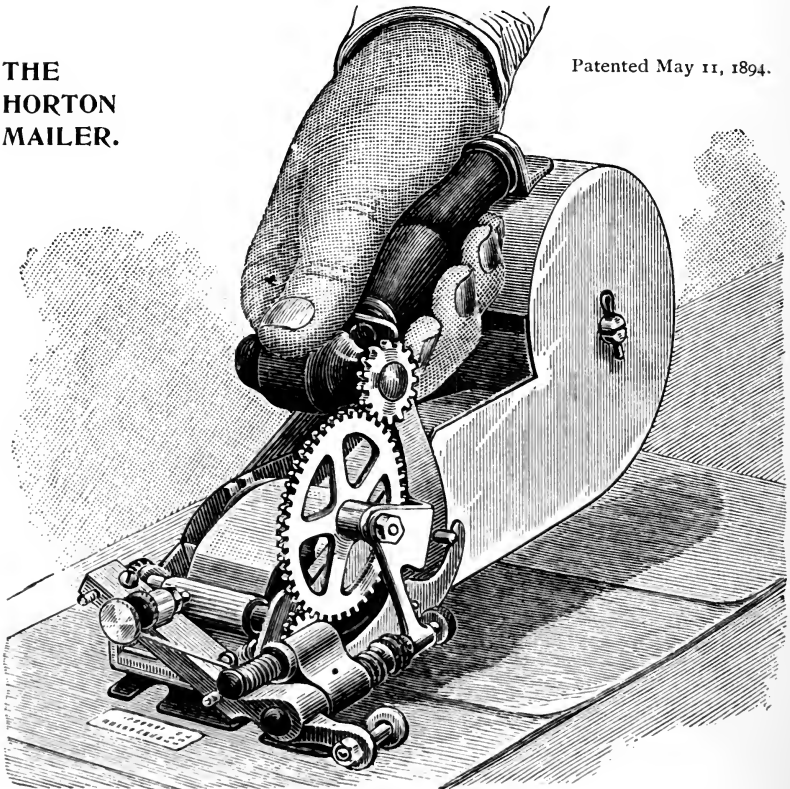

This is the best label-pasting mailer. It is quicker and more exact, because all its movements are positive. It is so simple that it can be worked rapidly and efficiently by the inexpert, while experts have addressed with it at the rate of 170 per minute. It is operated, as illustrated above, by one hand, leaving the other entirely free to manipulate the papers or wrappers.

It guides and thoroughly pastes the slip, scrapes off all surplus paste, and sticks the label cleanly and firmly. The knives are thin and adjustable, with two cutting surfaces, and can be easily sharpened. The arrangements for adjusting knives with each other and regulating tension of knives are very exact.

It is very strongly made, and is the most durable of mailers.

*The Ladies' Home Journal*, Philadelphia, circulation 275,000: "The Horton Mailer cuts and pastes the slip on the *Journal* or wrapper more thoroughly than the machines we have been using. . . . We do not believe it has an equal on the market to-day."

Price, with extra knives, paste strainer, screw driver and oiler,  
net . . . . . \$20.00

The exact size is 12 inches long by 3 inches wide by 5 inches high, and the weight is 2¾ pounds.

EVERYTHING FOR THE PRINTER

**RUKENBROD MAILER.**

**New Style—All Metal.  
With Bell Attachment.**

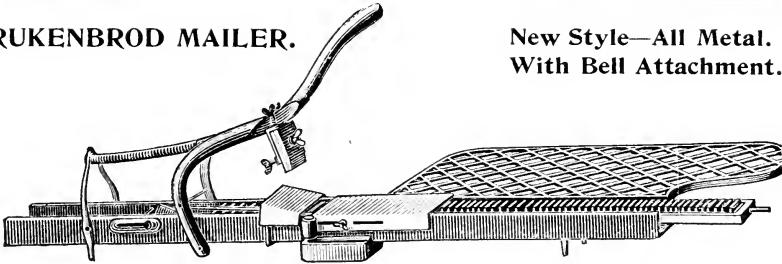

This mailer prints direct on the paper or envelope, clearly, and as rapidly as paper can be put under the platen. It is the best mailer of its class. Each address is brought under the platen automatically, and bell quads may be used which will ring an alarm bell when the papers for any town are all addressed, whereupon the next town wrapper address is printed. Each mailer is provided with two platens, one for two-line address and one for three- and four-line addresses. No other mailer of its class will print a four-line address.

All metal mailer (as per illustration), net . . . . . \$12.50

**RUKENBROD MAILING GALLEY.**

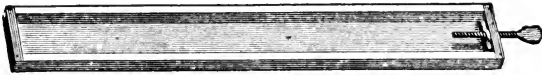

Wood rim, zinc bottom . . . \$ .60	Galley reglet, per hundred . \$ .30
Wood rim, brass bottom . . . .85	Bell quadrats, per hundred . 1.00

**MUSTANG MAILER.**

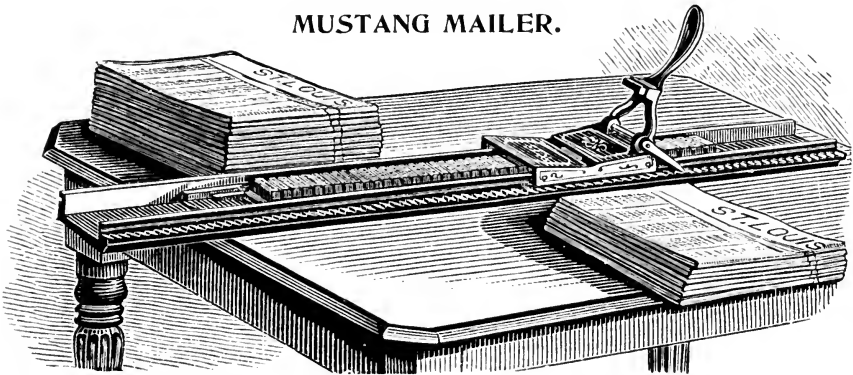

This mailer prints directly on the paper or envelope. The platen and its frame moves automatically, printing one address at a time. It will print three-line (8 Point) addresses.

The Mustang Mailer occupies a space 37 inches in length and 4½ inches in width, and is made wholly of iron without springs or complications of any kind. Speed is regulated solely by the speed of operator in passing the papers to and from the mailer.

The mail list is made up in galleys ten ems Pica wide on the inside. Each galley holds seventy-five addresses. The weight of the machine is fifteen pounds, and of the galleys one pound.

Price . . . . . \$10.00

**MUSTANG MAILING GALLEY.**



Zinc bottom . . . . . \$ .50	Brass bottom . . . . . \$ .75
------------------------------	-------------------------------

THE ACME MAILER.

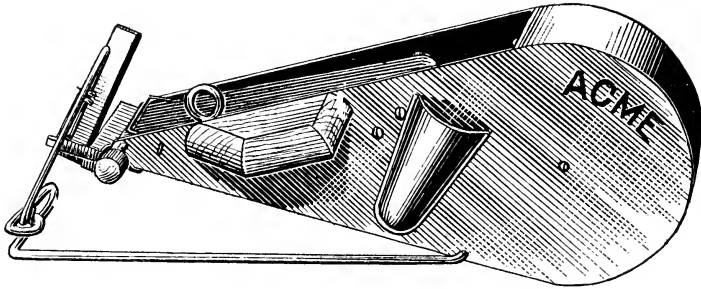

A good low-priced mailer, of which a great many are in use. It is built on the same lines as most of highest priced mailers.

Price, net . . . . . \$15.00

**ECONOMY WRAPPER PASTER.**

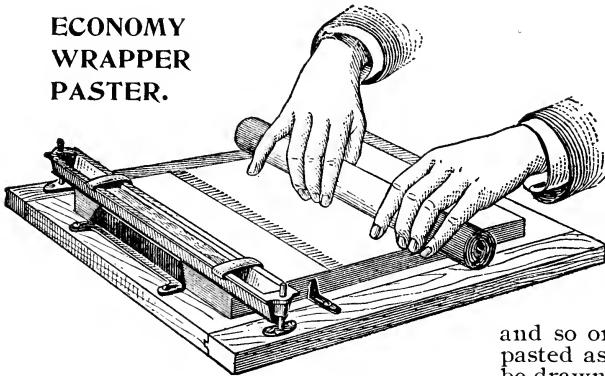

Patent applied for.

The paste fountain has a perforated bottom through which the paste reaches the top sheet of a pile, which may contain four hundred sheets. As the top sheet is drawn off, the next is pasted automatically and instantly,

and so on. Wrappers are pasted as fast as they can be drawn from the pile.

It saves all the time of "laying out" and applying paste with a brush, fifty per cent. in paste, and a great deal of space, as three or four hundred wrappers occupy no more table room than one, and you can wrap on top of the pile, as indicated in the cut.

- No. 10. For width of 10 inches or less, each . . . . . \$4.00
- No. 14. For width of 14 inches or less, each . . . . . 4.50
- No. 16. For width of 16 inches or less, each . . . . . 5.00

**NEWSPAPER PASTER.**

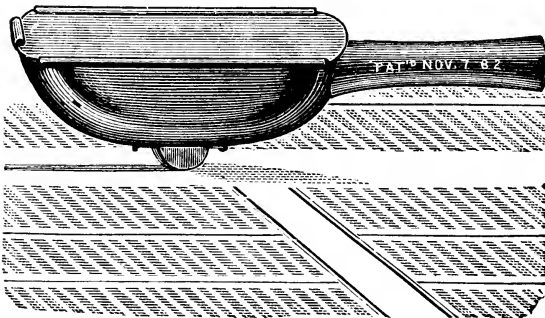

This is a tight brass box, with a handle, in which paste is put. In the bottom of the box a revolving wheel is placed which carries the paste out in a thin line to the sheet to be pasted. This wheel can be regulated to give a fine or coarse feed, as required.

The paster is carried in the hand between the thumb or forefinger while the sheets are being folded.

Price, complete, including two wheels and two gates . . . . . \$3.50

## MISCELLANEOUS SUPPLIES.

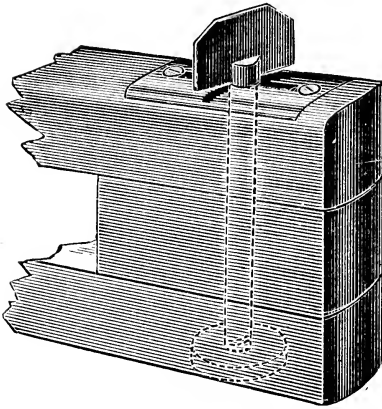

Fastening, closed.

### HAMILTON NEWSPAPER FILE.

Made of cherry, finished in oil, with brass fastenings and polished steel thumb-screws. The method of opening and closing this file is novel and simple. The clasp end of file has a flat-headed thumb-screw (see cut), which is passed through a slot, and by giving the screw a quarter turn the file is securely locked. When the head is turned parallel with the file it opens instantly.

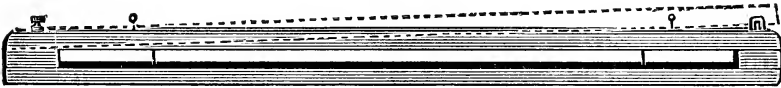

Price, each . . . . . \$1.25

The following sizes are made :

- |                               |                               |
|-------------------------------|-------------------------------|
| To hold sheet 20 inches long. | To hold sheet 28 inches long. |
| To hold sheet 22 inches long. | To hold sheet 30 inches long. |
| To hold sheet 24 inches long. | To hold sheet 34 inches long. |
| To hold sheet 26 inches long. | Other sizes to order.         |

### HOLLY-FACE TINT BLOCKS.

Most useful for the rapid setting up of tint forms. These blocks have a beautiful, perfect, smooth surface, and print solidly.

1-line wide, per foot . . . . . \$ .10	10-line wide, per foot . . . . . \$ .48
2-line wide, per foot . . . . . .12	12-line wide, per foot . . . . . .50
3-line wide, per foot . . . . . .15	15-line wide, per foot . . . . . .66
4-line wide, per foot . . . . . .20	18-line wide, per foot . . . . . .75
5-line wide, per foot . . . . . .22	20-line wide, per foot . . . . . .80
6-line wide, per foot . . . . . .24	24-line wide, per foot . . . . . .85
8-line wide, per foot . . . . . .36	

Larger pieces squared up, any size desired, at 1 cent per square inch.

### LABOR-SAVING TINT BLOCKS.

These consist of strips of engraver's maple, with polished face, cut to even Picas and Nonpareils in width. A font consists of two pieces each 1, 1½, 2, 2½, 3, 3½, 4, 5, 6 and 8 ems Pica wide, all 8 inches long. All the printer has to do to make a tint is to set his panel to even Picas, select a tint strip of same width, and cut it the desired length.

Price, per font . . . . . \$1.00

**THE SURGUY NEW HOT AIR STEREOTYPING APPARATUS.**

The furnace and casting box are combined. One fire of coal, wood or gas will melt metal and dry matrix simultaneously or separately if preferred, as metal pot is detachable. Each apparatus will make thin or type-high plates.

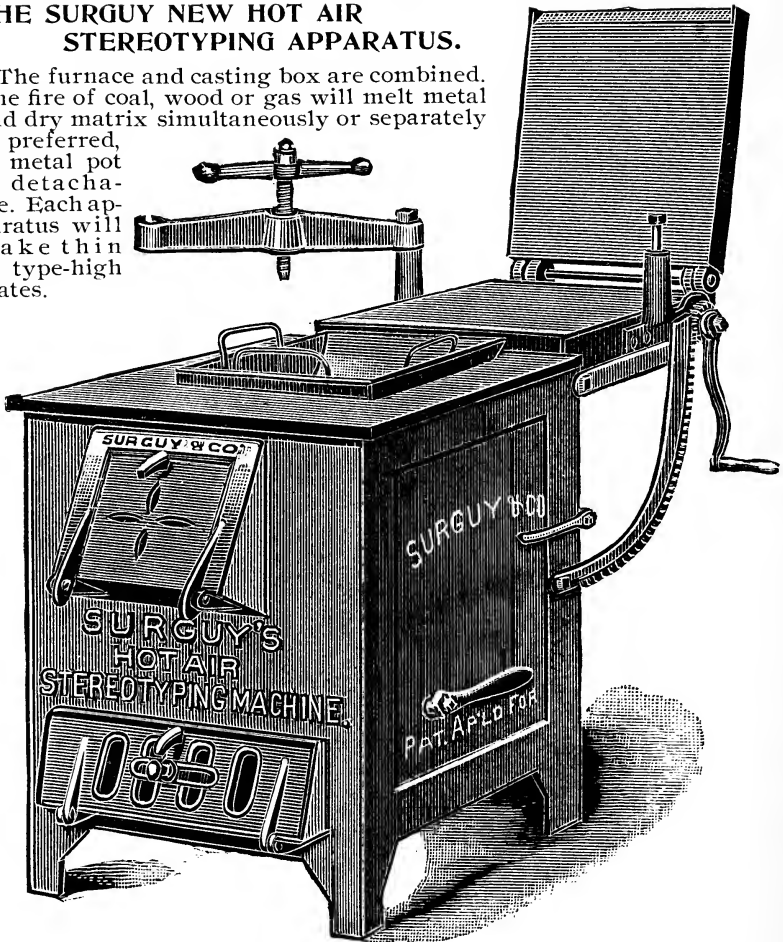

**Price of Apparatus and Outfit.**

	Size 8½x14 inches.	Size 12x20 inches.	Size 18x26 inches.
Combined furnace and casting box . . . . .	\$33.00	\$45.00	\$85.00
Iron bars, spacings and cores for type-high casts . . . . .	10.00	13.00	15.00
Iron shoot-board and plane . . . . .	9.00	12.00	15.00
Iron miter box and metal saw . . . . .	8.00	10.00	12.00
Beating brush . . . . .	3.00	3.00	3.00
Steel gauges for thin plates, small tools, blankets, brushes, prepared matrix paper, directions, etc. . . . .	7.00	7.00	10.00
Price, when ordered complete . . . . .	\$65.00	\$90.00	\$140.00

The 8½x14-inch apparatus will stereotype a form of 7½x10 inches. It is too small to use with wood or coal, and is fitted with a gasoline attachment, or gas may be used. The 12x20-inch apparatus will stereotype a form of 10x18 inches. The 18x26-inch apparatus will stereotype a form of 16x24 inches, taking in a standard six-column page of a newspaper.

**PREPARED MATRIX PAPER.**

Size, 12x19 inches, per dozen, by express . . . . .	\$ .50
Size, 19x24 inches, per dozen, by express . . . . .	1.00

**CROWN ENGRAVING PLATES.**

(PATENTED.)

Made by the Hoke Engraving Company.

A Crown Engraving Plate consists of a thin, dark, steel plate, covered with a soft, white composition. By means of special tools, used after the manner of pens, the drawing is made by cutting through the composition to the dark surface of the steel plate, which shows the drawing as it will appear when printed. No apprenticeship is needed. Anyone able to draw can do the work. Speed is gained by practice. Three or four tools and a scraping brass is all that is required for ordinary work. After the drawing is finished, a stereotype cast is made from it and the cut is ready for the press. The quickness and cheapness of the process are apparent. Any stereotype foundry can cast the plates, but for those who desire to do their own casting we have special simple and cheap stereotyping outfits suited to every line of work.

This process is suitable for rapid newspaper illustration. A cut may be got ready inside of thirty minutes.

This is also a good process for color work. The plate having been engraved and a cast taken, the composition is removed by washing until only a thin film remains; as many additional casts can now be taken as there are to be colors. The design appears upon the face of these casts, and it is an easy matter to cut away on each block the portion not wanted.

**Price List and Telegraph Code.**

The telegraphic code will be found convenient when plates are wanted in a hurry.

Size.	Net Price.	Tel. Code.
3 × 4 inches . . . . .	per dozen, \$ 4.50 . . . . .	—
3½ × 5 inches . . . . .	per dozen, 6.50 . . . . .	Breton.
4 × 6 inches . . . . .	per dozen, 9.00 . . . . .	Church.
5 × 6 inches . . . . .	per dozen, 11.00 . . . . .	Dore.
5 × 8 inches . . . . .	per dozen, 15.00 . . . . .	Errett.
6 × 10 inches . . . . .	per dozen, 21.60 . . . . .	Frost.
8 × 10 inches . . . . .	each, 2.50 . . . . .	Gaul.
10 × 12 inches . . . . .	each, 3.25 . . . . .	Hart.
10 × 18 inches . . . . .	each, 4.25 . . . . .	Inness.
12 × 16 inches . . . . .	each, 4.75 . . . . .	Johnson.
12 × 20 inches . . . . .	each, 5.75 . . . . .	Kelly.
16 × 16 inches . . . . .	each, 6.25 . . . . .	Leslie.
16 × 20 inches . . . . .	each, 7.75 . . . . .	Max.
18 × 20 inches . . . . .	each, 8.25 . . . . .	—

A credit of 15 per cent. allowed for used base plates returned in good order, freight prepaid.

**Appliances for Engraving on the Crown Engraving Plates.**

Hoke Engraving Tools, set of four, with scraping brass . . .	\$2.00 net.
Hoke Engraving Tools, each . . . . .	.50 net.
Tracing Needles, for transferring drawing upon the composition of plate, each . . . . .	.15 net.
Circle Former, for describing circles of all diameters, each . . .	.75 net.
Platograph, for tracing from drawing or print, reducing or enlarging the work . . . . .	12.50 net.

**Air Tools for Removing Dust from Plates.**

Bulb Blower, operated by hand . . . . .	1.00 net.
Foot Blower, operated by treadle, with stand and pump . . . . .	20.00 net.
Foot Blower, without stand . . . . .	15.00 net.

**PANELED BACKING FOR ELECTROTYPES.**

**The Only Backing That Will Not Warp Under Any Circumstances.**

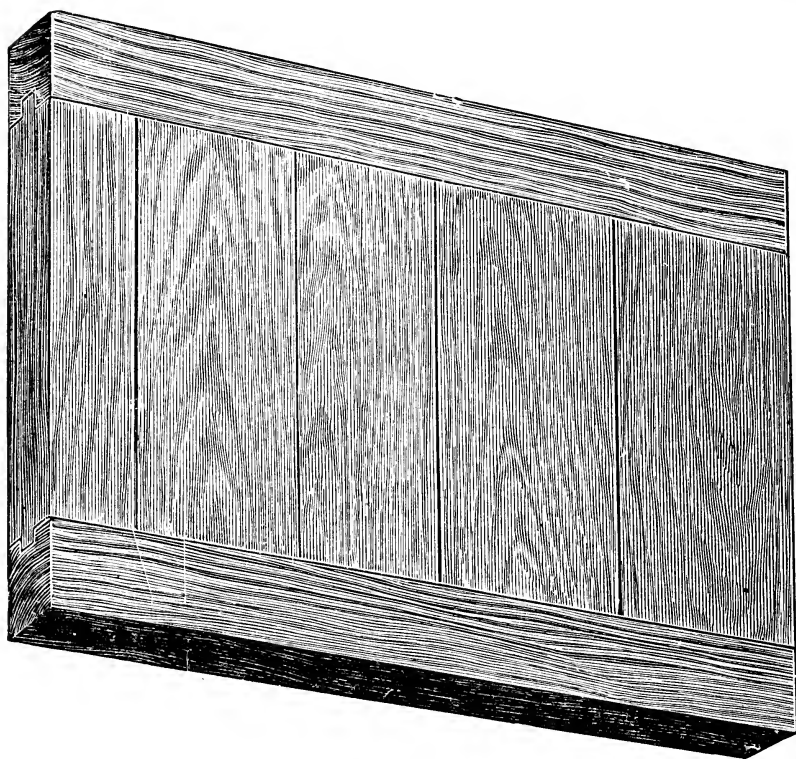

These paneled blocks are made in two-foot lengths, and put up in any width desired. They usually are ordered with half-inch variations. This is the only perfect backing for large cuts.

Price, per square foot . . . . . \$ .20

Special prices for large lots or regular supply. *Made to order only.*

**BACKING FOR ELECTROTYPES.**

Made from selected, well-seasoned stock, and kiln dried. This is supplied to any height desired, planed perfectly smooth and flat on both sides, uniform in thickness, and free from knots or waste. It is put up in boxes, each containing 100 feet, cut in 2 feet lengths, assorted widths,  $2\frac{5}{32}$ -inch high, for use without replaning, and  $\frac{7}{8}$ -inch high for replaning with Daniels Planer before use, but can be supplied to order to other thicknesses if required. The use of this backing results in saving of space, and absence of waste.

Birch, per square foot, in boxes of 100 feet . . . . . \$ .10





1

AMERICAN  
TYPE  
FOUNDERS CO.







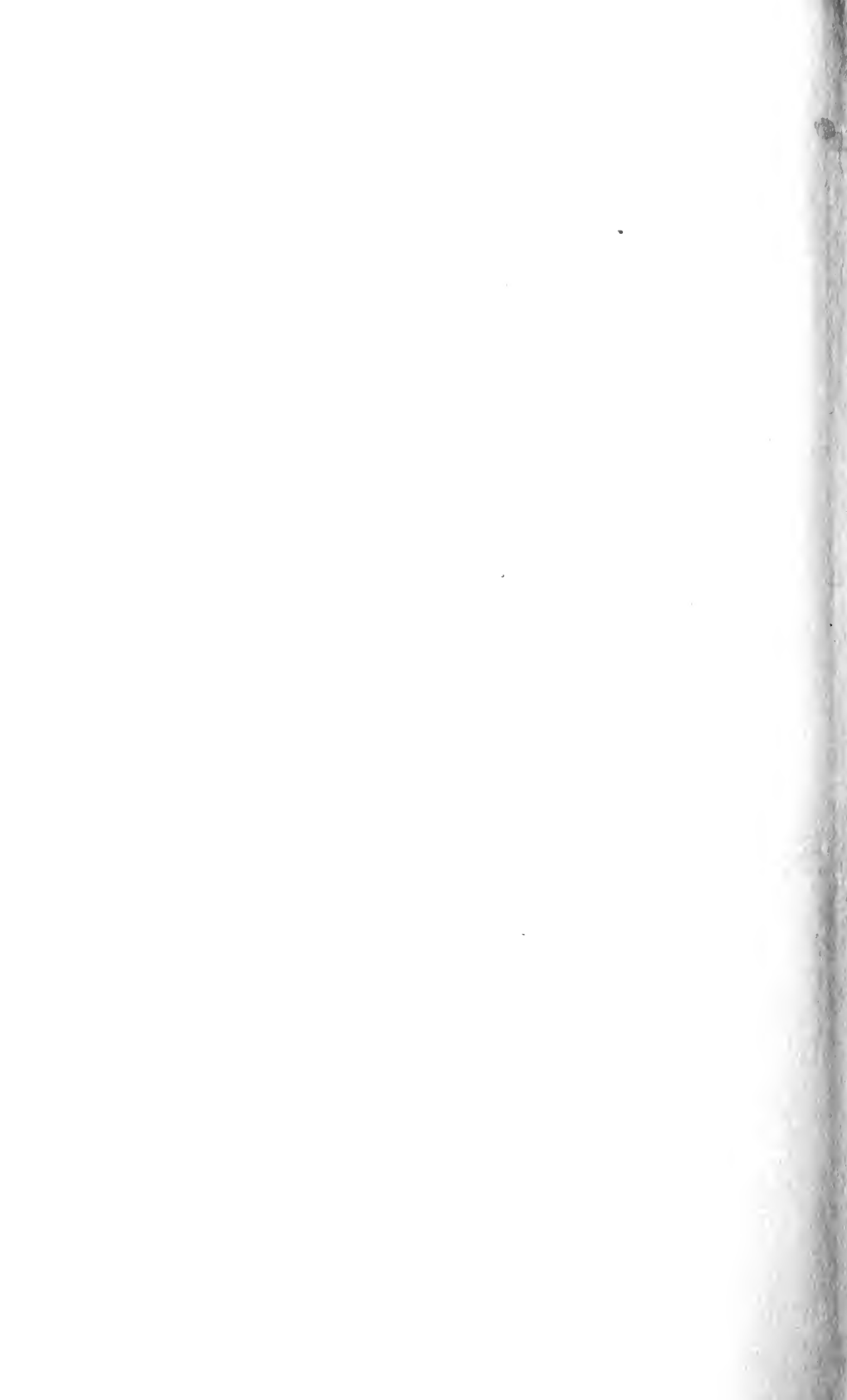









31197 12226 9993

**DATE DUE**

MAY 22 1991		NOV 18 2008
JUL 17 1991	MAR 28 1998	AUG 18 2009
JUL 23 1991	AUG 09 1996	
FEB 01 1992	APR 15 1997	
OCT 29 1993	JUN 08 1998	
FEB 22 1997	APR 21 1999	
JUL 19 1994	FEB 13 2002	
APR 08 1994	APR 13 2004	
DEC 23 1994	APR 13 2004	
DEC 16 1997	SEP 06 2007	
JUL 08 1995	AUG 18 2007	
MAR 1 1996	AUG 04 2008	

